

NV/NH

Low voltage NH knife-blade fuse-links	684
Fuse bases	694
Accessories	704
Low voltage fuse-rails	705
Strip type fuse-switch-disconnectors	709
NV/NH disconnectors with fuses	714
Technical data	723

*DC and PV NH fuses are in Special Purpose Fuses and Green Protect catalogues



LOW VOLTAGE NH KNIFE-BLADE FUSES



Low voltage NH knife-blade fuse-links

NV/NH KOMBI advantages

ETI is introducing a new generation of low-voltage fuse-links from size NV00C up to NV3 with new, dual indication of fuse-link operation, called KOMBI. The indicator is easily visible on the top and centre of the fuse-link, whether it is situated in a standard fuse base or vertical fuse rail or in fuse-switch disconnecter.

The most important advantages of NV/NH KOMBI fuse-links:

- High breaking capacity, 120 kA (400 V gG - except NV00C and NV00CI, and 500 V gG) and 100 kA (400 V gG NV00C and NV00CI, 690 V gG, 400 V gTR, 400 V gF and 690 V aM)
- Rated voltages: 400 V a.c., 500 V a.c., 690 V a.c.
- Two versions of covers: aluminium, when the removal tag is under voltage and plastic, when insulated metal removal tag is incorporated into the plastic cover
- VDE certificates and CCA/CB test reports

General about NV/NH fuse-links

Their dimensions correspond with DIN 43620, other technical characteristics correspond with the requirements of the following standards:

- Rated voltage 400V/500V/690V/gG: IEC 60269-1:2005 / EN 60269-1:1998+A1:2005 IEC 60269-2:1986+Corr.1:1996+A11995+A2:2001 / EN 60269-2:1995+A1:1998+A2:2002 IEC 60269-2-1:2004 / HD 60269-2-1:2005
- Rated voltage 690V/aM: VDE 0636-2011
- Rated voltage 400V/gF: PN-IEC 60269-2
- Rated voltage 400V/gTr: VDE 0636-2011

Short description of constituent parts for NV/NH fuse-links

The body of the fuse-link is made of quality steatite which is highly resistant against temperature overloads. In the inner part of the steatite body there is a copper melting element which is welded on a specially shaped inner part of the contact knife by spot welding. By careful shaping of this part we achieved that during assembly the melting element is placed exactly into the middle of the inner place. The remaining inside place of the ceramic body is filled up with precisely determined granulation and chemical structure quartz sand. All contact knives are additionally protected with a layer of silver or on special order of nickel. On the base of cyclic tests we have proved that the fusing characteristics are very stable and the tolerance on the current axis can be up to ± 10%.

Fuse-link NV/NH gG

Rated current **2-1600 A** Breaking capacity **120 kA / 100 kA** Rated voltage **400, 500, 690 V**



NV/NH 00C KOMBI gG

Rated current [A]	Code No.			Korrosionsfest ~ 400V 100 kA	Weight [g]	Packaging [pcs]
	~ 400V 100 kA	~ 500V 120 kA	~ 690V 100 kA			
2	004181101	004181201	004181301	004181118	125	3/120
4	004181102	004181202	004181302	004181119	125	3/120
6	004181103	004181203	004181303	004181120	125	3/120
10	004181104	004181204	004181304	004181121	125	3/120
16	004181105	004181205	004181305	004181122	125	3/120
20	004181106	004181206	004181306	004181123	125	3/120
25	004181107	004181207	004181307	004181138	125	3/120
32	004181108	004181208	004181308	004181139	125	3/120
35	004181109	004181209	004181309	004181140	125	3/120
40	004181110	004181210	004181310	004181141	125	3/120
50	004181111	004181211	004181311	004181142	125	3/120
63	004181112	004181212		004181143	125	3/120
80	004181113	004181213		004181130	125	3/120
100	004181114	004181214		004181131	125	3/120
125		004181215			125	3/120
160	004181216				125	3/120

Low voltage NH knife-blade fuse-links

NV/NH 00 CI KOMBI gG*

Rated current [A]	Code No.			Weight [g]	Packaging [pcs]
	~ 400V 100 kA	~ 500V 120 kA	~ 690V 100 kA		
2	004191101	004191201	004191301	125	3/120
4	004191102	004191202	004191302	125	3/120
6	004191103	004191203	004191303	125	3/120
10	004191104	004191204	004191304	125	3/120
16	004191105	004191205	004191305	125	3/120
20	004191106	004191206	004191306	125	3/120
25	004191107	004191207	004191307	125	3/120
32	004191108	004191208	004191308	125	3/120
35	004191109	004191209	004191309	125	3/120
40	004191110	004191210	004191310	125	3/120
50	004191111	004191211	004191311	125	3/120
63	004191112	004191212		125	3/120
80	004191113	004191213		125	3/120
100	004191114	004191214		125	3/120
125				125	3/120
160				125	3/120

* INSULATED

NV/NH 00 C gG with striker pin

Rated current [A]	Code No. ~ 690 V 100 kA	Weight [g]	Packaging [pcs]
2	004111172	135	3
4	004111173	135	3
6	004111174	135	3
10	004111175	135	3
16	004111176	135	3
20	004111177	135	3
25	004111178	135	3
32	004111179	135	3
35	004111180	135	3
40	004111181	135	3

NV/NH 00 KOMBI gG

Rated current [A]	Code No.			Korrosionsfest ~ 400V 120 kA	Weight [g]	Packaging [pcs]
	~ 400V 120 kA	~ 500V 120 kA	~ 690V 100 kA			
63			004182312		173	3/90
80			004182313		173	3/90
100			004182314		173	3/90
125	004182115	004182215	004182315	004182118	173	3/90
160	004182116	004182216		004182119	173	3/90

NV/NH 00 I KOMBI gG*

Rated current [A]	Code No.			Weight [g]	Packaging [pcs]
	~ 400V 120 kA	~ 500V 120 kA	~ 690V 100 kA		
63			004192312	173	3/90
80			004192313	173	3/90
100			004192314	173	3/90
125	004192115	004192215	004192315	173	3/90
160	004192116	004192216		173	3/90

* INSULATED





NV/NH 00 gG with striker pin

Rated current [A]	Code No.		Weight [g]	Packaging [pcs]
	~ 500 V 120 kA	~ 690 V 100 kA		
50		004111182	205	3
63		004111183	205	3
80		004111184	205	3
100		004111185	205	3
125		004111186	205	3
160	004111187			



NV/NH 0 KOMBI gG

Rated current [A]	Code No.		Weight [g]	Packaging [pcs]
	~ 500 V 120 kA	~ 690 V 100 kA		
6	004183203	004183303	226	3/45
10	004183204	004183304	226	3/45
16	004183205	004183305	226	3/45
20	004183206	004183306	226	3/45
25	004183207	004183307	226	3/45
32	004183208	004183308	226	3/45
35	004183209	004183309	226	3/45
40	004183210	004183310	226	3/45
50	004183211	004183311	226	3/45
63	004183212	004183312	226	3/45
80	004183213	004183313	226	3/45
100	004183214	004183314	226	3/45
125	004183215	004183315	226	3/45
160	004183216		226	3/45

NV/NH 1 C KOMBI gG

Rated current [A]	Code No.			Korrosionsfest ~ 400V 120 kA	Weight [g]	Packaging [pcs]
	~ 400V 120 kA	~ 500V 120 kA	~ 690V 100 kA			
25	004184107	004184207	004184307	004184131	233	3/45
32	004184108	004184208	004184308	004184130	233	3/45
35	004184109	004184209	004184309	004184129	233	3/45
40	004184110	004184210	004184310	004184128	233	3/45
50	004184111	004184211	004184311	004184127	233	3/45
63	004184112	004184212	004184312	004184138	233	3/45
80	004184113	004184213	004184313	004184139	233	3/45
100	004184114	004184214	004184314	004184132	233	3/45
125	004184115	004184215	004184315	004184133	233	3/45
160	004184116	004184216		004184134	233	3/45

Low voltage NH knife-blade fuse-links

NV/NH 1C I KOMBI gG*

Rated current [A]	Code No.			Weight [g]	Packaging [pcs]
	~ 400V 120 kA	~ 500V 120 kA	~ 690V 100 kA		
25	004194107	004194207	004194307	233	3/45
32	004194108	004194208	004194308	233	3/45
35	004194109	004194209	004194309	233	3/45
40	004194110	004194210	004194310	233	3/45
50	004194111	004194211	004194311	233	3/45
63	004194112	004194212	004194312	233	3/45
80	004194113	004194213	004194313	233	3/45
100	004194114	004194214	004194314	233	3/45
125	004194115	004194215	004194315	233	3/45
160	004194116	004194216		233	3/45

* INSULATED

NV/NH 1 KOMBI gG

Rated current [A]	Code No.			Korrosionsfest ~ 400V 120 kA	Weight [g]	Packaging [pcs]
	~ 400V 120 kA	~ 500V 120 kA	~ 690V 100 kA			
63	004184120	004184220	004184320		430	3/24
80	004184121	004184221	004184321		430	3/24
100	004184122	004184222	004184322		430	3/24
125	004184123	004184223	004184323		430	3/24
160	004184124	004184224	004184324		430	3/24
200	004184117	004184217	004184317	004184135	430	3/24
224	004184118	004184218	004184318	004184136	430	3/24
250	004184119	004184219	004184319	004184137	430	3/24

NV/NH 1 I KOMBI gG*

Rated current [A]	Code No.			Weight [g]	Packaging [pcs]
	~ 400V 120 kA	~ 500V 120 kA	~ 690V 100 kA		
63	004194120	004194220	004194320	430	3/24
80	004194121	004194221	004194321	430	3/24
100	004194122	004194222	004194322	430	3/24
125	004194123	004194223	004194323	430	3/24
160	004194124	004194224	004194324	430	3/24
200	004194117	004194217	004194317	430	3/24
224	004194118	004194218	004194318	430	3/24
250	004194119	004194219	004194319	430	3/24

* INSULATED





NV/NH 1 gG with striker pin

Rated current [A]	Code No. ~ 690 V 100 kA	Weight [g]	Packaging [pcs]
63	004113340	452	3
80	004113341	452	3
100	004113342	452	3
125	004113343	452	3
160	004113344	452	3
200	004113345	452	3
224	004113346	452	3
250	004113347	452	3

NV/NH 2 C KOMBI gG

Rated current [A]	Code No.			Korrosionsfest ~ 400V 120 kA	Weight [g]	Packaging [pcs]
	~ 400V 120 kA	~ 500V 120 kA	~ 690V 100 kA			
63	004185112	004185212	004185312	004185144	430	3/15
80	004185113	004185213	004185313	004185145	430	3/15
100	004185114	004185214	004185314	004185146	430	3/15
125	004185115	004185215	004185315	004185147	430	3/15
160	004185116	004185216	004185316	004185133	430	3/15
200	004185117	004185217	004185317	004185134	430	3/15
224	004185118	004185218	004185318	004185135	430	3/15
250	004185119	004185219	004185319	004185136	430	3/15

NH/NH



NV/NH 2 CI KOMBI gG*

Rated current [A]	Code No.			Weight [g]	Packaging [pcs]
	~ 400V 120 kA	~ 500V 120 kA	~ 690V 100 kA		
63	004195112	004195212	004195312	430	3/15
80	004195113	004195213	004195313	430	3/15
100	004195114	004195214	004195314	430	3/15
125	004195115	004195215	004195315	430	3/15
160	004195116	004195216	004195316	430	3/15
200	004195117	004195217	004195317	430	3/15
224	004195118	004195218	004195318	430	3/15
250	004195119	004195219	004195319	430	3/15

* INSULATED

Low voltage NH knife-blade fuse-links

NV/NH 2 KOMBI gG

Rated current [A]	Code No.			Korrosionsfest ~ 400V 120 kA	Weight [g]	Packaging [pcs]
	~ 400V 120 kA	~ 500V 120 kA	~ 690V 100 kA			
280	004185120	004185220	004185320	004185137	500	3/15
300	004185121	004185221	004185321	004185138	500	3/15
315	004185122	004185222	004185322	004185139	500	3/15
355	004185123	004185223		004185140	500	3/15
400	004185124	004185224		004185141	500	3/15

NV/NH 2 I KOMBI gG*

Rated current [A]	Code No.			Weight [g]	Packaging [pcs]
	~ 400V 120 kA	~ 500V 120 kA	~ 690V 100 kA		
280	004195120	004195220	004195320	500	3/15
300	004195121	004195221	004195321	500	3/15
315	004195122	004195222	004195322	500	3/15
355	004195123	004195223		500	3/15
400	004195124	004195224		500	3/15

* INSULATED

NV/NH 2 gG with striker pin

Rated current [A]	Code No.	Weight [g]	Packaging [pcs]
	~ 690 V 100 kA		
160	004114345	593	3
200	004114346	593	3
224	004114347	593	3
250	004114348	593	3
300	004114349	593	3
315	004114350	593	3

NV/NH 3 C KOMBI gG

Rated current [A]	Code No.			Korrosionsfest ~ 400V 120 kA	Weight [g]	Packaging [pcs]
	~ 400V 120 kA	~ 500V 120 kA	~ 690V 100 kA			
250	004186119	004186219	004186319	004186150	510	3/12
280	004186120	004186220	004186320		510	3/12
300	004186121	004186221	004186321	004186140	510	3/12
315	004186122	004186222	004186322	004186141	510	3/12
355	004186123	004186223		004186142	510	3/12
400	004186124	004186224		004186143	510	3/12





NV/NH 3 KOMBI gG

Rated current [A]	Code No.			Korrosionsfest ~ 400V 120 kA	Weight [g]	Packaging [pcs]
	~ 400V 120 kA	~ 500V 120 kA	~ 690V 100 kA			
355			004186328		923	3/12
400			004186329		923	3/12
425	004186130	004186230	004186330	004186144	923	3/12
500	004186131	004186231	004186331	004186145	923	3/12
560	004186132	004186232			923	3/12
630	004186133	004186233		004186147	923	3/12

NV/NH 3 I KOMBI gG*

Rated current [A]	Code No.			Weight [g]	Packaging [pcs]
	~ 400V 120 kA	~ 500V 120 kA	~ 690V 100 kA		
200	004196123	004196223	004196323	923	3/12
224	004196124	004196224	004196324	923	3/12
250	004196125	004196225	004196325	923	3/12
300	004196126	004196226	004196326	923	3/12
315	004196127	004196227	004196327	923	3/12
355	004196128	004196228	004196328	923	3/12
400	004196129	004196229	004196329	923	3/12
425	004196130	004196230	004196330	923	3/12
500	004196131	004196231	004196331	923	3/12
560	004196132	004196232		923	3/12
630	004196133	004196233		923	3/12

* INSULATED



NV/NH 3 gG with striker pin

Rated current [A]	Code No. ~ 690 V 100 kA	Weight [g]	Packaging [pcs]
300	004115121	895	3
315	004115122	895	3
400	004115123	895	3
425	004115124	895	3
500	004115125	895	3

NV/NH 4 gG

Rated current [A]	Code No. ~ 500 V 120 kA	Weight [g]	Packaging [pcs]
710	004116102	2130	1/12
800	004116103	2130	1/12
900	004116105	2130	1/12
1000	004116104	2130	1/12
1250	004116106	2130	1/12



Low voltage NH knife-blade fuse-links

NV/NH 4a gG

Rated current [A]	Code No.			Weight [g]	Packaging [pcs]
	~ 500 V, 120 kA	SI	~ 690 V 100 kA		
630	004116108	004176026	004176105	2170	1/12
710	004116109	004176027	004176106	2170	1/12
800	004116110	004176028	004176107	2170	1/12
900	004116111	004176029	004176108	2170	1/12
1000	004116112	004176030	004176109	2170	1/12
1250	004116113	004176031	004176110	2170	1/12
1500	004116119	004176032		2170	1/12
1600	004116120	004176033		2170	1/12

NV/NH 4a gG with striker pin

Rated current [A]	Code No. ~ 690 V 100 kA	Weight [g]	Packaging [pcs]
500	004116186	2835	1
630	004116187	2835	1
800	004116188	2835	1
1000	004116189	2835	1
1250	004116190	2835	1



Fuse-link NV/NH aM

Rated current 2-1250 A	Breaking capacity 100 kA / 120 kA	Rated voltage 500V, 690 V
----------------------------------	---	-------------------------------------

Fuse-links with aM characteristics are intended for protection of switchgears and controlgears as well as motors in motor drives where gG characteristics do not comply with all requirements of successful protection of these devices. They are made in all standard NV sizes from 00 to 4a for all standard rated currents and for voltages to 690 V. Their main duty is to enable a full usage of switchgears and controlgears in the region of starting currents and to prevent sparking or destruction of protective contacts in case of short-circuit currents. It should be noted that these fuse-links are intended only for protection in the limited region (in the region of short-circuit currents).



NV/NH fuse-link aM

Rated current [A]	Code No. ~ 690 V, 100 kA							
	NV 00 C kombi	NV 00 kombi	NV 0	NV 1 kombi	NV 2 C kombi	NV 2 kombi	NV3 kombi	NV4a
2	004181401							
4	004181402							
6	004181403							
10	004181404			004184425				
16	004181405		004112125**	004184426				
20	004181406		004112126**	004184427				
25	004181407		004112127**	004184428				
32	004181408		004112128**					
35	004181409		004112129**	004184429	004185429			
40	004181410		004112130**	004184430	004185430			
50	004181411	004182411	004112131**	004184431	004185431			
63	004181412	004182412	004112132**	004184420	004185412			
80	004181413*	004182413	004112133**	004184421	004185413			
100	004181414*	004182414	004112134**	004184422	004185414			
125		004111735**	004112135**	004184423	004185415			
160		004111736**	004112136**	004184424	004185416	004185425		
200				004184417	004185417	004185426		
224				004184418	004185418	004185427		
250				004184419	004185419	004185428		
280						004185420		
300						004185421		
315						004185422		
355						004185423	004186428	
400						004185424	004186429	
425							004186430	
500							004186431	
630							004186432**	004187432**
710								004187433**
800								004187434**
900								004187435**
1000								004187436**
1250								004187437**

Weight and Packaging the same as for gG fuse-links.

*500V, 120 kA

** NOT in KOMBI version

Low voltage NH knife-blade fuse-links

Fuse-link NV/NH gF

Rated current **20-250 A** Breaking capacity **100 kA** Rated voltage **400 V**

Fuse-links with gF current characteristics are intended for protection of low voltage installations and energy lines, where expected short circuit currents are low. We offer all standard rated currents in sizes NV00C, NV00, NV1C and NV1 for voltages of up to 400V.

NV/NH fuse-link gF

Rated current [A]	Code No. ~ 400 V				Weight [g]	Packaging [pcs]
	NV/NH 00 C	NV/NH 00	NV/NH 1 C	NV/NH 1		
20	004119200		004139200		the same as for gG fuse-links	the same as for gG fuse-links
25	004119201		004139201			
32	004119202		004139202			
40	004119203		004139203			
50	004119204		004139204			
63		004119100	004139205			
80		004119101	004139206			
100		004119102	004139207			
125		004119103	004139208			
160		004119104	004139209			
200				004139100		
250				004139101		



Fuse-link NV/NH gTr

Rated transformer power **50-1000 kVA** Breaking capacity **100 kA** Rated voltage **400 V**

NV/NH fuse-link gTr

Rated transformer power [kVA]	Code No.						Weight [g]	Packaging [pcs]
	NV/NH 2	NV/NH 2 INSULATED	NV/NH 3c	NV/NH 3	NV/NH 3 INSULATED	NV/NH 4a		
50	004114400*	004114407*	004115400*		004115430*	004116400	the same as for gG fuse-links	the same as for gG fuse-links
75	004114401*	004114413*	004115401*		004115431*	004116401		
100	004114402*	004114412*	004115402*		004115432*	004116402		
125	004114403*	004114408*	004115403*		004115433*	004116403		
160	004114404*	004114409*	004115404*		004115434*	004116404		
200	004114405*	004114410*	004115405*		004115435*	004116405		
250	004114406*	004114411*	004115406*		004115436*	004116406		
315				004115407*	004115437*	004116407		
400				004115408*	004115438*	004116408		
500				004115409		004116409		
630				004115410		004116410		
800						004116411		
1000						004116412		

* KOMBI version



Fuse bases

Advantages

PK fuse bases with ceramic insulation for NH fuses are suitable for surface mounting on mounting plates and can be used in combination with NH fuse-links according to DIN VDE 0636-2/IEC 60269-2 as well as solid links.

They offer a compact and simple solution for application of fuses as protective elements in low voltage distribution boards and are characterized by silver plated contacts, in-house developed technical ceramic materials with high thermal resistance and a broad range of connections.

PK fuse bases are available in sizes 00 to 3, in 1-pole and 3-pole version. The range comes with accessories including protection barriers, IP20 finger safe protection kits and neutral links, which, along with the possibility of attaching additional poles, provides an optimal solution for every application.

Rated for fuse-links with breaking capacity up to 200 kA.

Ratings:
Rated voltage: 690 V a.c.
Rated currents: 160 A - 630 A

Standards:
IEC 60269-2
DIN VDE 0636-2
DIN 43620

As one of the leading producers of technical ceramics for fuse applications we have developed a range of extremely reliable thermosetting materials with high thermal resistance, dimensional stability and superior resistance to tracking.

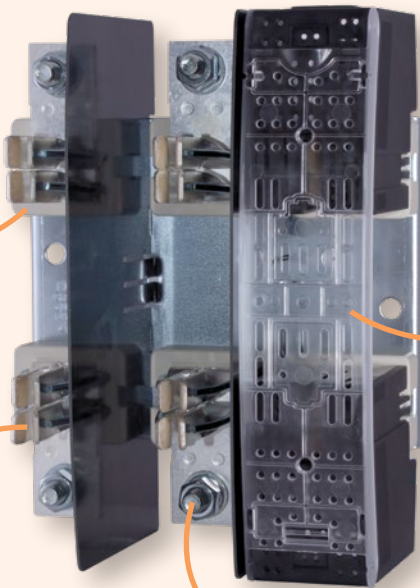

Sturdy and compact IP 20 protection kits.

Galvanically silver plated contacts, providing ideal contact characteristics.

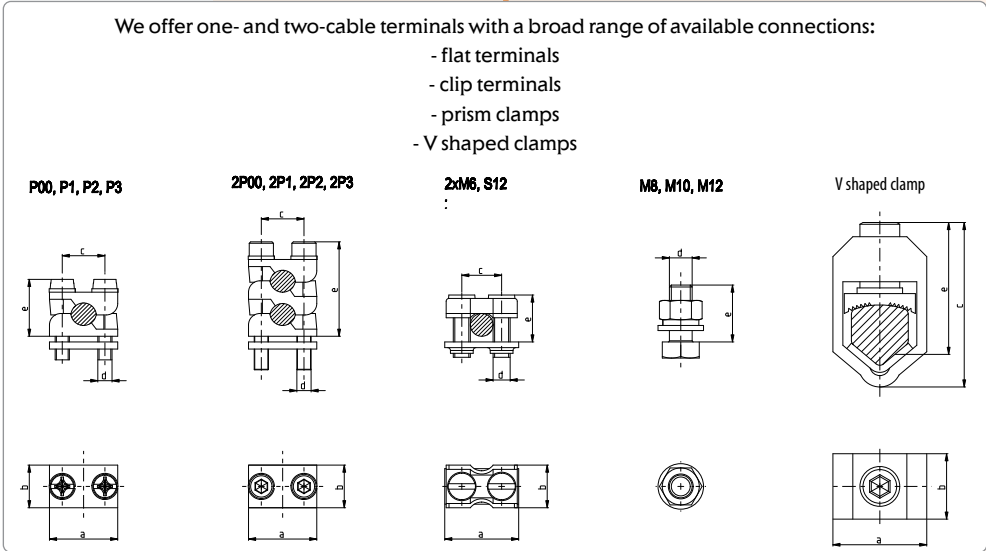

Fuse bases

PK Fuse Bases with Ceramic Insulation sizes 00 to 3

Rated voltage
690 V

1-pole fuse base size 00

Type	I _n [A]	Code No.	Weight [g/pc]	Packaging [pcs]
PK 00 M8-M8 1p S	160	004123000	173	3
PK 00 2M6-2M6 1p S	160	004123001	173	3
PK 00 M8-2M6 1p S	160	004123002	173	3
PK 00 M8-P00 1p S	160	004123003	190	3
PK 00 M8-2P00 1p S	160	004123004	205	3
PK 00 P00-P00 1p S	160	004123005	205	3
PK 00 P00-2P00 1p S	160	004123006	219	3
PK 00 2P00-2P00 1p S	160	004123007	233	3
PKI 00 M8-M8 1p S	160	004123011	213	3
PKI 00 2M6-2M6 1p S	160	004123012	213	3
PKI 00 M8-2M6 1p S	160	004123013	213	3
PKI 00 M8-P00 1p S	160	004123014	230	3
PKI 00 M8-2P00 1p S	160	004123015	245	3
PKI 00 P00-P00 1p S	160	004123016	245	3
PKI 00 P00-2P00 1p S	160	004123017	259	3
PKI 00 2P00-2P00 1p S	160	004123018	273	3
PKIP 00 M8-M8 1p S	160	004123021	223	3
PKIP 00 2M6-2M6 1p S	160	004123022	223	3
PKIP 00 M8-2M6 1p S	160	004123023	223	3
PKIP 00 M8-P00 1p S	160	004123024	240	3
PKIP 00 M8-2P00 1p S	160	004123025	255	3
PKIP 00 P00-P00 1p S	160	004123026	255	3
PKIP 00 P00-2P00 1p S	160	004123027	269	3
PKIP 00 2P00-2P00 1p S	160	004123028	283	3

PK basic version

PKI fuse base with terminal covers

PKIP fuse base with terminal covers and fuse cover

3-pole fuse base size 00

Type	I _n [A]	Code No.	Weight [g/pc]	Packaging [pcs]
PK 00 M8-M8 3p S	160	004132100	558	1
PK 00 2M6-2M6 3p S	160	004132101	563	1
PK 00 M8-2M6 3p S	160	004132102	560	1
PK 00 M8-P00 3p S	160	004132103	608	1
PK 00 M8-2P00 3p S	160	004132104	651	1
PK 00 P00-P00 3p S	160	004132105	658	1
PK 00 P00-2P00 3p S	160	004132106	700	1
PK 00 2P00-2P00 3p S	160	004132107	743	1
PKI 00 M8-M8 3p S	160	004132111	675	1
PKI 00 2M6-2M6 3p S	160	004132112	680	1
PKI 00 M8-2M6 3p S	160	004132113	677	1
PKI 00 M8-P00 3p S	160	004132114	725	1
PKI 00 M8-2P00 3p S	160	004132115	768	1
PKI 00 P00-P00 3p S	160	004132116	775	1
PKI 00 P00-2P00 3p S	160	004132117	817	1
PKI 00 2P00-2P00 3p S	160	004132118	860	1
PKIP 00 M8-M8 3p S	160	004132121	704	1
PKIP 00 2M6-2M6 3p S	160	004132122	709	1
PKIP 00 M8-2M6 3p S	160	004132123	706	1
PKIP 00 M8-P00 3p S	160	004132124	754	1
PKIP 00 M8-2P00 3p S	160	004132125	797	1
PKIP 00 P00-P00 3p S	160	004132126	804	1
PKIP 00 P00-2P00 3p S	160	004132127	846	1
PKIP 00 2P00-2P00 3p S	160	004132128	889	1

PK basic version with protective barriers

PKI fuse base with terminal covers

PKIP fuse base with terminal covers and fuse covers





*Terminal covers and fuse covers sold separately

1-pole fuse base PK 1, 2, 3

Tipus	I _n [A]	Code No.	Weight [g/pc]	Packaging [pcs]
PK 1 M10-M10 1p S	250	004123100	603	3
PK 1 M10-S12 1p S	250	004123101	595	3
PK 1 S12-S12 1p S	250	004123102	587	3
PK 1 M10-P1 1p S	250	004123103	665	3
PK 1 M10-2P1 1p S	250	004123104	715	3
PK 1 P1-P1 1p S	250	004123105	727	3
PK 1 P1-2P1 1p S	250	004123106	777	3
PK 1 2P1-2P1 1p S	250	004123107	827	3
PK 2 M10-M10 1p S	400	004123200	840	3
PK 2 M10-S12 1p S	400	004123201	833	3
PK 2 S12-S12 1p S	400	004123202	825	3
PK 2 M10-P2 1p S	400	004123203	963	3
PK 2 M10-2P2 1p S	400	004123204	1029	3
PK 2 P2-P2 1p S	400	004123205	1085	3
PK 2 P2-2P2 1p S	400	004123206	1151	3
PK 2 2P2-2P2 1p S	400	004123207	1217	3
PK 3 M12-M12 1p S	630	004123300	1106	3
PK 3 M12-P3 1p S	630	004123301	1265	3
PK 3 M12-2P3 1p S	630	004123302	1360	3
PK 3 P3-P3 1p S	630	004123303	1424	3
PK 3 P3-2P3 1p S	630	004123304	1519	3
PK 3 2P3-2P3 1p S	630	004123305	1614	3

NV/NH



*Terminal covers and fuse covers sold separately

3-pole fuse base PK 1, 2, 3

Type	I _n [A]	Code No.	Weight [g/pc]	Packaging [pcs]
PK 1 M10-M10 3p S	250	004132200	1809	1
PK 1 M10-S12 3p S	250	004132201	1785	1
PK 1 S12-S12 3p S	250	004132202	1761	1
PK 1 M10-P1 3p S	250	004132203	1995	1
PK 1 M10-2P1 3p S	250	004132204	2145	1
PK 1 P1-P1 3p S	250	004132205	2181	1
PK 1 P1-2P1 3p S	250	004132206	2331	1
PK 1 2P1-2P1 3p S	250	004132207	2481	1
PK 2 M10-M10 3p S	400	004132300	2520	1
PK 2 M10-S12 3p S	400	004132301	2499	1
PK 2 S12-S12 3p S	400	004132302	2475	1
PK 2 M10-P2 3p S	400	004132303	2889	1
PK 2 M10-2P2 3p S	400	004132304	3087	1
PK 2 P2-P2 3p S	400	004132305	3255	1
PK 2 P2-2P2 3p S	400	004132306	3453	1
PK 2 2P2-2P2 3p S	400	004132307	3651	1
PK 3 M12-M12 3p S	630	004132400	3318	1
PK 3 M12-P3 3p S	630	004132401	3795	1
PK 3 M12-2P3 3p S	630	004132402	4080	1
PK 3 P3-P3 3p S	630	004132403	4272	1
PK 3 P3-2P3 3p S	630	004132404	4557	1
PK 3 2P3-2P3 3p S	630	004132405	4824	1

PK basic version with protective barriers

Fuse bases

Accessories

Type	Code No.	Weight [g/pc]	Packaging [pcs]
Terminal covers			
ZP PT 00-1	004129010	20	6
ZP PT 1-1	004129012	47,5	6
ZP PT 2-1	004129013	62	6
ZP PT 3-1	004129014	73,5	6
Fuse covers			
PZP PT 00-1	004129020	9,5	6
PZP PT 1-1	004129022	25	6
PZP PT 2-1	004129023	36,5	6
PZP PT 3-1	004129024	45	6
Protective barriers			
PR PK0 S	004941320	17	20
PR PK1 S	004941321	47	20
PR PK2 S	004941322	56	20
PR PK3 S	004941323	62	20

Neutral terminal base / Earth clamp

Type	I_n [A]	Code No.	Weight [g/pc]	Packaging [pcs]
PK 0/0 M8-2M5 S	160	004941410	187	3
PK 1/0 M10-M10 S	250	004941411	635	3
PK 2/0 M10-M10 S	400	004941412	1016	3
PK 3/0 M12-M12 S	630	004941413	1066	3

1-pole fuse base PK 0, 4

Type	I_n [A]	Code No.	Weight [g]	Packaging [pcs]
PK 0 M8 - 2 x M6	160	004122009	258	3/90
PK 0 M8 - M8	160	004122002	258	3/90
PK 02 x M6 - 2 x M6	160	004122008	258	3/90
PK 4	1250	004122006	3030	1/7

3-pole fuse base PK 0

Type	I_n [A]	Code No.	Weight [g]	Packaging [pcs]
PK 0/3 M8 - 2 x M6	160	004132007	650	1/18
PK 0/3 M8 - M8	160	004132002	650	1/18
PK 0/3 2xM6 - 2xM6	160	004132016	650	1/18



Plastic fuse bases type PT size 00 to 3

Rated voltage
690 V

Advantages

Plastic fuse bases PT for NH fuses are suitable for screw mounting / surface mounting on mounting plates or mounting on DIN-rails, and can be used in combination with NH fuse-links according to DIN VDE 0636-2 / IEC 60269-2 as well as solid links.

They offer a compact and simple solution for application of fuses as protective elements in low voltage distribution boards and are characterized by silver plated contacts and a broad range of connections.

PT fuse bases are available in sizes 00 to 3, in 1-pole and 3-pole version. The range comes with accessories including protection barriers, IP20 finger safe protection kits and neutral links, which, along with the possibility of attaching additional poles, provides an optimal solution for every application.

Rated for fuse-links with breaking capacity up to 120 kA.

Ratings:
Rated voltage: 690 V a.c.
Rated current: 160 A - 630 A

Standards:
IEC 60269-2
DIN VDE 0636-21 & 201
DIN 43620

Possibility of linking more than 3 poles together using dividing partitions.

Possibility of screw mounting or mounting on DIN-rail.

Galvanically silver plated contacts, providing ideal contact characteristics.

Sturdy and compact IP 20 protection kits.

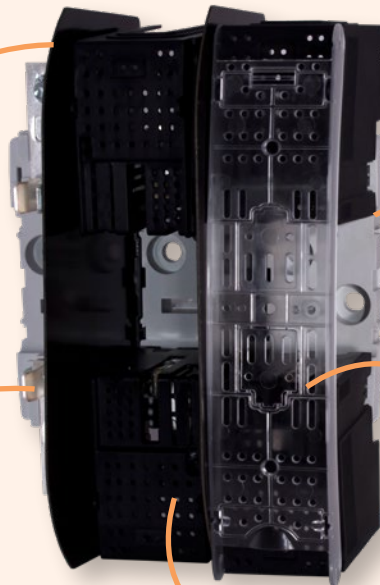

We offer one- and two-cable terminals with a broad range of available connections:

- flat terminals
- clip terminals
- prism clamps
- V shaped clamps

P00, P1, P2, P3

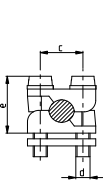

2P00, 2P1, 2P2, 2P3

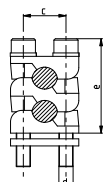

2xM6, S12

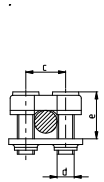

M8, M10, M12

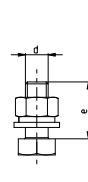

V shaped clamp

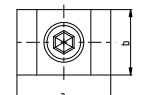
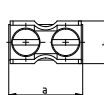
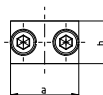
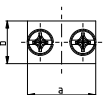
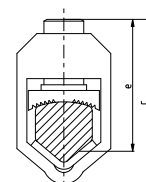

Fuse bases

1-pole fuse base size 00

Type	I _n [A]	Code No.	Weight [g/pc]	Packaging [pcs]
PT 00 M8-M8 1p	160	004121300	110	3
PT 00 2M6-2M6 1p	160	004121301	114	3
PT 00 M8-2M6 1p	160	004121302	112	3
PT 00 M8-P00 1p	160	004121303	126	3
PT 00 M8-2P00 1p	160	004121304	140	3
PT 00 P00-P00 1p	160	004121305	143	3
PT 00 P00-2P00 1p	160	004121306	157	3
PT 00 2P00-2P00 1p	160	004121307	172	3
<hr/>				
PTI 00 M8-M8 1p	160	004121311	150	3
PTI 00 2M6-2M6 1p	160	004121312	154	3
PTI 00 M8-2M6 1p	160	004121313	152	3
PTI 00 M8-P00 1p	160	004121314	166	3
PTI 00 M8-2P00 1p	160	004121315	180	3
PTI 00 P00-P00 1p	160	004121316	183	3
PTI 00 P00-2P00 1p	160	004121317	197	3
PTI 00 2P00-2P00 1p	160	004121318	212	3
<hr/>				
PTIP 00 M8-M8 1p	160	004121321	160	3
PTIP 00 2M6-2M6 1p	160	004121322	164	3
PTIP 00 M8-2M6 1p	160	004121323	162	3
PTIP 00 M8-P00 1p	160	004121324	176	3
PTIP 00 M8-2P00 1p	160	004121325	190	3
PTIP 00 P00-P00 1p	160	004121326	193	3
PTIP 00 P00-2P00 1p	160	004121327	207	3
PTIP 00 2P00-2P00 1p	160	004121328	222	3

PT basic version

PTI fuse base with terminal covers

PTIP fuse base with terminal covers and fuse cover

3-pole fuse base size 00

Type	I _n [A]	Code No.	Weight [g/pc]	Packaging [pcs]
PT 00 M8-M8 3p	160	004131200	360	1
PT 00 2M6-2M6 3p	160	004131201	374	1
PT 00 M8-2M6 3p	160	004131202	367	1
PT 00 M8-P00 3p	160	004131203	410	1
PT 00 M8-2P00 3p	160	004131204	453	1
PT 00 P00-P00 3p	160	004131205	460	1
PT 00 P00-2P00 3p	160	004131206	502	1
PT 00 2P00-2P00 3p	160	004131207	545	1
<hr/>				
PTI 00 M8-M8 3p	160	004131211	425	1
PTI 00 2M6-2M6 3p	160	004131212	438	1
PTI 00 M8-2M6 3p	160	004131213	431	1
PTI 00 M8-P00 3p	160	004131214	475	1
PTI 00 M8-2P00 3p	160	004131215	518	1
PTI 00 P00-P00 3p	160	004131216	525	1
PTI 00 P00-2P00 3p	160	004131217	567	1
PTI 00 2P00-2P00 3p	160	004131218	610	1
<hr/>				
PTIP 00 M8-M8 3p	160	004131221	450	1
PTIP 00 2M6-2M6 3p	160	004131222	463	1
PTIP 00 M8-2M6 3p	160	004131223	456	1
PTIP 00 M8-P00 3p	160	004131224	500	1
PTIP 00 M8-2P00 3p	160	004131225	543	1
PTIP 00 P00-P00 3p	160	004131226	550	1
PTIP 00 P00-2P00 3p	160	004131227	592	1
PTIP 00 2P00-2P00 3p	160	004131228	635	1

PT basic version

PTI fuse base with terminal covers

PTIP fuse base with terminal covers and fuse cover

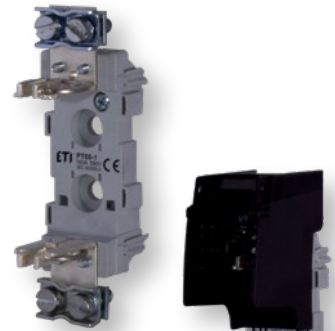

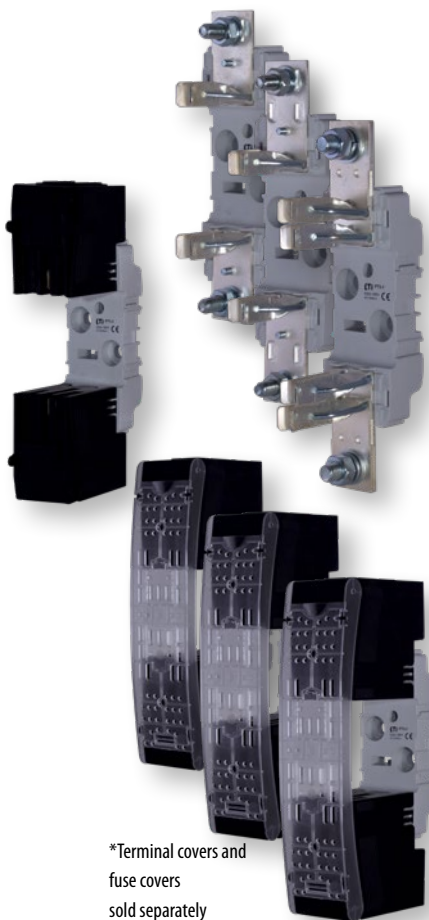

*Terminal covers and fuse covers sold separately

1-pole fuse base PT 1, 2, 3

Type	I _n [A]	Code No.	Weight [g/pc]	Packaging [pcs]
PT 1 M10-M10 1p	250	004121400	364	3
PT 1 M10-S12 1p	250	004121401	357	3
PT 1 S12-S12 1p	250	004121402	349	3
PT 1 M10-P1 1p	250	004121403	427	3
PT 1 M10-2P1 1p	250	004121404	477	3
PT 1 P1-P1 1p	250	004121405	489	3
PT 1 P1-2P1 1p	250	004121406	539	3
PT 1 2P1-2P1 1p	250	004121407	589	3
<hr/>				
PT 2 M10-M10 1p	400	004121500	394	3
PT 2 M10-S12 1p	400	004121501	387	3
PT 2 S12-S12 1p	400	004121502	379	3
PT 2 M10-P2 1p	400	004121503	517	3
PT 2 M10-2P2 1p	400	004121504	583	3
PT 2 P2-P2 1p	400	004121505	639	3
PT 2 P2-2P2 1p	400	004121506	705	3
PT 2 2P2-2P2 1p	400	004121507	771	3
<hr/>				
PT 3 M12-M12 1p	630	004121600	649	3
PT 3 M12-P3 1p	630	004121601	810	3
PT 3 M12-2P3 1p	630	004121602	905	3
PT 3 P3-P3 1p	630	004121603	966	3
PT 3 P3-2P3 1p	630	004121604	1061	3
PT 3 2P3-2P3 1p	630	004121605	1156	3

3-pole fuse base PT 1, 2, 3

Type	I _n [A]	Code No.	Weight [g/pc]	Packaging [pcs]
PT 1 M10-M10 3p	250	004131300	1204	1
PT 1 M10-S12 3p	250	004131301	1183	1
PT 1 S12-S12 3p	250	004131302	1159	1
PT 1 M10-P1 3p	250	004131303	1393	1
PT 1 M10-2P1 3p	250	004131304	1543	1
PT 1 P1-P1 3p	250	004131305	1579	1
PT 1 P1-2P1 3p	250	004131306	1729	1
PT 1 2P1-2P1 3p	250	004131307	1879	1
<hr/>				
PT 2 M10-M10 3p	400	004131400	1312	1
PT 2 M10-S12 3p	400	004131401	1291	1
PT 2 S12-S12 3p	400	004131402	1267	1
PT 2 M10-P2 3p	400	004131403	1681	1
PT 2 M10-2P2 3p	400	004131404	1879	1
PT 2 P2-P2 3p	400	004131405	2047	1
PT 2 P2-2P2 3p	400	004131406	2245	1
PT 2 2P2-2P2 3p	400	004131407	2443	1
<hr/>				
PT 3 M12-M12 3p	630	004131500	2105	1
PT 3 M12-P3 3p	630	004131501	2588	1
PT 3 M12-2P3 3p	630	004131502	2873	1
PT 3 P3-P3 3p	630	004131503	3056	1
PT 3 P3-2P3 3p	630	004131504	3341	1
PT 3 2P3-2P3 3p	630	004131505	3626	1

PT basic version with protective barriers



*Terminal covers and fuse covers sold separately

Fuse bases

Accessories

Type	Code No.	Weight [g/pc]	Packaging [pcs]
Terminal covers			
ZP PT 00-1	004129010	20	6
ZP PT 00-3	004129011	56,7	1
ZP PT 1-1	004129012	47,5	6
ZP PT 2-1	004129013	62	6
ZP PT 3-1	004129014	73,5	6
Fuse covers			
PZP PT 00-1	004129020	9,5	6
PZP PT 00-3	004129021	14,7	6
PZP PT 1-1	004129022	25	6
PZP PT 2-1	004129023	36,5	6
PZP PT 3-1	004129024	45	6
Protective barriers			
PR PT00-1	004941330	18,1	20
PR PT00-3	004941331	17,5	20
PR PT1	004941332	38	20
PR PT2	004941333	45,7	20
PR PT3	004941334	52,4	20

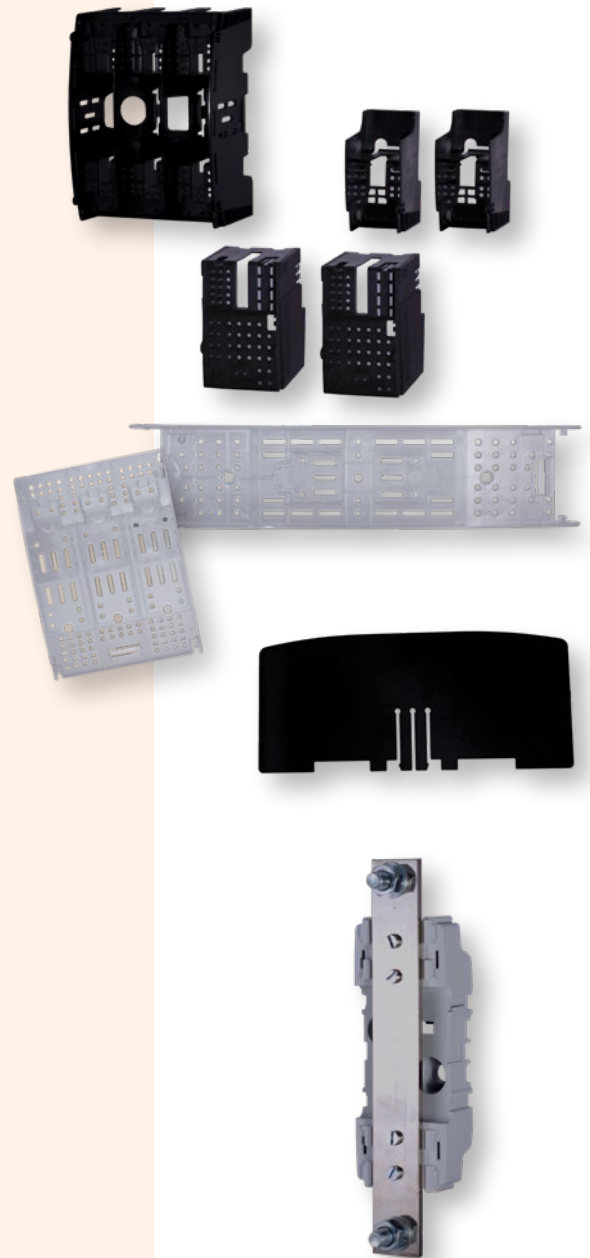

Neutral terminal base / Earth clamp

Type	I_n [A]	Code No.	Weight [g/pc]	Packaging [pcs]
PT 00/0 M8-2M5	160	004941502	124	3
PT 1/0 M10-M10	250	004941503	396	3
PT 2/0 M10-M10	400	004941504	570	3
PT 3/0 M12-M12	630	004941505	609	3

Plastic fuse bases type PLNVV 000 and 00 (fuses with screw connection - S)

Rated voltage
690 V

1-pole PLNVV 000 and 00 (fuses with screw connection - S)

Type	I_n [A]	Code No.	Weight [kg/pc]	Package [pcs]
PLNVV – 000/1 A	160	001701010	0,51	3
PLNVV – 00/1 A	160	001701020	0,58	3

* fuse bases PLNVV have no special accessories but only protective barriers Type ZP

** all bases are ready for mounting on mounting plate

*** with use of TS NP-00 is possible to mount fuse bases size 00 on the 35mm mounting rail



Neutral terminal base PLNS

Rated voltage
690 V



PLNS - 00

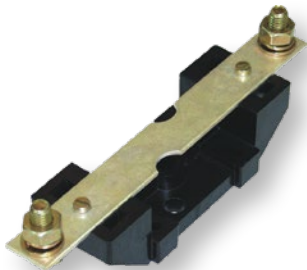

2PLNS - 1,2,3

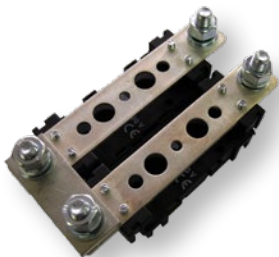

C-PLNS-00 + 2x PLNS-00N A



Neutral terminal bases PLNS 00, 1, 2

Type	I _n [A]	Code No.	Weight [kg/pc]	Packaging [pcs]
PLNS - 00N A	160	001701150	0,61	5
PLNS - 00N B	160	001701151	0,56	5
PLNS - 00N C	160	001701152	0,62	5
PLNS - 00N D	160	001701153	0,63	5
PLNS - 00N E	160	001701154	0,64	5
PLNS - 00N F	160	001701155	0,64	5
PLNS - 00N G	160	001701156	0,65	5
PLNS - 00N H	160	001701157	0,66	5
2PLNS - 1N A	250	001701158	0,60	5
2PLNS - 1N B	250	001701159	0,59	5
2PLNS - 1N C	250	001701160	0,60	5
2PLNS - 1N D	250	001701161	0,61	5
2PLNS - 1N E	250	001701162	0,62	5
2PLNS - 1N F	250	001701163	0,63	5
2PLNS - 1N G	250	001701164	0,64	5
2PLNS - 1N H	250	001701165	0,64	5
2PLNS - 1N K	250	001701180	0,66	5
2PLNS - 2N A	400	001701166	0,81	5
2PLNS - 2N B	400	001701167	0,76	5
2PLNS - 2N C	400	001701168	0,84	5
2PLNS - 2N D	400	001701169	0,86	5
2PLNS - 2N E	400	001701170	0,88	5
2PLNS - 2N F	400	001701171	0,89	5
2PLNS - 2N G	400	001701172	0,89	5
2PLNS - 2N H	400	001701173	0,90	5
2PLNS - 2N K	400	001701181	0,91	5

* basic Type is 1-pole and can be composed to multipole

** for connector description A, B, ... K see table of connections PLNV

*** C-PLNS-00 is used to equalize potential between N and PE terminal through M8 screw Type connection (see table of accessories)

Neutral terminal base with separation function PLNSR 00

Type	Code No.	Weight [kg/pc]	Package [pcs]
PLNSR-00 A	001701182	0,13	5
PLNSR-00 B	001701175	0,12	5
PLNSR-00 C	001701183	0,13	5
PLNSR-00 D	001701184	0,14	5
PLNSR-00 E	001701185	0,14	5
PLNSR-00 F	001701186	0,15	5
PLNSR-00 G	001701187	0,15	5
PLNSR-00 H	001701188	0,16	5

* supplied standard variant is 1-pole, 3-pole shall be made by instalments

** for connector description A, B, ... K see table of connections PLNV

Type of connections PLNVV and PLNS

Type of connection for fuse bases PLNV and PLNS

Connection	Size	One side of fuse base			Other side of fuse base		
		Description	Type	Drawing	Description	Type	Drawing
A	00	screw	M8		screw	M8	
	1		M10			M10	
	2		M10			M10	
	3		M12			M12	
B	00	clip terminal	OS00		clip terminal	OS00	
	1		OS12			OS12	
	2		OS12			OS12	
C	00	clip terminal	OS00		screw	M8	
	1		OS12			M10	
D	00	screw	M8		prism clamp	P00	
	1		M10			P1	
	2		M10			P2	
	3		M12			P3	
E	00	screw	M8		prism clamp	P002*	
	1		M10			P12	
	2		M10			P22	
	3		M12			P32	
F	00	prism clamp	P00		prism clamp	P00	
	1		P1			P1	
	2		P2			P2	
	3		P3			P3	
G	00	prism clamp	P00		prism clamp	P002*	
	1		P1			P12	
	2		P2			P22	
	3		P3			P32	
H	00	prism clamp	P002*		prism clamp	P002*	
	1		P12			P12	
	2		P22			P22	
	3		P32			P32	
K	1	»V« shaped clamp			»V« shaped clamp		
	2						

Connections:

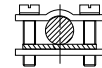

OS00 6 - 50 mm² - Cu
OS12 ... 25 - 150 mm² - Cu

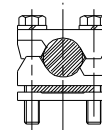

P00 ... 10 - 70 mm² - Cu / Al
P1 70 - 150 mm² - Cu / Al
P2 ... 120 - 240 mm² - Cu / Al
P3 ... 120 - 300 mm² - Cu / Al

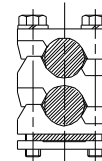

P002 ... 2 x (10 - 50 mm²) - Cu / Al
P12 2 x (70 - 95 mm²) - Cu / Al
P22 ... 2 x (120 - 150 mm²) - Cu / Al
P32 ... 2 x (120 - 240 mm²) - Cu / Al

* IK00 protective cover is only as high as the terminals 2x (10-25mm² = height of approx. 25mm)

** interchangeability of the terminals is only possible between type OS... and P... within the same base size. Replacing the terminal with screw M... with the terminal OS... or with terminal P... is not possible.

*** »V« shaped clamp is not interchangeable.

Accessories for PLNVV, PLNS

Type	Description	Code No.	Used in combination with	Weight [kg/pc]	Packaging [pcs]
TS NP-00	Mounting set (mounting on 35mm mounting rail)	001701221	PLNV 00, PLNVV - 000, 00	0,01	3
C-PLNS-00	Linking element to equalize potential between N and PE terminal	001701222	PLNS-00N	0,02	5

* for mounting 1-pole PLNVV, PLNS on 35mm mounting rail one set of TS NP-00 is needed.

** C-PLNS-00 is used to equalize potential between N and PE terminal through M8 screw Type connection on PLNS-00N base.

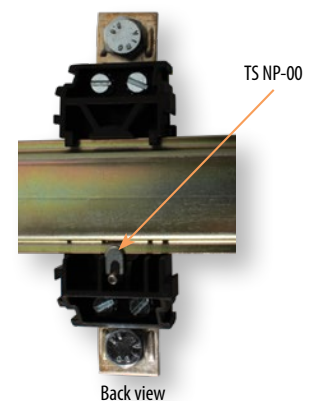

TS NP-00



C-PLNS-00

Accessories



NV/NH separator uninsulated

Type	I _N [A]	Code No. (Ni)	Code No. (Ag)	Weight [g]	Packaging [pcs]
NVL 00	160	004941230	004941235	75,5	20
NVL 0	160	004941231	004941236	120	20
NVL 1	250	004941232	004941237	145,5	20
NVL 2	400	004941233	004941238	210	20
NVL 3	630	004941234	004941239	275	6/48
NVL 4	1250	004941208		692	5
NVL 4a	1600	004941209		553	5

*size NVL 00, 0,1,2,3...drawing A in technical data
size NVL 4, 4a...drawing B in technical data



NV/NH separator insulated

Type	I _N [A]	Code No.	Weight [g]	Packaging [pcs]
NVLI 00 Ag*	160	004941220	70	5/60
NVLI 0 Ag*	160	004941221	120	5/40
NVLI 1 Ag*	250	004941222	145	5/40
NVLI 2 Ag*	400	004941223	215	5/40
NVLI 3 Ag*	630	004941224	315	5/40

*silver plated



Handle

Type	I _N [A]	Code No.	Weight [g]	Packaging [pcs]
R 00-3	2-630	004941111	276	10
VRRN 00-3*	2-630	001691061	320	1
VRRL 85	25-160	001691064	550	1

*handle with sleeve

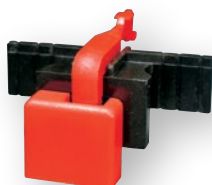

Signal Switch NVS 5

Type	Code No.	Weight [g]	Packaging [pcs]
NVS 5	004117001	11,5	10/340

NVS 5 is used for signalling of interruption of fuse-links of the Type NV/NH of the size NV/NH 00 C to NV/NH 3 (except NV/NH 1 ultra with knives for fastening with screws). NVS is activated through the indicator spring. We also offer Electronic Fuse Monitors - see page 140.

Protection link

Type	Code No.	Weight [g]	Packaging [pcs]
NVL00	004941206	30	10
NVL 1-3	004941207	78	10

Base separating elements

Type	Code No.	Weight [g]	Packaging [pcs]
PP 00, PK 00	004941301	50	20/100
PK 0	004941302	50	20/100
PK 1	004941303	50	20/100
PK 2	004941304	50	20/100
PK 3	004941305	50	20/100



Low voltage fuse-rails

NV/NH fuse-rail sizes 00, 1, 2, 3

Characteristics of LV NV fuse-rails

The LV NV/NH fuse-rails are 3-pole bases of LV fuse-links, intended for busbar mounting. The LV NV/NH fuse-rails comprises three single-pole connections in one unit. Each contact at an individual phase is connected to the phase on the busbar system. The other contacts are fitted with cable connecting terminals or intended for attachment of the following busbar system.

Use

The LV NV/NH fuse-rails are mainly used for cable distribution and power supply systems.

Principle of operation

The LV NV/NH fuse-rails are intended for insertion of LV fuse-links that are inserted and removed from the LV NV/NH fuse-rails by means of a special handle (refer to Catalogue ETI - LV fuse-links, Code No. number 4941111 and 4941100).

Design of LV NV/NH fuse-rails

The insulated supporting body is made of one piece, the material is polyester reinforced with glass fibres. A silver-plated contact system, fitted with tinned extinction chambers, ensures a low power dissipation, optimum thermal characteristics, and a high breaking capacity. The contact derived parts are intended for cable connections or for attachment of the next busbar system. All the live parts are protected against accidental contacts - in conformity with BVG A2. A special form of the contact part cover provides for safe insertion and removal of the LV fuse-links.

Short description

The LV NV/NH fuse-rails are manufactured in compliance with the DIN 43623 standard, and are mostly used for installation into cable distribution cabinets and power supply systems.

They are available in sizes of 00/160 A to 3/630 A. Covers provide insulation protection for all live parts.

All the LV NV/NH fuse-rails are fitted with new, modern Delta contact systems allowing optimum pressure contact between the fuse cartridge and the LV NV/NH fuse-rails, resulting in extremely low level of power dissipation and heating-up.

All standard insulated LV NV/NH fuse-rails shown in the Catalogue are intended for general usage.

Upon request appropriate individual configurations can be designed - in such cases please contact our sales engineers, or call us to the factory.

Advantages

- upper or lower cable connection - as required
- optimum pull contact
- simple installation
- modular design



General LV NV/NH fuse-rail table

Size	Code No.	Busbar system	Product designation	Connection description	Protection cover	Weight [kg]	Packaging [pcs]
00	001691015	100	VL00/100 M8-2	flat connection – screw M8	/	0,8	1/1
00	001691016	100	VL00/100 SP.95-2	prism 35 - 95 mm ²	/	0,8	1/1
00	001691020	185	VL00 M8	flat connection – screw M8	/	1,5	1/1
00	001691021	185	VL00 SP.95	V-clip 10-95 mm ²	/	1,5	1/1
1	001691024	185	VL1 M10	screw M10	terminal compartment cover	3,5	1/1
1	001695280	185	VL1H M10*	screw M10	terminal compartment cover	3,5	1/1
1	001691025	185	VL1 SP.300	V-clip 25-300 mm ²	terminal compartment cover	3,5	1/1
2	001691022	185	VL2 M12	screw M12	terminal compartment cover	3,8	1/1
2	001695290	185	VL2H M12*	screw M12	terminal compartment cover	3,8	1/1
2	001691029	185	VL2 M12x35	screw M12x35	terminal compartment cover	3,8	1/1
2	001691030	185	VL2 SP.240 P	V-clip 25-240 mm ²	terminal cover	3,8	1/1
2	001691031	185	VL2 SP.300	V-clip 25-300 mm ²	terminal compartment cover	3,8	1/1
3	001691027	185	VL3 M12	screw M12	terminal compartment cover	4,3	1/1
3	001691028	185	VL3 SP.300	V-clip 25-300 mm ²	terminal compartment cover	4,3	1/1

* H - "Omega" contact (make short - circuit current 80 kA)

Table of accessories for LV NV/NH fuse-rails

Type	Code No.	Description	Packaging [pcs]
busbar connection KS 00/5-10	001691040	busbar thickness 5-10mm	1/3
busbar connection KS 123/10	001692460	busbar thickness 10mm	1/1
protection covering of contact connections ZPL 123/10HA	001691045	for sizes 1,2,3	1/1
busbar covering PZ 00/185	001691046	mounting thread M8	1/1
busbar covering PZ 00/100	001691047	mounting thread M8	1/1
busbar covering PZ 123/185	001691048	mounting thread M12	1/1
busbar support POP 100/185	001691055	for busbar system 100 mm and 185 mm	1/1
protection covering of POP busbar support ZP POP 100	001691056	Lateral cover for busbar support 100 mm	1/1
protection covering of POP busbar support ZP POP 185	001691057	Lateral cover for busbar support 185 mm	1/1



busbar support



busbar connection



busbar covering

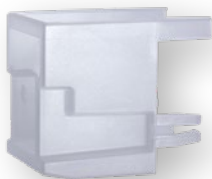

protection covering of contact connections

Busbar connection

Busbar connections are used for drill-free direct contacting of the strip-fuseways on the busbars.

Protection cover

The terminal compartment and terminal covers provide probe-safe frontal protective covering of the terminal compartment.

Busbar cover, screw-Type

The screw-Type covers of 100 mm width are fixed at busbars with M12 thread or stud. The covers of 50 mm width are fixed on busbars or adapters with M8 thread.

Busbar support

The 3-pole busbar support is used for the fixing of flat bars at 100 mm and 185 mm distances.

NV/NH fuse-rail type VL00 EK

Description

Fuse-rail type VL00/100 EK is a three-pole fuse-base in vertical design for mounting on busbar system. Intended for use with fuse-links size 000 (00C), 00 fuse-rail protects equipment in electrical circuits from overload and short circuit. Special designed contact cover enables safe manipulation with fuse-links (insertion / pull out) with special handle.

Application

- transformer substation
- distribution boards, distribution panels
- public lightening cabinets
- cable distribution cabinets
- industry

Mounting

Rails can be mounted on 100mm busbar system directly, with additional adapters can be mounted also to 185mm busbar system. Mounting in vertical and horizontal position.

Standards

VL00/100 EK are in accordance with the following standards:

- IEC 60947-1
- IEC 60947-3
- IEC 60269-1
- IEC 60269-2.

Fuse-rail type VL00/100 EK

Type	Code No.	Weight [g]	Packaging [pcs]
VL00/100 EK M8	001701600	0,95	1
VL00/100 EK BT00 10-70	001701601	0,95	1
VL00/100 EK OS00 6-50	001701602	0,94	1
VL00/100 EK P00 10-70	001701603	0,94	1
VL00/100 EK P002 50	001701605	0,96	1



*VL00/100 EK fuse-rails are used only for 100mm busbar system

** VL00/100 EK is possible to mount on 185mm busbar using special adapters

*** for type of terminals see table of terminal for SL00/100 EK and VL00/100 EK

**** busbar connection for drill-free direct contacting of the fuse-rail is not at disposal

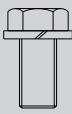

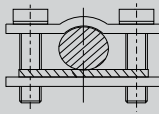
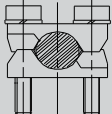
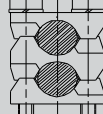
Table of connections for SL00/100 EK and VL00/100 EK

Cable terminal drawing					
Cable terminal type	M8	BT00 10-70*	OS00 6-50	P00 10-70	P002 50
Clamping cross-section	70 mm ²	10-70 mm ² Al/Cu	(6-50) mm ² Cu	(10-70) mm ² Al/Cu	2x50 mm ² Al/Cu
Screw type	M8x12	M6	2x(M5x14)	2x(M5x25)	2x(M5x40)
Tightening torque	12-15 Nm	4,5 Nm	2,6 Nm	4,5 Nm	4,5 Nm
Package	3	3	3	3	3

* connection type BT00 10-70 have to be ordered with the product, latter exchange is not possible

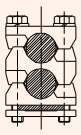

VL00/100 EK M8

Additional connections for VL00/100 EK				
Type	Code No.	Connector drawing	Suitability	Packaging [pcs]
OS00 6-50	001701480	 Cu*	SL00/100 EK VL00/100 EK	set = 3
P00 10-70	001701481	 Al/Cu*	SL00/100 EK VL00/100 EK	set = 3
P002 50	001701467	 Al/Cu*	SL00/100 EK VL00/100 EK	set = 3

* cable type for direct connection is indicated on the connector drawing
 ** exchange between connection Type is possible

Accessories for VL00/100 EK				
Type	Code No.	Description	Weight [kg/pc]	Package [pcs]
PRS-SL/VL EK	001701470	Protection cover for connection terminals	0,05	1
RA-1 100/185	001701471	Mounting adapter for 185mm busbar, single	0,25	1
RA-2 100/185	001701472	Mounting adapter for 185mm busbar, double	0,60	1

* PRS-SL/VL EK is needed for additional protection covering when using mountin adapter RA-...
 ** RA-1 100/185 is adapter that is needed if one SL00/100 EK or VL00/100 EK have to be mounted on 185mm busbar.
 With adapter RA-2 100/185 two SL00/100 EK or VL00/100 EK can be mounted on 185mm busbar same time.



Example:

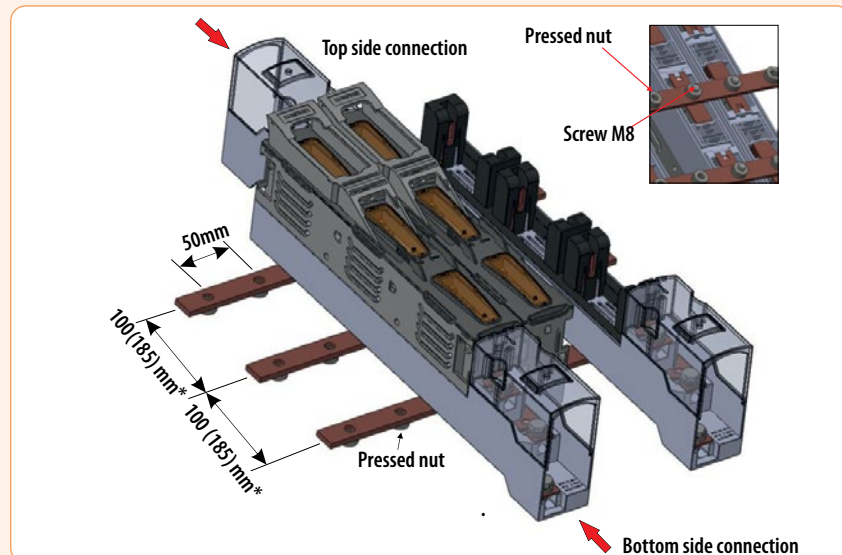

Strip type fuse-switch-disconnectors

NV/NH Strip type fuse-switch-disconnector sizes 00, 1, 2, 3

Characteristics of the NV/NH Strip type fuse-switch-disconnectors

The NV/NH Strip type fuse-switch-disconnectors are 3-pole bases of NV/NH fuse cartridges, intended for busbar mounting. An NV/NH Strip type fuse-switch-disconnectors comprises three single-pole connections in one unit. Each contact at an individual phase is connected to the phase on the busbar system. The other contacts are fitted with cable connecting terminals or intended for attachment of the following busbar system.

Use

The NV/NH Strip type fuse-switch-disconnectors are mainly used for cable distribution and power supply systems, transformer systems, where they are connected when electric energy transmission is required. The following rated currents are available: 160 A, 250 A, 400 A, 630 A.

Principle of operation

The NV/NH Strip type fuse-switch-disconnectors are used in combination with NV/NH fuse cartridges protecting the circuit against shorts. The upper part of the NV/NH Strip type fuse-switch-disconnectors with insulation class IP3X is provided with a separate test opening through which the live state can be tested according to DIN VDE 0680, part 5.

Design of the NV/NH Strip type fuse-switch-disconnectors

The insulated supporting body is made of one piece, the material is polyester reinforced with glass fibres. A silver-plated contact system, fitted with tinned extinction chambers, ensures a low power dissipation, optimum thermal characteristics and a high breaking capacity. The contact derived parts are intended for cable connections or for attachment of the next busbar system. All the live parts are protected against accidental contacts - in conformity with BVG A2. A special form of the contact part cover ensures a safe insertion and removal of the NV/NH fuse cartridges.

Short description

The NV/NH Strip type fuse-switch-disconnectors are mostly used for installation into cable distribution cabinets and power supply systems - in accordance with IEC/EN 61439-1. The NV/NH Strip type fuse-switch-disconnectors have been tested in accordance with IEC/EN 60947-3. They are available for the sizes of fuse cartridges from 00 to 3, with both single-pole and 3-pole switching-on.

Advantages

- upper or lower cable connection - as required
- optimum pull contact
- direct connection
- double strip connection up to 1250 A
- universal cover
- high breaking capacity
- low power dissipation
- use of standard earthing connections
- modular construction

Main types of the NV/NH Strip type fuse-switch-disconnectors - characteristics

Basically, as shown, there are several types of the NV/NH Strip type fuse-switch-disconnectors:

- for a 3-pole switching-in
- for a single-pole switching-in
- for attachment directly to a busbar system
- with side contacts for a busbar system

All the NV/NH Strip type fuse-switch-disconnectors are fitted with new, modern Delta contact systems allowing optimum pressure contact between the fuse cartridge and the NV/NH Strip type fuse-switch-disconnectors, resulting in extremely low level of power dissipation and heating-up. All the standard NV/NH Strip type fuse-switch-disconnectors shown in the catalogue are intended for general usage. Upon request appropriate individual configurations can be designed - in such cases please contact our sales engineers, or call us to the factory.

Influence of ambient temperature on rated current of NH strip-type fuse-switch-disconnectors

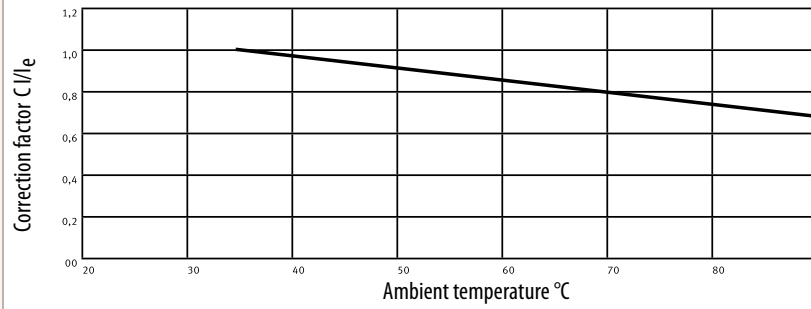

Rated diversity factor accc to IEC EN 61439-2:2012-06 table 101

No. of main circuits	Rated diversity factor
2 & 3	0,9
4 & 5	0,8
6 ... 9	0,7
10 ≤	0,6

General table of NV/NH strip type-fuse-switch-disconnector-single-pole switching-in

Size	Code No.	Busbar system	Product designation	Product designation	Switch lever	Weight [kg]	Packaging [pcs]
00	001692010	185	SL00 1P M8	flat connection - screw M8	standard	2,4	1/1
00	001692012	185	SL00 1P SP.95	V-clip 10-95 mm ²	standard	2,4	1/1
1	001692110	185	SL1 1P M10	screw M10	standard	4,9	1/1
1	001695200	185	SL1H 1P M10*	screw M10	standard	4,9	1/1
1	001692111	185	SL1 1P SP.300	V-clip 25-300 mm ²	standard	4,9	1/1
1	001695201	185	SL1H 1P SP.300*	V-clip 25-300 mm ²	standard	4,9	1/1
1	001692112	185	SL1 1P SP.240	V-clip 25-240 mm ²	standard	4,9	1/1
1	001695202	185	SL1H 1P SP.240*	V-clip 25-240 mm ²	standard	4,9	1/1
2	001692210	185	SL2 1P M12	screw M12	standard	4,9	1/1
2	001695220	185	SL2H 1P M12*	screw M12	standard	4,9	1/1
2	001692211	185	SL2 1P SP.300	V-clip 25-300 mm ²	standard	4,9	1/1
2	001695221	185	SL2H 1P SP.300*	V-clip 25-300 mm ²	standard	4,9	1/1
2	001692212	185	SL2 1P SP.240	V-clip 25-240 mm ²	standard	4,9	1/1
2	001695222	185	SL2H 1P SP.240*	v-clip 25-240 mm ²	standard	4,9	1/1
3	001692310	185	SL3 1P M12	screw M12	standard	5,6	1/1
3	001692311	185	SL3 1P SP.300	V-clip 25-300 mm ²	standard	5,6	1/1
3	001692312	185	SL3 1P SP.240	V-clip 25-240 mm ²	standard	5,6	1/1

* H - "Omega" contact (make short - circuit current 80 kA)

General tabel of NV/NH Strip type fuse-switch-disconnector-three-pole switching-in

Size	Code No.	Busbar system	Product designation	Connection description	Weight [kg]	Packaging [pcs]
00	001692034	100	SL00/100 3P M8-2	flat connection - screw M8	1	1/1
00	001692035	100	SL00/100 3P SP.70-2	V-clip 10-70 mm ²	1	1/1
00	001692032	185	SL00 3P M8	flat connection - screw M8	2,4	1/1
00	001692033	185	SL00 3P SP.95	V-clip 10-95 mm ²	2,4	1/1
1	001692130	185	SL1 3P M10	screw M10	4,9	1/1
1	001695210	185	SL1H 3P M10 *	screw M10	4,9	1/1
1	001692131	185	SL1 3P SP.300	V-clip 25-300 mm ²	4,9	1/1
1	001695211	185	SL1H 3P SP.300*	V-clip 25-300 mm ²	4,9	1/1
1	001692132	185	SL1 3P SP.240	V-clip 25-240 mm ²	4,9	1/1
1	001695212	185	SL1H 3P SP.240*	V-clip 25-240 mm ²	4,9	1/
2	001692000	185	SL2 3P SP.300	V-clip 25-300 mm ²	4,9	1/1
2	001695231	185	SL2H 3P SP.300*	V-clip 25-300 mm ²	4,9	1/1
2	001692230	185	SL2 3P M12	screw M12	4,9	1/1
2	001695230	185	SL2H 3P M12*	screw M12	4,9	1/1
2	001692231	185	SL2 3P SP.240	V-clip 25-240 mm ²	4,9	1/1
2	001695232	185	SL2H 3P SP.240*	V-clip 25-240 mm ²	4,9	1/1
3	001692330	185	SL3 3P M12	screw M12	5,6	1/1
3	001692331	185	SL3 3P SP.300	V-clip 25-300 mm ²	5,6	1/1
3	001692332	185	SL3 3P SP.240	V-clip 25-240 mm ²	5,6	1/1

* H - "Omega" contact (make short - circuit current 80 kA)



Strip type fuse-switch-disconnectors

NV/NH Strip type fuse-switch-disconnector with current transformer

Size	Code No.	Busbar system	Product designation	Connection description	Current transformer	Weight [kg]	Packaging [pcs]
00	001693000	100	SL00/100 3P M8 150/5 Kl.1	flat connection, M8	150/5 class 1	1,7	1/1
1	001693010	185	SL1 3P M10 250/5 Kl.1	screw M10	250/5 class 1	3,1	1/1
2	001693020	185	SL2 3P M12 400/5 Kl.1	screw M12	400/5 class 1	4,6	1/1
3	001693030	185	SL3 3P M12 600/5 Kl.1	screw M12	600/5 class 1	4,6	1/1
00	001693040	100	SL00/100 3P SP:70 150/5 Kl.1	V-clip 10-70mm ²	150/5 class 1	1,7	1/1
1	001693050	185	SL1 3P SP:300 250/5 Kl.1	V-clip 25-300mm ²	250/5 class 1	3,1	1/1
2	001693060	185	SL2 3P SP:300 400/5 Kl.1	V-clip 25-300mm ²	400/5 class 1	4,6	1/1
3	001693070	185	SL3 3P SP:300 600/5 Kl.1	V-clip 25-300mm ²	600/5 class 1	4,6	1/1

Table of accessories for NV Strip type fuse-switch-disconnector

Type	Code No.	Description	Packaging [pcs]
busbar connection KS 00/5-10	001691040	busbar thickness 5-10mm	3
busbar connection KS 123/10	001692460	for size 1,2,3	1/1
adapter DA 185/185 42	001692411	for system 185 mm height 42 mm	1/1
adapter DA 185/100 52	001692412	for system 185/100mm, height 52 mm, for 2 x SL00	1/1
protection covering of contact connections ZP 00 HA BOTTOM	001692420	for size 00; used when cable connects from the bottom	1/1
protection covering of contact connections ZP 00 HA TOP	001692424	for size 00; used when cable connects from the top	1/1
protection covering of contact connections ZP 123/10HA	001692421	for size 1,2,3; universal - for top / bottom cable connections	1/1
busbar covering PZ 00/185	001691046	mounting thread M8	1/1
busbar covering PZ 00/100	001691047	mounting thread M8	1/1
busbar covering PZ 123/185	001691048	mounting thread M12	1/1
nameplate NP 123	001692431	for size 1,2,3	1/1
busbar support POP 100/185	001691055	for systems 100 mm and 185 mm	1/1
Deriv. connection OP L	001692440	for size 1,2,3	1/1
double connection DP 3x2 (6)*	001692450	for size 1,2,3	1/1
double protection cover ZP 3x2/10HA*	001692422	for size 1,2,3	1/1
double terminal connections SPD 2x3 3x300	001692423	for size 1,2,3	1/1
micro switch MST SL00/100 3p**	001691050	open/close position of SL	1/1
micro switch MST SL00 3p**	001691051	open/close position of SL	1/1
micro switch MST SL123 3p**	001691052	open/close position of SL	1/1
protection covering of POP busbar support ZP POP 100	001691056	Lateral cover for busbar support 100 mm	1/1
protection covering of POP busbar support ZP POP 185	001691057	Lateral cover for busbar support 185 mm	1/1
SP SL123 M/2x95-150	001692452	Retrofit kit for 2 conductors	1/1
SP SL123 M/2x240	001692453	Retrofit kit for 2 conductors	1/1
SP SL123 V/2x95-150	001692454	Retrofit kit for 2 conductors	1/1
SP SL123 V/2x150-240	001692455	Retrofit kit for 2 conductors	1/1

* accessories for assembling: SL 1250 (2 parallel connected fuse-switch-disconnectors)

** one MST can be installed inside SL

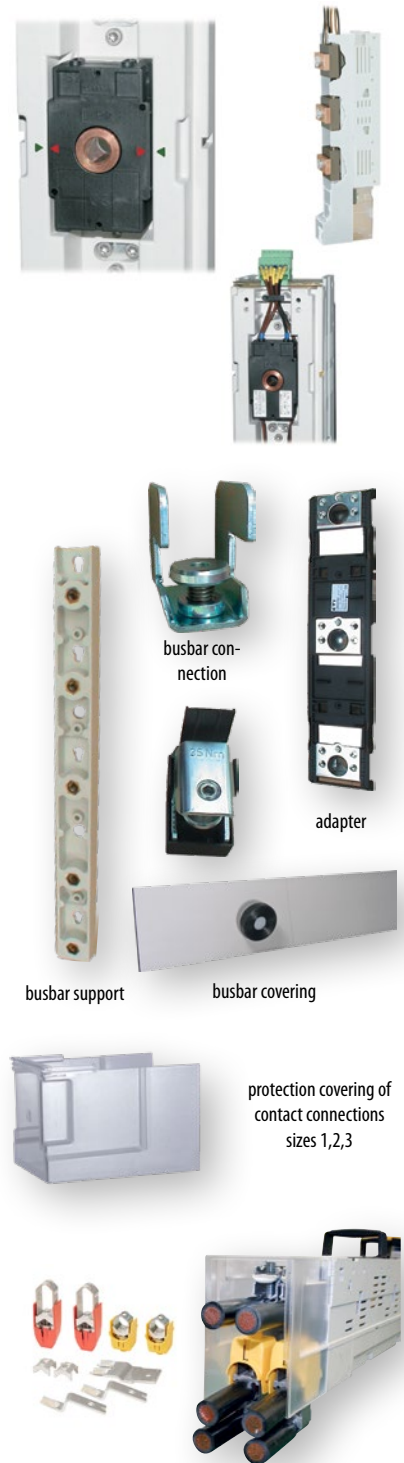

BUSBAR CONNECTION

Busbar connections are used for drill-free direct contacting of the strip-fuseways on the busbars.

PROTECTION COVER

The terminal compartment and terminal covers provide probe-safe frontal protective covering of the terminal compartment.

BUSBARCOVER, SCREW-TYPE

The screw-type covers of 100 mm width are fixed at busbars with M12 thread or stud. The covers of 50 mm width are fixed on busbars or adapters with M8 thread.

BUSBAR SUPPORT

The 3-pole busbar support is used for the fixing of flat bars at 100 mm and 185 mm distances.

DOUBLE CONNECTOR

The connector kits are used for parallel switching of 2 strips.

DOUBLE TERMINAL CONNECTION

The kit for 1250 A allows 2 strips to be connected at the terminal and 3 or 4 cables per phase to be connected.

NAMEPLATE

The designation plate mount is plugged on the strips at the end face. It allows fitting of an additional designation plate. When fitted in switch boards, it can also be used as support for a system cover.

BUSBAR ADAPTERS

The adapters are required for combining different strip sizes, e.g. size 00 with sizes 1 to 3.

DERIVED CONNECTION

The derived connection enables fuse-protected temporary connections (worksite electrical supply) to size 1 to 3 LV NV strip-fuseways.

Strip type fuse-switch disconnectors type SL00 EK

Characteristics of the NV/NH Strip type fuse-switch-disconnectors

Strip type fuse-switch disconnector SL00/100 EK is a three-pole low-voltage switching device which enables safely manual connecting and disconnecting electrical circuits under load, depending on voltage and utilization category. It's purpose is protection of low voltage electrical equipment against specified overload currents and short circuit currents using fuse-links size 000 (00C), 00. SL00/100 EK are three-pole switching.

Application

Strip type fuse-switch disconnectors are intended for:

- transformer substation
- distribution boards, distribution panels
- public lightening cabinets
- cable distribution cabinets
- industry

Mounting

Strip type fuse-switch disconnectors can be mounted on 100mm busbar system directly and with additional adapters can be mounted also to 185mm busbar system. Mounting in vertical and horizontal position.

Standards

SL00/100 EK are in accordance with the following standards:

- IEC 60947-1
- IEC 60947-3
- IEC 60269-1
- IEC 60269-2



SL00/100 EK

Fuse-switch disconnector strip type SL00/100 EK, three pole switching

Type	Code No.	Weight [g]	Packaging [pcs]
SL00/100 EK 3p M8	001701500	1,20	1
SL00/100 EK 3p BT00 10-70	001701501	1,20	1
SL00/100 EK 3p OS00 6-50	001701502	1,10	1
SL00/100 EK 3p P00 10-70	001701503	1,10	1
SL00/100 EK 3p P002 50	001701505	1,30	1



* SL00/100 EK strip type fuse-switch disconnectors are used only for 100mm busbar system

** SL00/100 EK is possible to mount on 185mm busbar using special adapters

*** for Type of terminals see table of terminal for SL00/100 EK and VL00/100 EK

**** busbar connection for drill-free direct contacting of the strip type fuse-switch disconnector is not at disposal

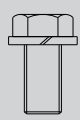

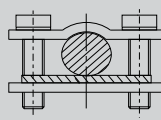
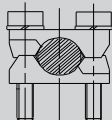
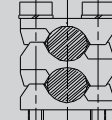
Table of connections for SL00/100 EK and VL00/100 EK

Cable terminal drawing					
Cable terminal type	M8	BT00 10-70*	OS00 6-50	P00 10-70	P002 50
Clamping cross-section	70 mm ²	10-70 mm ² Al/Cu	(6-50) mm ² Cu	(10-70) mm ² Al/Cu	2x50 mm ² Al/Cu
Screw type	M8x12	M6	2x(M5x14)	2x(M5x25)	2x(M5x40)
Tightening torque	12-15 Nm	4,5 Nm	2,6 Nm	4,5 Nm	4,5 Nm
Package	3	3	3	3	3

* connection type BT00 10-70 have to be ordered with the product, latter exchange is not possible

Strip type fuse-switch-disconnectors

Additional connections for SL00/100 EK

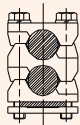
Type	Code No.	Connector drawing	Suitability	Packaging [pcs]
OS00 6-50	001701211	 Cu*	SL00/100 EK VL00/100 EK	set = 3
P00 10-70	001701213	 Al/Cu*	SL00/100 EK VL00/100 EK	set = 3
P002 50	001701467	 Al/Cu*	SL00/100 EK VL00/100 EK	set = 3

* cable Type for direct connection is indicated on the connection drawing

** exchange between connection Type is possible

Accessories for SL00/100 EK

Type	Code No.	Description	Weight [kg/pc]	Package [pcs]
PRS-SL/VL EK	001701470	Protection cover for connection terminals	0,05	1
RA-1 100/185	001701471	Mounting adapter for 185mm busbar, single	0,25	1
RA-2 100/185	001701472	Mounting adapter for 185mm busbar, double	0,60	1

* PRS-SL/VL EK is needed for additional protection covering when using mountin adapter RA-...

** RA-1 100/185 is adapter that is needed if one SL00/100 EK or VL00/100 EK have to be mounted on 185mm busbar. With adapter RA-2 100/185 two SL00/100 EK or VL00/100 EK can be mounted on 185mm busbar same time.



RA-1 100/185



PRS-SL/VL EK

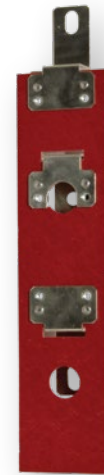

RA-2 100/185

Example:

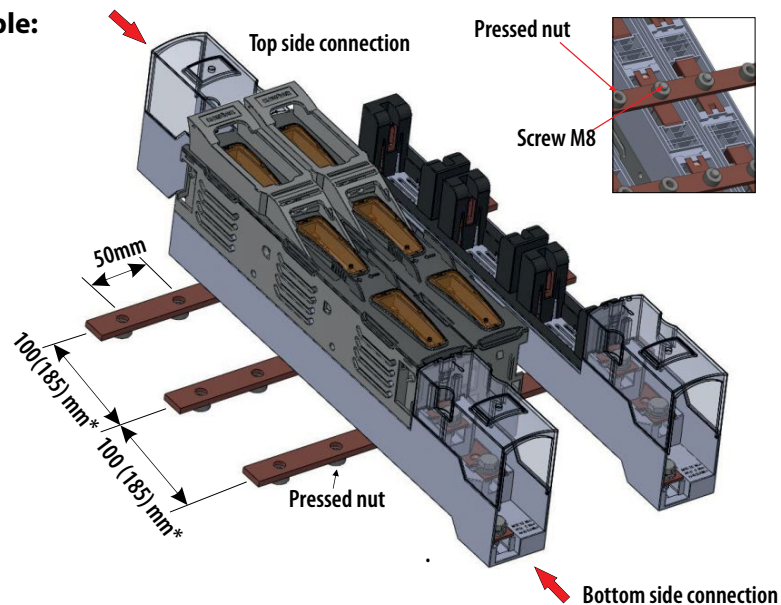

NV/NH disconnectors with fuses

NV/NH horizontal fuse-switch disconnectors KVL

Uniform cover cutout
 KVL - horizontal fuse-switch disconnectors with different sizes can be combined together and form uniform cover cutout. The new assortment contains four cover support levels at 32, 60, 70 and 90 mm above the upper of busbar. KVL fuse-switch disconnectors can be mounted on baseplates and DIN rails (for busbars see chapter ETIBUSBAR).

- Available with 1-, 2-, 3-, 4- pole versions
- Four sizes: size 00, size 1, size 2, size 3
- Use with NV/NH Fuse-links 000, 00, 1, 2, 3

Baseplate and DIN-rail mounting
 KVL disconnectors have multiple mounting holes for variability of installations. KVL-00 and KVL-1 can also be mounted on two parallel DIN-rails.



<p>KVL size 00 Ie = 160A Overall width: 106mm System size: 195mm</p>	<p>KVL size 1 Ie = 250A Overall width: 184mm System size: 300mm</p>	<p>KVL size 2 Ie = 400A Overall width: 210mm System size: 300mm</p>	<p>KVL size 3 Ie = 630A Overall width: 250mm System size: 300mm</p>
---	--	--	--

Practical advantages



Easy voltage measurements
 - Easy access with standard voltage Testers.
 Window in the handle is movable.
 - Protection degree IP2XC in normal operating condition



Safety lock
 - Prevents unauthorized operation
 - Can be used for all sizes



Simple and practical parking position
 - Safe parking position of the handle
 - Accidental reclosing not possible

Montage on DIN rails
 - Time saving installation
 - KVL-00 and KVL-1 can fit on the same TH rails

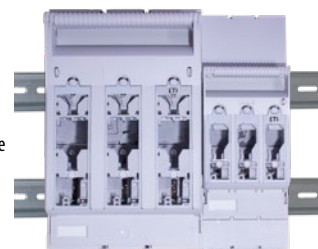

New generation!

Advantages

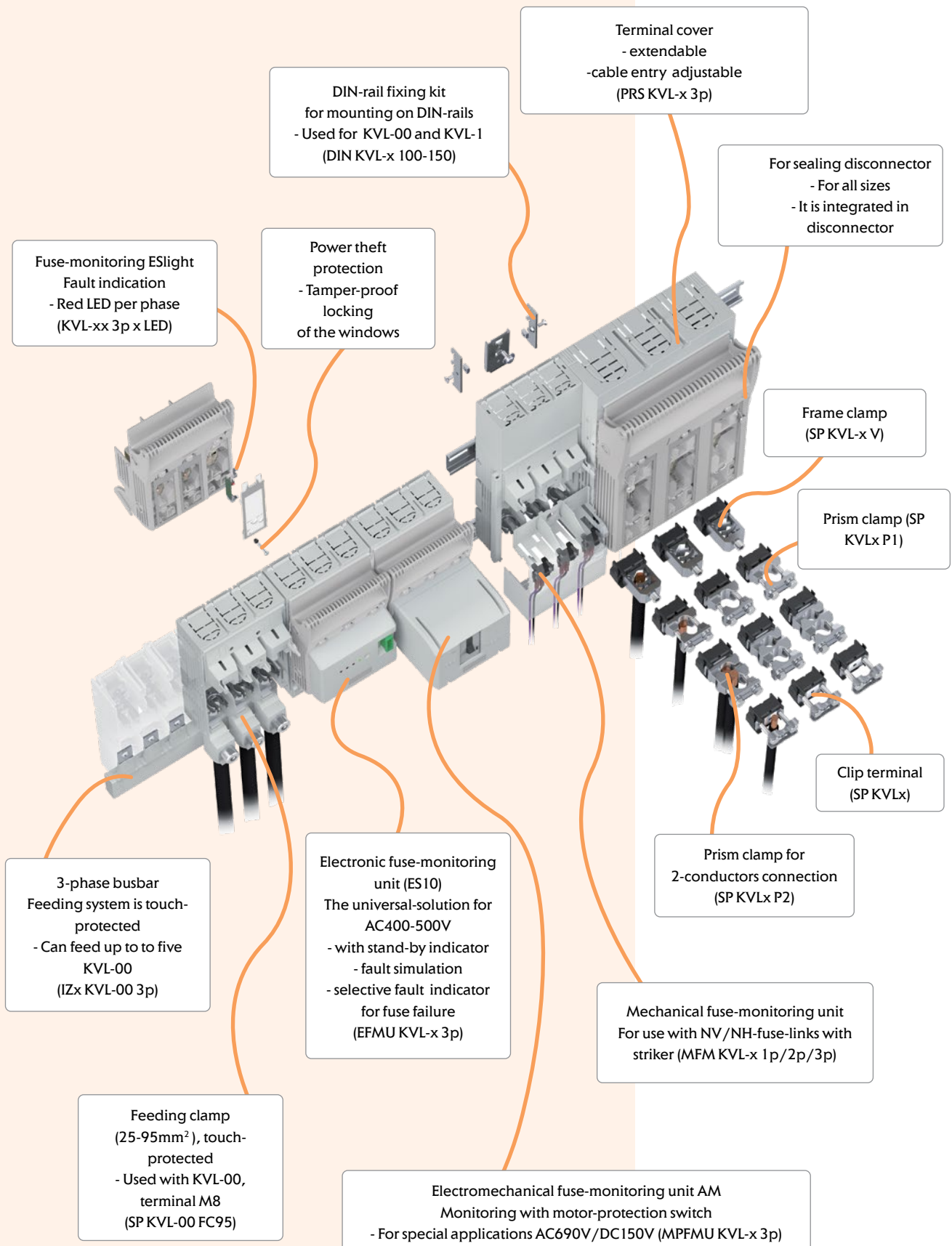

NV/NH

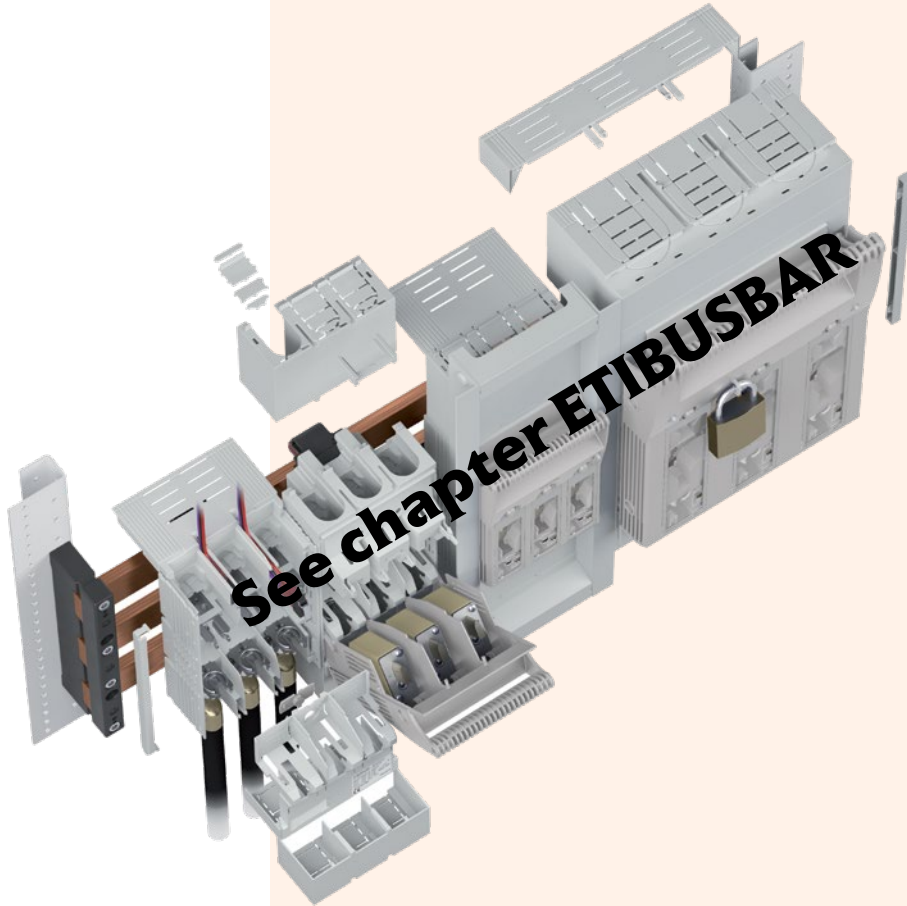

Derating factor: to operate the fuse switch disconnecter in horizontal mounted position
 The fuse switch disconnecters are designed to operate in both horizontal as well as vertical mounted positions. However the main field of application is for vertical mounting because the heat dissipation on this type of mounting is considerably low. To operate them on horizontal mounted position a derating factor has to be taken in to consideration.

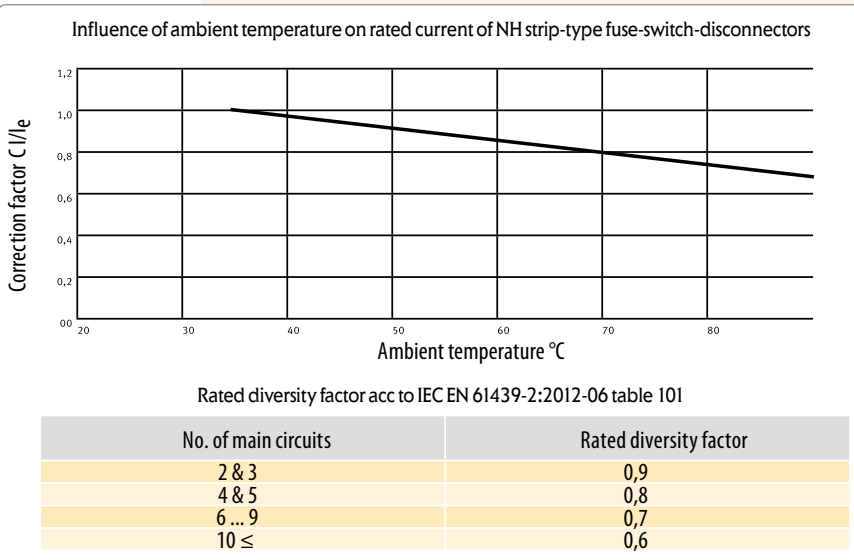
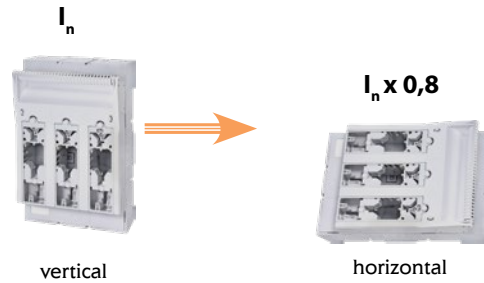

NV/NH disconnectors with fuses

3-pole, Baseplate mounting

Size	Code No.	Type	Weight [kg]	Packaging [pcs]
00	001690870	KVL-00 3p M8-M8	0,63	1
	001690871	KVL-00 3p BC95-BC95	0,67	1
1	001690872	KVL-1 3p M10-M10	2,03	1
2	001690873	KVL-2 3p M10-M10	3,42	1
3	001690874	KVL-3 3p M10-M10	3,95	1
4a	001692620	HVL4a 3P M16 1250	15,7	1
4a	001692630	HVL4a 3P 2xM12 1600	15,7	1

3-pole, Baseplate mounting, LED indication

Size	Code No.	Type	Weight [kg]	Packaging [pcs]
00	001690880	KVL-00 3p M8-M8 LED	0,66	1
	001690881	KVL-00 3p BC95-BC95 LED	0,7	1
1	001690882	KVL-1 3p M10-M10 LED	2,06	1
2	001690883	KVL-2 3p M10-M10 LED	3,45	1
3	001690884	KVL-3 3p M10-M10 LED	3,92	1

! Only used for 400 V AC
! Not used for DC

1-pole, Baseplate mounting

Size	Code No.	Type	Weight [kg]	Packaging [pcs]
00	001690890	KVL-00 1p M8-M8	0,31	2
1	001690891	KVL-1 1p M10-M10	0,93	1
2-3	001690892	KVL-3 1p M10-M10	1,57	1
4a	001692498	HVL4a 1P M16 1250A	5,3	1
4a	001692499	HVL4a 1P 2xM12 1600A	5,3	1

2-pole, Baseplate mounting

Size	Code No.	Type	Weight [kg]	Packaging [pcs]
00	001690895	KVL-00 2p M8-M8	0,72	1
1	001690896	KVL-1 2p M10-M10	1,88	1
2-3	001690897	KVL-3 2p M10-M10	3,19	1

4-pole, Baseplate mounting

Size	Code No.	Type	Weight [kg]	Packaging [pcs]
00	001690900	KVL-00 4p M8-M8	1,19	1
1	001690901	KVL-1 4p M10-M10	2,91	1
2-3	001690902	KVL-3 4p M10-M10	5,76	1



BC95-BC95





PRS KVL-00 1p



PRS KVL-00 1p S



SP KVL



SP KVL...P1



DIN KVL-00 100-150



SP KVL-1 V



SP KVL-23 V



SP KVL-00 FC95



MTB KVL00
2x25/1x16/M8



MTB KVL00
4x10/M8



I2Z KVL-00 3p

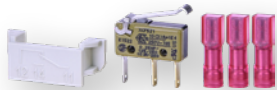

MST KVL- ...



MFM KVL-123 1p 2p 3p



PRS KVL-... 3p



CK KVL-00 2p/4p

Accessories for KVL

Type	Code No.	Description	Packaging min order [pcs]
SP KVL00	001692701	Clip terminal, 1,5 – 50 mm ² Cu	3
SP KVL1	001692702	Clip terminal, 25– 150 mm ² Cu	3
SP KVL2	001692703	Clip terminal, 25– 240 mm ² Cu	3
SP KVL3	001692704	Clip terminal, 11x21 mm ² Cu	3
SP KVL00 P1	001692760	Prism clamp, 10 – 70 mm ² Al/Cu	3
SP KVL1 P1	001692761	Prism clamp, 70 – 150 mm ² Al/Cu	3
SP KVL2 P1	001692762	Prism clamp, 120 – 240 mm ² Al/Cu	3
SP KVL3 P1	001692763	Prism clamp, 120 – 300 mm ² Al/Cu	3
SP KVL1 P2	001692764	Prism clamp for 2-conductors connection, 2x70 – 95 mm ² Al/Cu	3
SP KVL2 P2	001692765	Prism clamp for 2-conductors connection, 2x120 – 150 mm ² Al/Cu	3
SP KVL3 P2	001692766	Prism clamp for 2-conductors connection, 2x120 – 240 mm ² Al/Cu	3
SP HVL 4a D2	001692767	Direct terminal clamp for 2-conductors connection, 2x120 – 300mm ² Al/Cu	1
SP HVL 4a D3	001692768	Direct terminal clamp for 3-conductors connection, 3x95 – 150 mm ² Al/Cu	1
SP HVL 4a D4	001692769	Direct terminal clamp for 4-conductors connection, 4x95 – 150 mm ² Al/Cu	1
SP KVL-1 V	001690940	Frame clamp, 35-150mm ² Al/Cu	3
SP KVL-23 V	001690941	Frame clamp, 95-300mm ² Al/Cu	3
SP KVL-00 FC95	001690942	Feeding clamp, 25-95mm ² Cu/Al, isolated, terminal M8,*	3
MTB KVL00 2x25/1x16/M8	001690978	Terminal block with multiple wire connections	3
MTB KVL00 4x10/M8	001690979	Terminal block with multiple wire connections	3
I2Z KVL-00 3p	001690943	Phase busbars, 2 x 3pole KVL-00 50mm ²	5
I23 KVL-00 3p	001690944	Phase busbars, 3 x 3pole KVL-00 50mm ²	5
I24 KVL-00 3p	001690945	Phase busbars, 4 x 3pole KVL-00 50mm ²	3
I25 KVL-00 3p	001690946	Phase busbars, 5 x 3pole KVL-00 50mm ²	3
MST KVL-00 1p	001690947	Switch position indicator, 1-pole, size 00, **	1
MST KVL-00 3p	001690948	Switch position indicator, 3-pole, size 00, **	1
MST KVL-123 1p/2p/3p	001690949	Switch position indicator, 1/2/3 -pole, size 1, 2, 3, **	1
MST 4a 1p+3p	001692714	Switch position indicator + mechanical fuse monitor, size 4a, 1p/3p	1
MFM KVL-00 1p/2p/3p	001690950	Mechanical fuse monitor, size 00, **	3
MFM KVL-123 1p/2p/3p	001690951	Mechanical fuse monitor, size 1, 2, 3, **, ***	3
PRS KVL-00 3p L	001690952	Terminal cover, 3-pole, variable to open, Length 66mm, size 00	2
PRS KVL-00 3p S	001690953	Terminal cover, 3-pole, variable to open, Length 36mm, size 00	2
PRS KVL-1 3p	001690954	Terminal cover, 3-pole, variable to open, Length 42mm, size 1	2
PRS KVL-2 3p	001690955	Terminal cover, 3-pole, variable to open, Length 42mm, size 2	2
PRS KVL-3 3p	001690956	Terminal cover, 3-pole, variable to open, Length 42mm, size 3	2
PRS KVL-00 1p L	001690957	Terminal cover, 1-pole, variable to open, Length 66mm, size 00	2
PRS KVL-00 1p S	001690958	Terminal cover, 1-pole, variable to open, Length 36mm, size 00	2
PRS KVL-1 1p	001690959	Terminal cover, 1-pole, variable to open, Length 42mm, size 1	2
PRS KVL-3 1p	001690960	Terminal cover, 1-pole, variable to open, Length 42mm, size 3	2
DIN KVL-00 100-150	001690964	DIN rail fixing parts, For mounting on DIN rails, size 00	3
DIN KVL-1 100-150	001690965	DIN rail fixing parts, For mounting on DIN rails, size 1	3
EFMU KVL-00 3p	001690966	Electronic fuse monitoring unit, 3-pole, size 00, ****	1
EFMU KVL-1 3p	001690967	Electronic fuse monitoring unit, 3-pole, size 1, ****	1
EFMU KVL-2 3p	001690968	Electronic fuse monitoring unit, 3-pole, size 2, ****	1
EFMU KVL-3 3p	001690969	Electronic fuse monitoring unit, 3-pole, size 3, ****	1
MPFMU KVL-00 3p	001690974	Elektromechanical fuse monitoring unit (AM), 3-pole, size 00, ****	1
MPFMU KVL-1 3p	001690975	Elektromechanical fuse monitoring unit (AM), 3-pole, size 1, ****	1
MPFMU KVL-2 3p	001690976	Elektromechanical fuse monitoring unit (AM), 3-pole, size 2, ****	1
MPFMU KVL-3 3p	001690977	Elektromechanical fuse monitoring unit (AM), 3-pole, size 3, ****	1
CK KVL-00 2p/4p	001690970	Connecting kit 2- and 4-pole, For making of 2- and 4-pole disconnectors, size 00	1
CK KVL-123 2p/4p	001690971	Connecting kit 2- and 4-pole, For making of 2- and 4-pole disconnectors, size 1, 2, 3	1
LP KVL-00123	001690972	Interlock device, locking with padlock, diameter 6mm max., size 00, 1, 2, 3	10
IC KVL-00123	001690973	Contact cover interlock, only be operated by tool, size 00-3	10

* Feeding clamp, AC690V/DC1000V-250A

** 1 Changeover, AC250V, 10/3A (ohmic/ind.)

*** Only in combination with ETI fuse-links with striker-pin; not in combination with frame-clamp or 2-wire-prism clamp.

**** For monitoring of fuse-links with live gripping lugs

! For other pictures of Accessories, see chapter ETIBUSBAR

Horizontal fuse-switch disconnecter type HVL EK size 000 and 00

Description

Horizontal fuse-switch disconnecter type HVL EK is a low voltage device that provides switching of the circuits, depending on the voltage and use categories. The main purpose of HVL EK is installation of the NH fuses size 000 and 00, and protection of equipment from the harmful effects of short circuit and overload. If instead of NH fuses NH separators are installed, HVL EK provides disconnection function and meets all regulatory requirements in the open position.

Fields of use and features

Horizontal fuse-switch disconnectors are designed for use in a number of applications that require disconnection function. They are suitable for challenging the scope of the external electrical junction boxes, and public lighting, security cable branches in industrial applications and for the separation of distribution metering cabinets.

The program of horizontal fuse-switch disconnectors type HVL EK includes sizes 000 and 00 and is intended for mounting on a mounting plate, DIN rails and 60 mm busbar system. The standard offer includes 1-pole, 3-pole and 4-pole versions. Available is a wide range of different connections allowing great flexibility in use. Horizontal fuse-switch disconnectors HVL EK meet the requirements of the following standards:

IEC 60947-1,
IEC 60947-3,
IEC 60269-1,
IEC 60269-2-1

In horizontal fuse-switch disconnecter type HVL EK 000 only NH knife-blade fuse links size 000 (00C) could be used while in horizontal fuse-switch disconnecter type HVL EK 00 sizes 00 and 000 (00C) could be used. About additional warnings on products see technical part of the catalogue.

3-pole horizontal fuse-switch disconnecter HVL EK 000

Type	Code No.	Weight [kg/pc]	Packaging [pcs]
HVL EK 000 3p M8	001701000	0,58	1
HVL EK 000 3p OS00 6-16	001701001	0,52	1
HVL EK 000 3p OS00 25-50	001701002	0,58	1
HVL EK 000 3p P00 10-35	001701003	0,62	1
HVL EK 000 3p P00 50-70	001701004	0,63	1
HVL EK 000 3p P002 10-16	001701005	0,66	1
HVL EK 000 3p P002 25-35	001701006	0,67	1

* HVL EK 000 are ready for mounting on mounting plate or mounting on 35mm mounting rail without accessories

** connections are described in table of connections for HVL EK 000

*** given Type connector for the HVL EK means same connectors on both sides of HVL EK

**** different combinations of connections on both sides of the separator can be made with terminals that are available as accessories

***** highest clamp that can be placed on top side is P002 25-35, and on bottom side P002 50

1-pole horizontal fuse-switch disconnecter HVL EK 000

Type	Code No.	Weight [kg/pc]	Packaging [pcs]
HVL EK 000 1p M8	001701400	0,23	3
HVL EK 000 1p OS00 6-16	001701401	0,22	3
HVL EK 000 1p OS00 25-50	001701402	0,22	3
HVL EK 000 1p P00 10-35	001701403	0,24	3
HVL EK 000 1p P00 50-70	001701404	0,24	3
HVL EK 000 1p P002 10-16	001701405	0,25	3
HVL EK 000 1p P002 25-35	001701406	0,25	3

* HVL EK 000 are ready for mounting on mounting plate or mounting on 35mm mounting rail without accessories

** connections are described in table of connections for HVL EK 000

*** two-pole design can be done using two single-pole

**** highest clamp that can be placed on top side is P002 25-35, and on bottom side P002 50





4-pole horizontal fuse-switch disconnecter HVL EK 000

Type	Code No.	Weight [kg/pc]	Packaging [pcs]
HVL EK 000 4p M8	001701420	0,82	1

- * HVL EK 000 are ready for mounting on mounting plate or mounting on 35mm mounting rail without accessories
- ** connections are described in table of connections for HVL EK 000
- *** switching off neutral pole (N) same time as switching phase polarity
- **** highest clamp that can be placed on top side is P002 25-35, and on bottom side P002 50

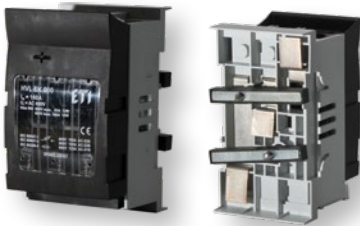

3-pole horizontal fuse-switch disconnecter HVL-B EK 000 (5-10mm Busbar)

Type	Code No.	Weight [kg/pc]	Packaging [pcs]
HVL-B EK 000 3p M8	001701011	0,85	1
HVL-B EK 000 3p BT00 10-70	001701012	0,88	1

- * HVL-B EK 000 are ready for mounting on 60mm busbar system, 5-10 mm thick
- ** connections are described in table of connections for HVL EK 000
- *** connector BT00 10-70 in combination with HVL-B EK have clamping cross-section up to 50mm².
- **** connecting from top/bottom (read installation manual carefully to avoid wrong connection!)
- ***** for additional remarks on product see technical part of the catalogue.
- ***** highest clamp that can be placed on top side is P002 25-35, and on bottom side P002 50

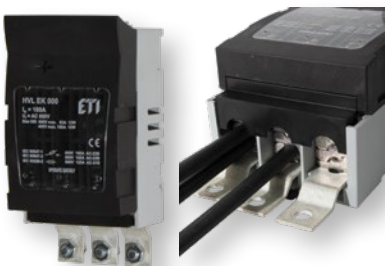

3-pole horizontal fuse-switch disconnecter HVL-P EK 000 (flat bar connection)

Type	Code No.	Weight [kg/pc]	Packaging [pcs]
HVL-P EK 000 3p M8	001701013	0,59	1
HVL-P EK 000 3p OS00 6-50	001701014	0,53	1
HVL-P EK 000 3p P00 10-70	001701015	0,59	1

- * HVL-P EK 000 are ready for mounting on mounting plate or mounting on 35mm mounting rail without accessories
- ** HVL-P EK 00 are supplied with extra protective covering of connectors on the bottom side (PRS EK 000/3)
- *** connections are described in table of connections for HVL EK 000
- **** highest clamp that can be placed on top side is P002 25-35, and on bottom side P002 50



Accessories for HVL EK 000

Type	Code No.	Description	Weight [kg/pc]	Packaging [pcs]	Min order [pcs]
PRS EK 000/1	001701450	Protecting cover, 1p	0,02	set = 2	1 set
PRS EK 000/3	001701451	Protecting cover, 3p	0,03	set = 2	1 set
PRS-B EK 000/3	001701452	Protecting cover, 3p	0,03	set = 2	1 set

- * PRS EK 000... to be used for HVL EK 000, supplied in pairs covering the TOP and BOTTOM side
- ** PRS-B EK 000 to be used for HVL-B EK 000, supplied in pairs covering the TOP and BOTTOM side

Table of connections for HVL EK 000

Cable terminal drawing																		
	Cable terminal type	M8	BT00 10-70	OS00 6-16	OS00 25-50	P00 10-35	P00 50-70	P002 10-16	P002 25-35	P002 50								
Cable terminal type	M8	BT00 10-70	OS00 6-16	OS00 25-50	P00 10-35	P00 50-70	P002 10-16	P002 25-35	P002 50									
Clamping cross-section	70 mm ²	10-50 mm ² Al/Cu	(6-16) mm ² Cu	(25-50) mm ² Cu	(10-35) mm ² Al/Cu	(50-70) mm ² Al/Cu	2x(10-16) mm ² Al/Cu	2x(25-35) mm ² Al/Cu	2x50 mm ² Al/Cu									
Screw type	M8x12	M6	2x(M5x12)	2x(M5x14)	2x(M5x20)	2x(M5x25)	2x(M5x25)	2x(M5x30)	2x(M5x35)									
Tightening torque	12-15 Nm	4,5 Nm	2,6 Nm	2,6 Nm	4,5 Nm	4,5 Nm	4,5 Nm	4,5 Nm	4,5 Nm									
Package	3	3	3	3	3	3	3	3	3									

- * basic type of HVL EK 000 is screw connection M8
- ** connector BT00 10-70 at disposal only in combination with HVL-B EK for busbar (HVL-B EK 000 3p BT00 10-70)
- *** HVL EK 00 allows an easy change of mutual connections (except BT00 10-70)

NV/NH disconnectors with fuses

3-pole horizontal fuse-switch disconnecter HVL EK 00

Type	Code No.	Weight [kg/pc]	Packaging [pcs]
HVL EK 00 3p M8	001701250	0,65	1
HVL EK 00 3p OS00 6-50	001701251	0,63	1
HVL EK 00 3p P00 10-70	001701252	0,69	1
HVL EK 00 3p P00 35-95	001701255	0,72	1
HVL EK 00 3p BT00 10-70	001701256	0,66	1

- * HVL EK 00 are ready for mounting on mounting plate
- ** basic Type of HVL EK 000 is screw connection M8
- *** connections are described in table of connections for HVL EK 00
- **** clamps that can be placed on top side are OS00 and P00, while on bottom side there is no limitation (see table range of connections for HVL EK 000/00)
- ***** For clamp limitation, see table of accessories

1-pole horizontal fuse-switch disconnecter HVL EK 00

Type	Code No.	Weight [kg/pc]	Packaging [pcs]
HVL EK 00 1p M8	001701410	0,28	3
HVL EK 00 1p OS00 6-50	001701411	0,26	3
HVL EK 00 1p P00 10-70	001701412	0,28	3
HVL EK 00 1p P00 35-95	001701415	0,30	3
HVL EK 00 1p BT00 10-70	001701416	0,28	3

- * HVL EK 00 are ready for mounting on mounting plate
- ** basic Type of HVL EK 000 is screw connection M8
- *** connections are described in table of connections for HVL EK 00
- **** two-pole design can be made using two single-pole
- ***** For clamp limitation, see table of accessories

4-pole horizontal fuse-switch disconnecter HVL EK 00

Type	Code No.	Weight [kg/pc]	Packaging [pcs]
HVL EK 00 4p M8	001701430	0,92	1
HVL EK 00 4p BT00 10-70	001701431	0,92	1

- * HVL EK 00 are ready for mounting on mounting plate
- ** basic Type of HVL EK 000 is screw connection M8
- *** connections are described in table of connections for HVL EK 00
- *** switching off neutral pole (N) same time as switching phase polarity
- ***** For clamp limitation, see table of accessories

3-pole horizontal fuse-switch disconnecter HVL-P EK 00 (additional flat bar connection)

Type	Code No.	Weight [kg/pc]	Packaging [pcs]
HVL-P EK 00 3p M8	001701260	0,67	1
HVL-P EK 00 3p OS00 6-50	001701261	0,65	1
HVL-P EK 00 3p P00 10-70	001701262	0,71	1

- * HVL-P EK 00 are ready for mounting on mounting plate
- ** HVL-P EK 00 are supplied without any extra protective covering of connectors
- *** connections are described in table of connections for HVL EK 00
- ***** For clamp limitation, see table of accessories

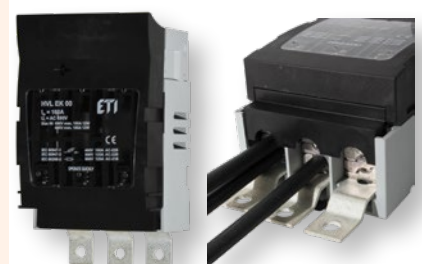

Example:

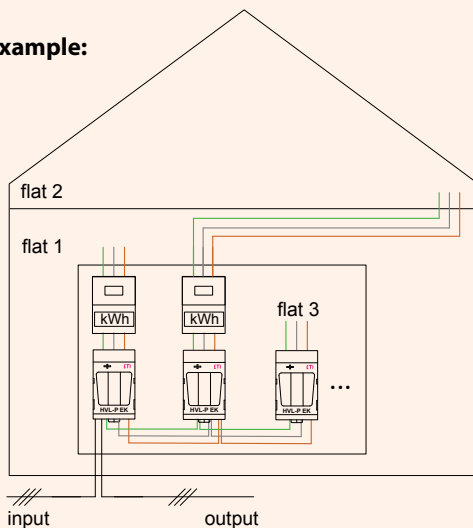

Accessories for HVL EK 00			
Type	Code No.	Description	Packaging [pcs]
DIN EK 00 125-150	001701453	Mounting brackets for mounting on two rails 35mm	1 set

* DIN EK 00 125-150 set allows to mount HVL EK 00 on two mounting rails in distance of 125mm or 150mm.

Table of connections for HVL EK 00

Cable terminal drawing							
Cable terminal type	M8	BT00 10-70*	OS00 6-50	P00 10-70	P00 35-95*	P002 10-35	P002 50
Clamping cross-section	70 mm ²	10-70 mm ² Al/Cu	(6-50) mm ² Cu	(10-70) mm ² Al/Cu	(35-95) mm ² Al/Cu	2x(10-35) mm ² Al/Cu	2x50 mm ² Al/Cu
Screw type	M8x12	M6	2x(M5x14)	2x(M5x25)	2x(M5x30)	2x(M5x30)	2x(M5x40)
Tightening torque	12-15 Nm	4,5 Nm	2,6 Nm	4,5 Nm	4,5 Nm	4,5 Nm	4,5 Nm
Package	3	3	3	3	3	3	3

* connections P00 35-95 and BT00 10-70 should be ordered with fuse-switch disconnector while latter exchange is not possible

** basic type of HVL EK 00 is screw connection M8

*** HVL EK 00 allows an easy change of mutual connections (except BT00 10-70 and P00 35-95)

Accessories for HVL EK 000/00 (connectors)

Type	Code No.	Connector drawing	Suitability	Packaging [pcs]
OS00 6-16	001701460		HVL EK 000	set = 3
OS00 25-50	001701461		HVL EK 000	set = 3
OS00 6-50	001701480		Cu**	HVL EK 00
P00 10-35	001701462		HVL EK 000	set = 3
P00 50-70	001701463		HVL EK 000	set = 3
P00 10-70	001701481		HVL EK 00	set = 3
P00 35-95*	001701464	Cu/Al**	HVL EK 00	set = 3
P002 10-16	001701465		HVL EK 000	set = 3
P002 25-35	001701466		HVL EK 000	set = 3
P002 10-35	001701482		HVL EK 00***	set = 3
P002 50	001701467		HVL EK 000, 00***	set = 3
P002 35-70*	001701468		Cu/Al**	HVL EK 00***

* because of wider screw distance change is only possible between these two Types of connections (however always possible to change connections OS with P00 and P002 and vice versa only the exceptions are marked with *)

** Type of cable for direct connection is given on connector drawing

*** Double prism clamp (P002) can be used only on bottom side of HVL EK 00, while on top side clamps (OS00 and P00) remain

Technical data

Fuse Links NV/NH

Electrical characteristics	
Rated voltage U_n	400 V AC, 500 V AC, 690 V AC
Rated current I_n	2 - 1600 A
Breaking capacity U_n	120 kA, 100 kA, 50 kA
Melting characteristic	gG, aM, gF, gTr
Certified	DIN VDE0636-201 (1998-06)
In accordance with	IEC 60269-1:2005 / EN 60269-1:1998+A1:2005 IEC 60269-2:1986+Corr.1:1996+A11995+A2:2001 / EN 60269-2:1995+A1:1998+A2:2002 IEC 60269-2-1:2004 / HD 60269-2-1:2005
Dimensions according to	DIN43620 Part: 1 - 4
Two versions of covers	aluminium and plastic

Fuse Links NV/NH gG Dimensions

Type	Dimensions											K	KOMBI
	A	B	C	D	E	F	G	H	I	J	K		
NV00C	79	53	47	35	15	21	52	7,5				6	KOMBI
NV00C I	79	53	47	35	15	21	52	7,5				6	KOMBI
NV00	79	53	47	35	15	28	56	12				6	KOMBI
NV00 I	79	53	47	35	15	28	56	12				6	KOMBI
NV0	125	68	65	35	15	28	56	12				6	KOMBI
NV1C	135	68	65	40	15	28	61	12				6	KOMBI
NV1C I	135	68	65	40	15	28	61	12				6	KOMBI
NV1	135	72	65	40	20	46	65	14				6	KOMBI
NV1 I	135	72	65	40	20	46	65	14				6	KOMBI
NV2C	150	72	65	48	20	46	73	14				6	KOMBI
NV2C I	150	72	65	48	20	46	73	14				6	KOMBI
NV2	150	72	65	48	26	54	73	14				6	KOMBI
NV2 I	150	72	65	48	26	54	73	14				6	KOMBI
NV3C	150	72	65	60	26	54	84	14				6	KOMBI
NV3	150	72	65	60	33	65	84	14				6	KOMBI
NV4	200	75	66	87	50	100	121	24	150	16	8		
NV4a	200	99	87	85	50	95	121	27				6	
NV4a SI*	200	99	87	85	50	95	121	27				6	

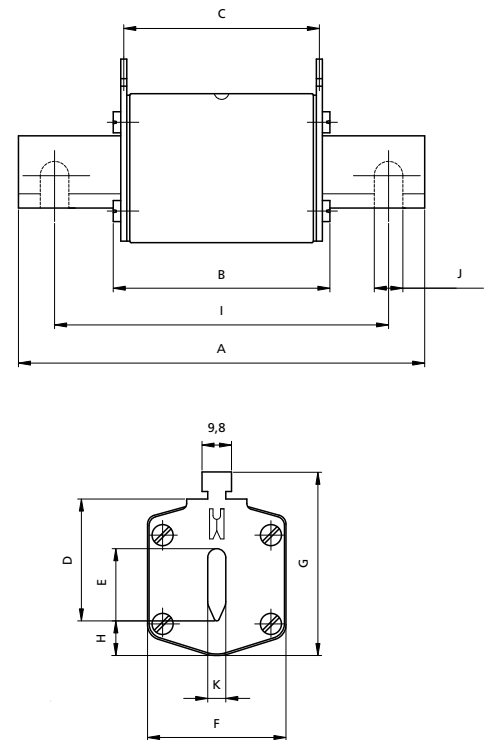

Fuse Links NV/NH gG with Striker Pin Dimensions

Type	Dimensions			
	K	L	M	S1
00C	0	20.7	16.7	7.5
00	0	20.7	16.7	7.5
1	13.7	19.7	25	12
2	16.2	27.4	25	12
3	17	35.6	25	12
4a	24	49	25	12

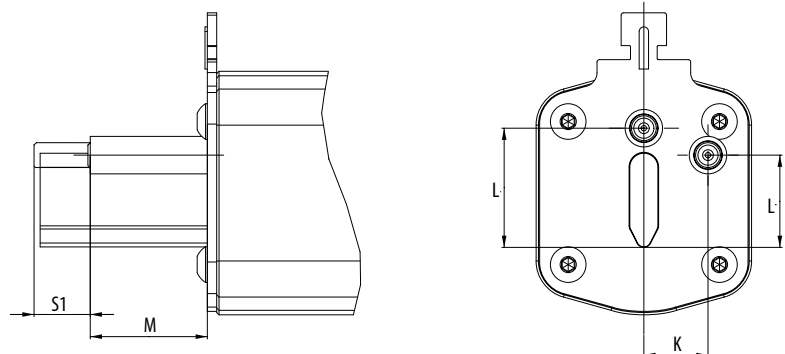

Fuse-link NV/NH gG characteristics

NH000 400V

Time current characteristics
I/t, gG

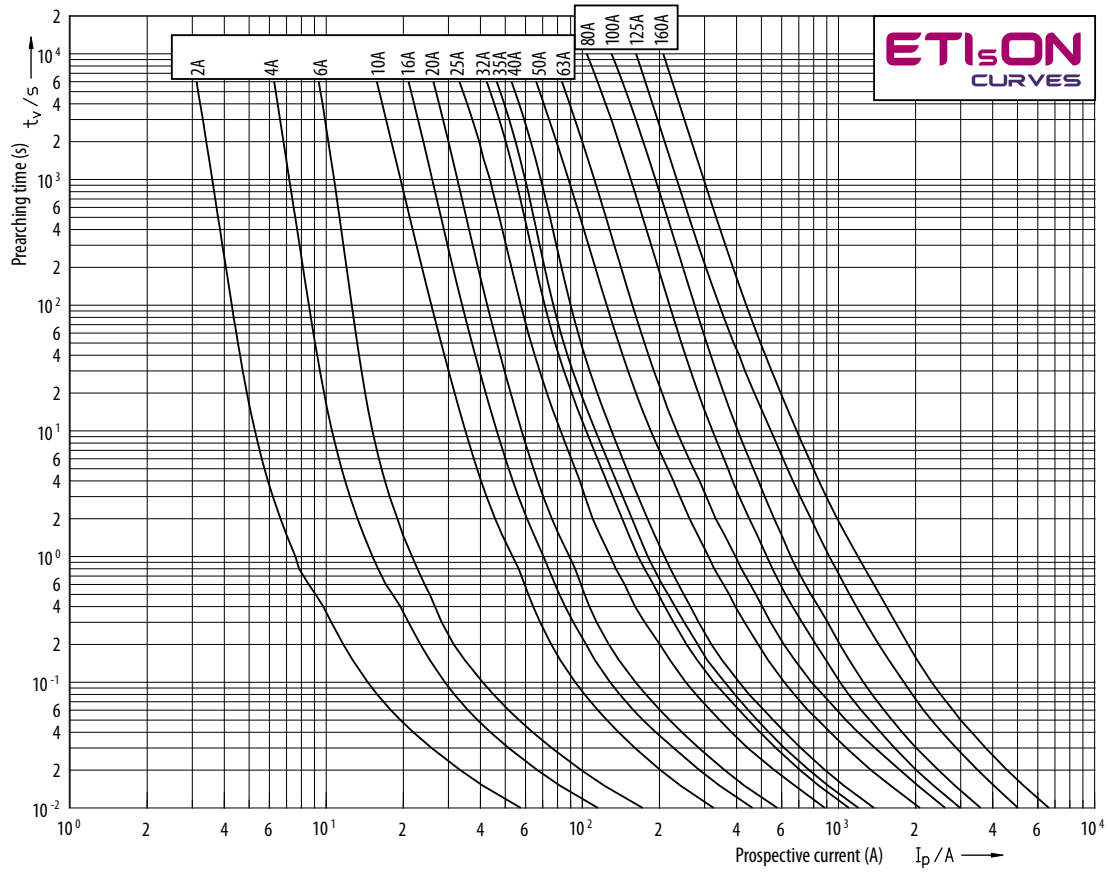

NH000 500V

Time current characteristics
I/t, gG

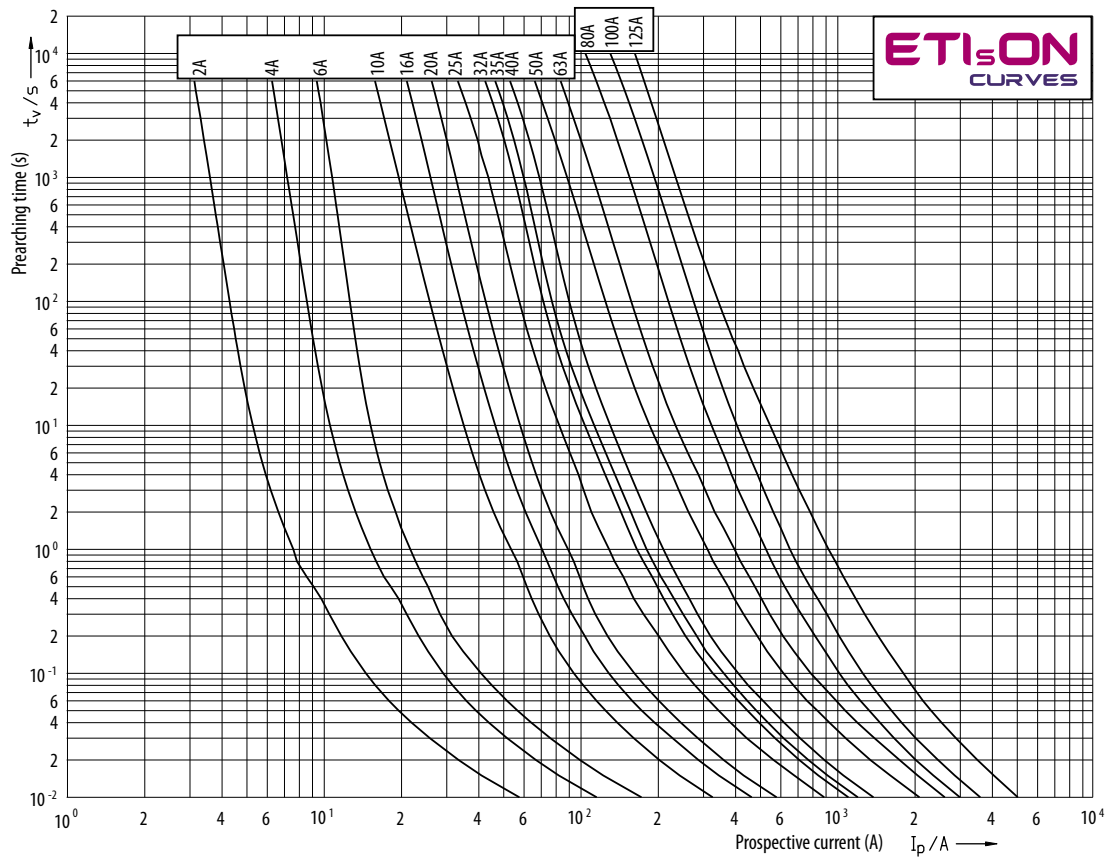

Technical data

NH000 690V

Time current characteristics
I/t, gG

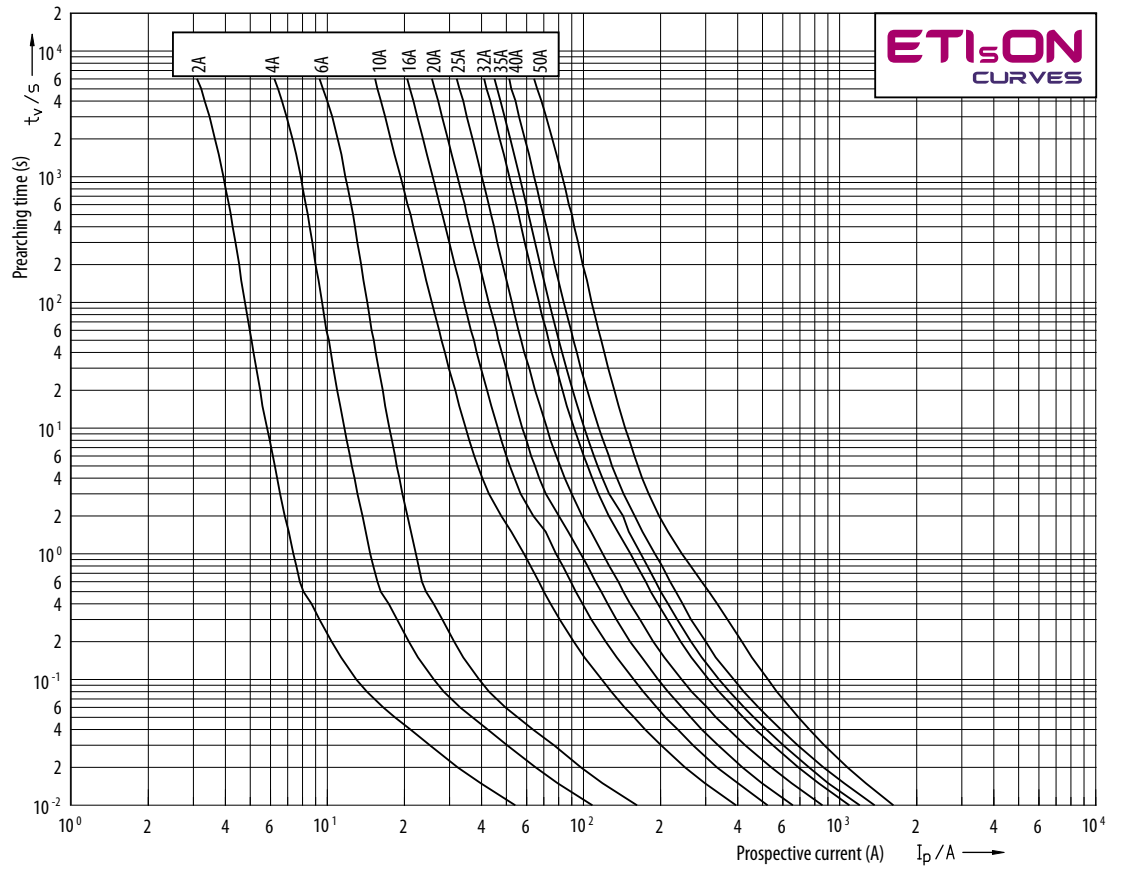

NH00 400V

Time current characteristics
I/t, gG

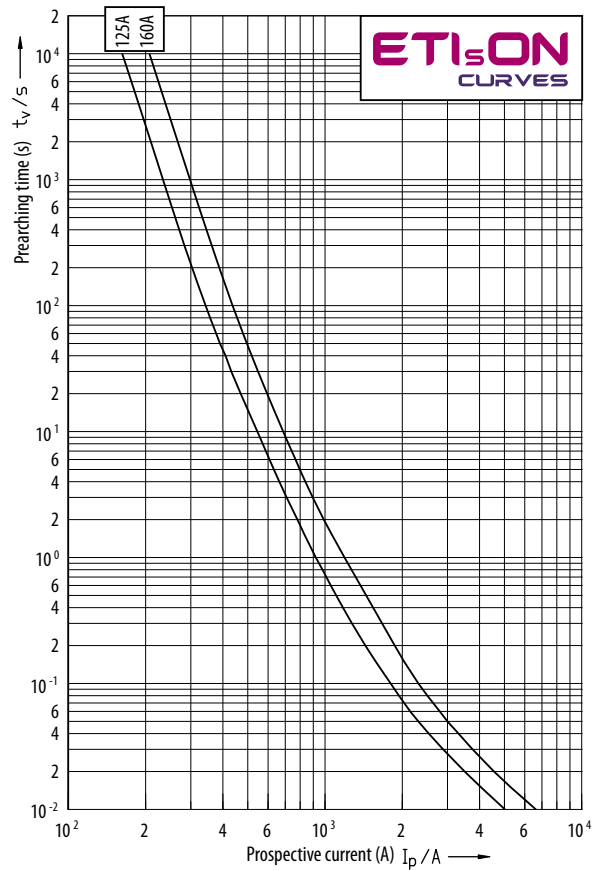

NH00 500V

Time current characteristics
I/t, gG

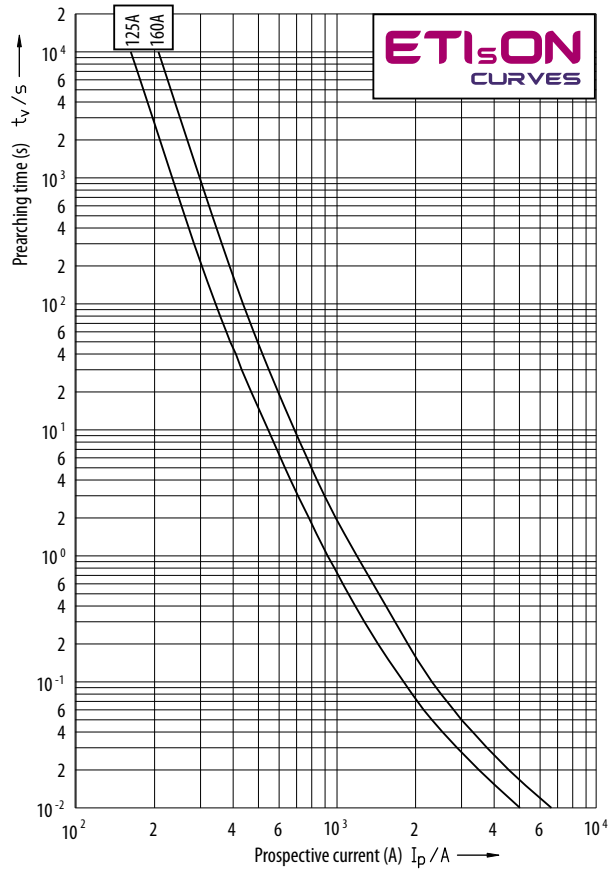

Technical data

NH00 690V

Time current characteristics
I/t, gG

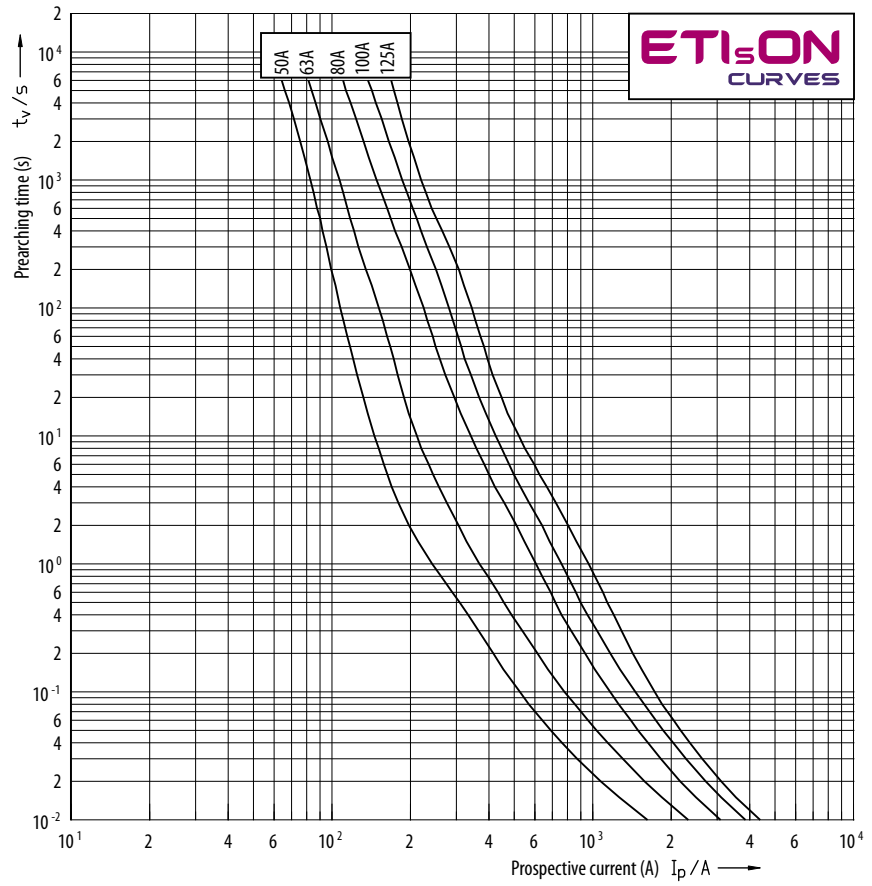

NH0, NH1C 400V

Time current characteristics
I/t, gG

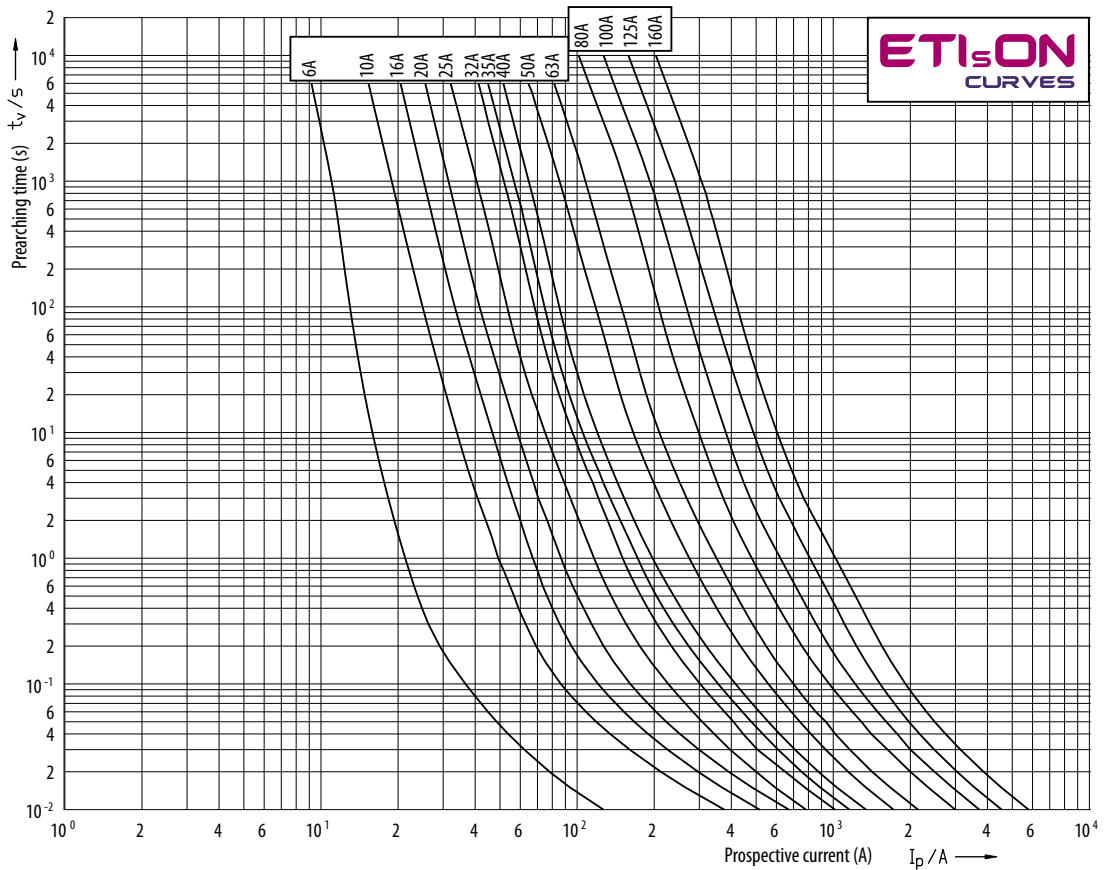

**NH0, NH1C
500V**

Time current characteristics
I/t, gG

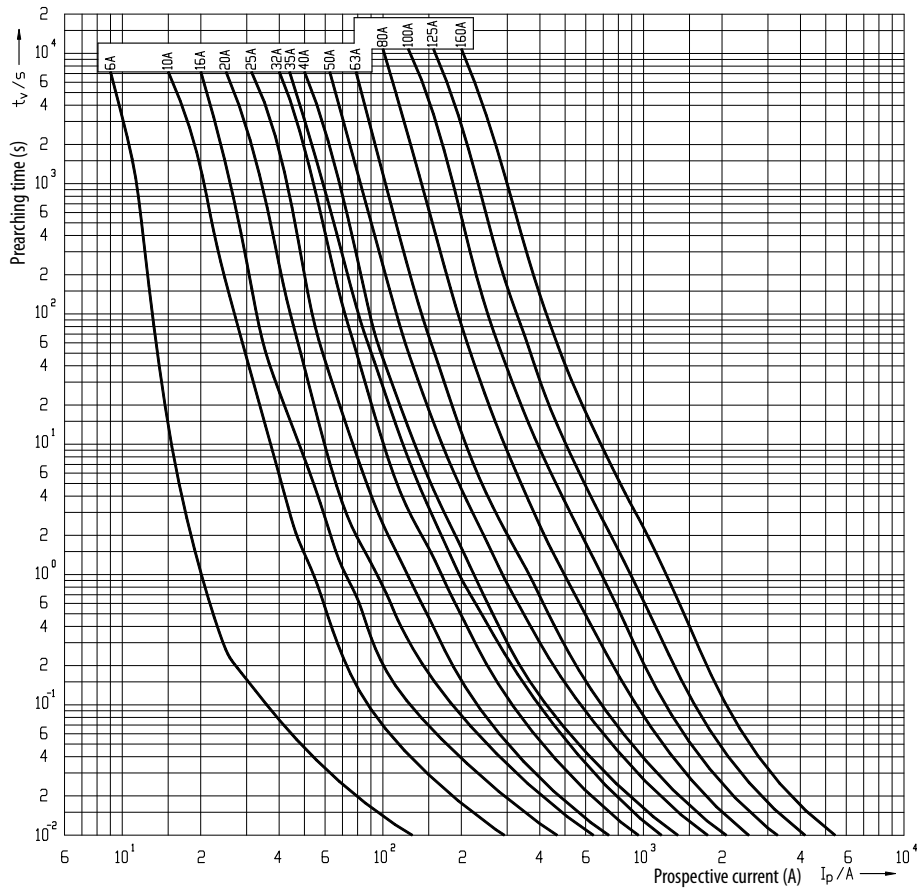

Cut-off current characteristics

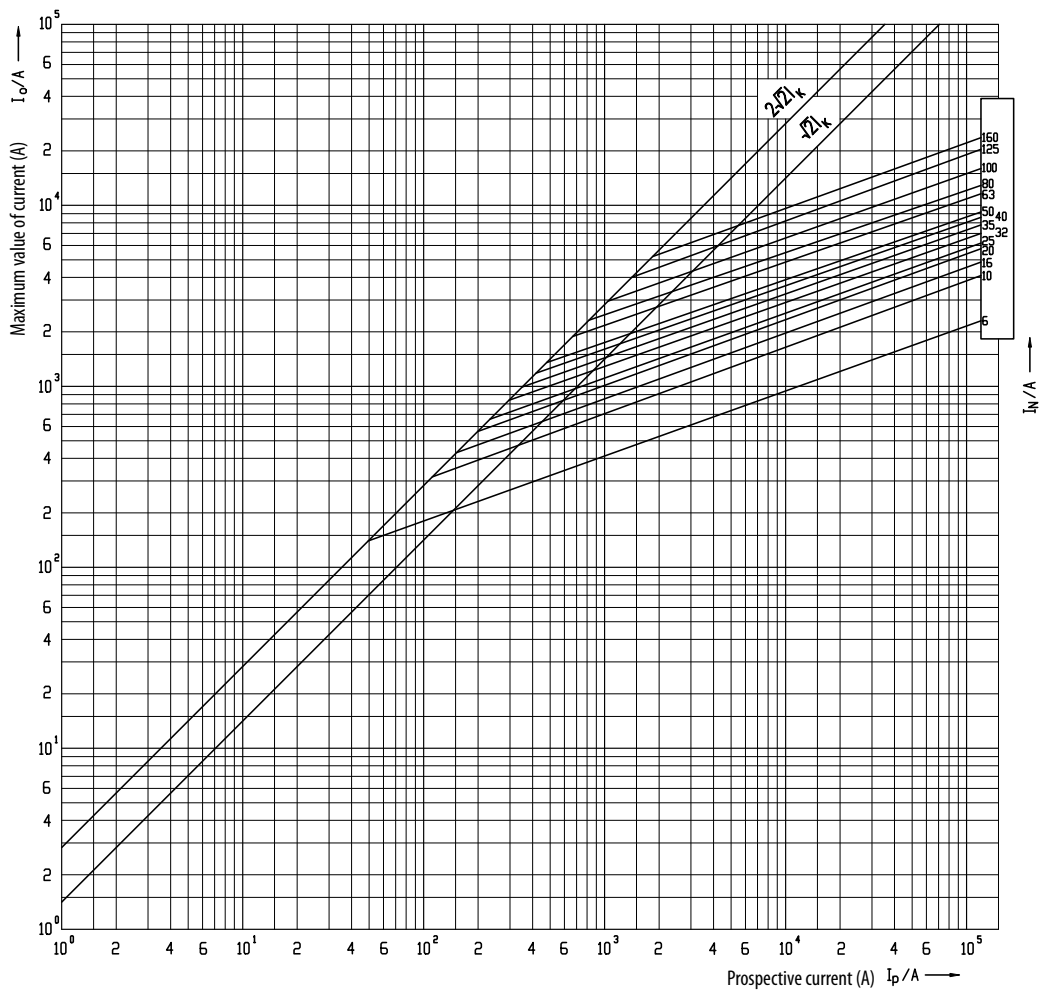

NV/NH

Technical data

NH0, NH1C
690V

Time current characteristics
I/t, gG

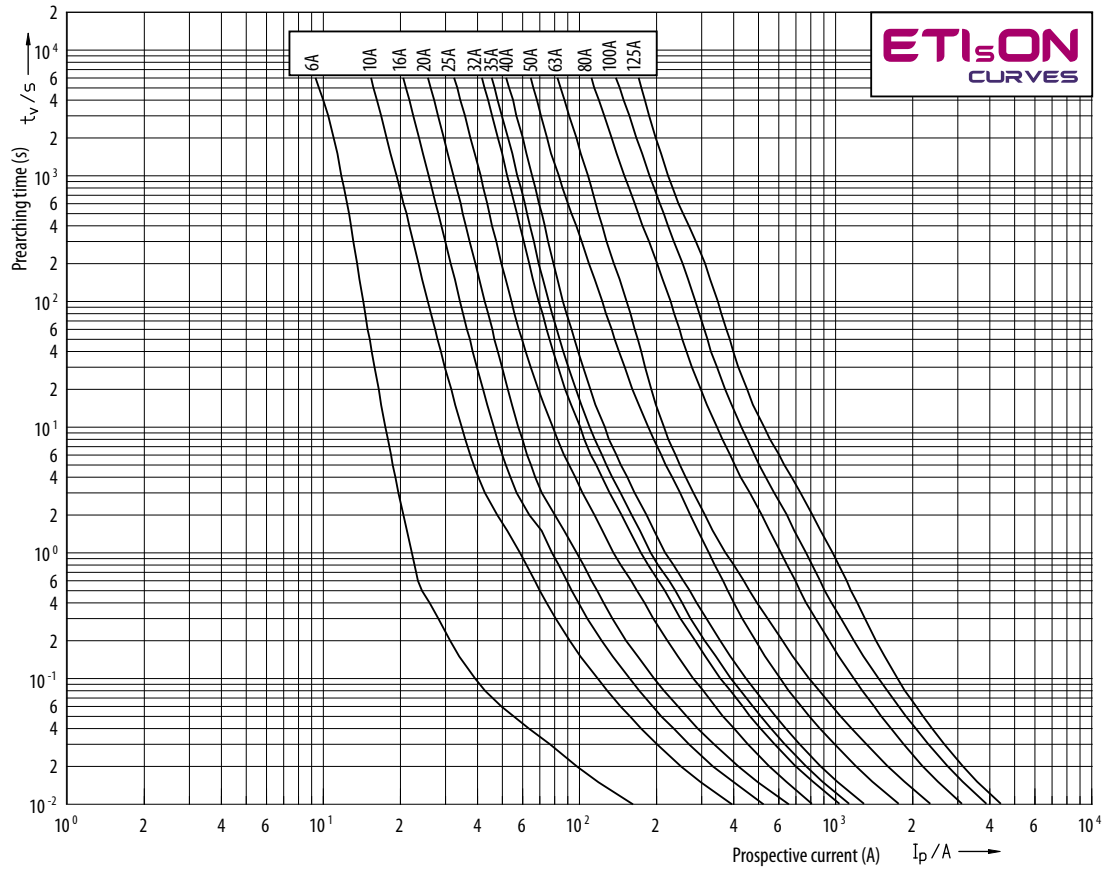

NH1 400V

Time current characteristics
I/t, gG

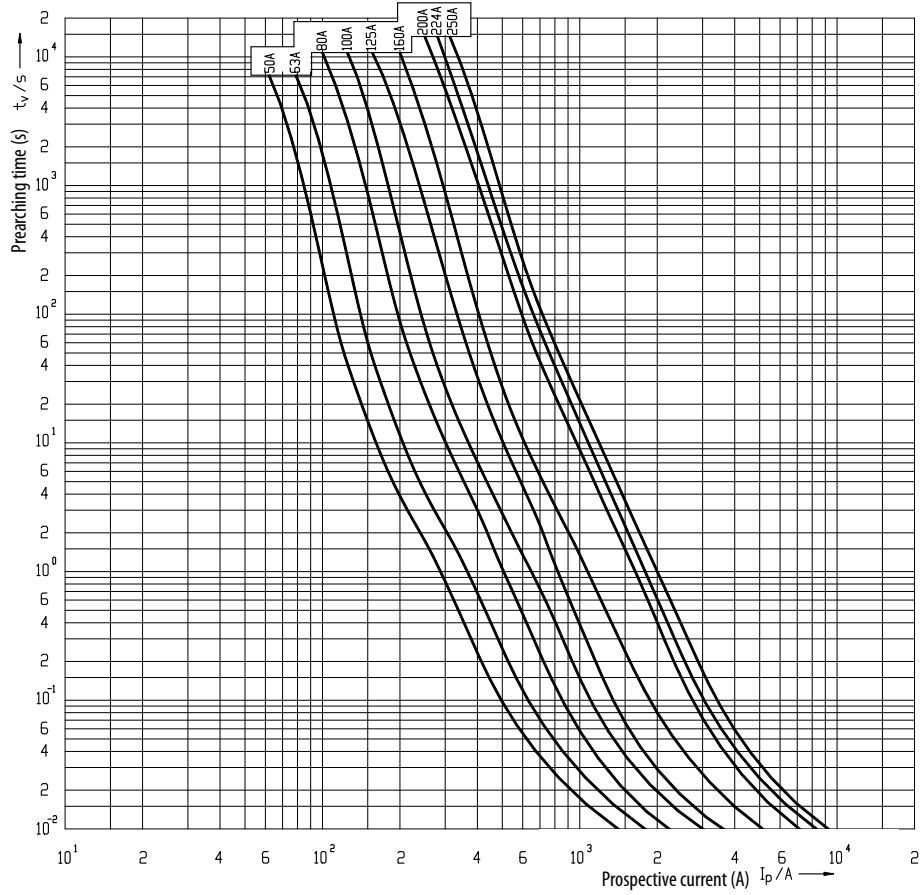

Cut-off current characteristics

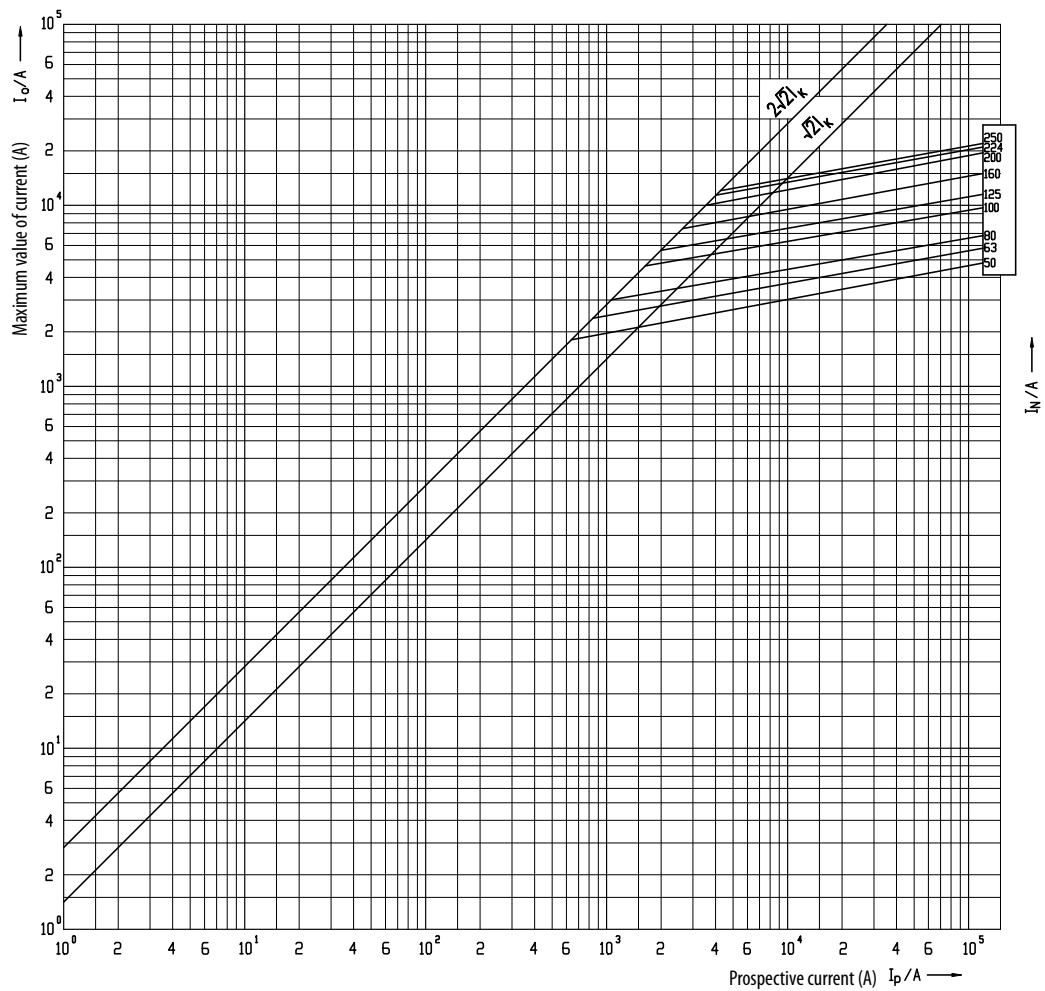

Technical data

NH1 500V

Time current characteristics
I/t, gG

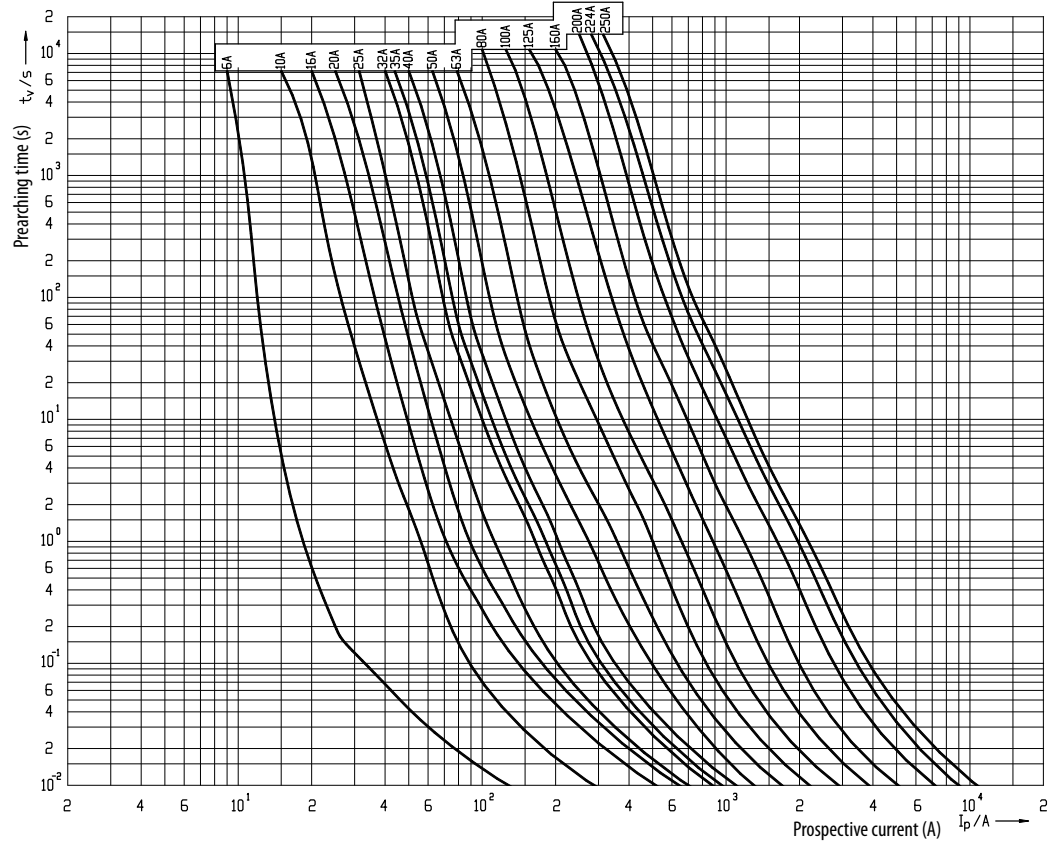

Cut-off current characteristics

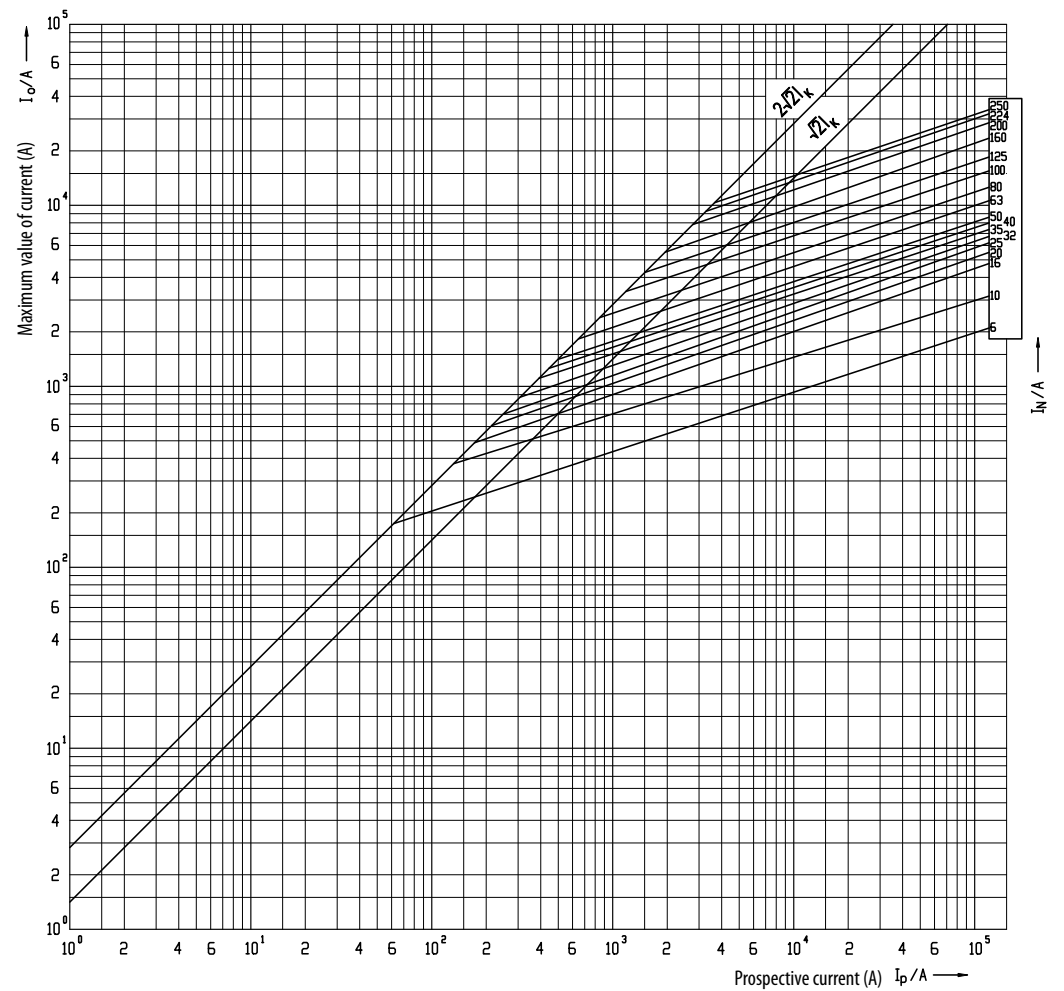

NH1 690V

Time current characteristics
I/t, gG

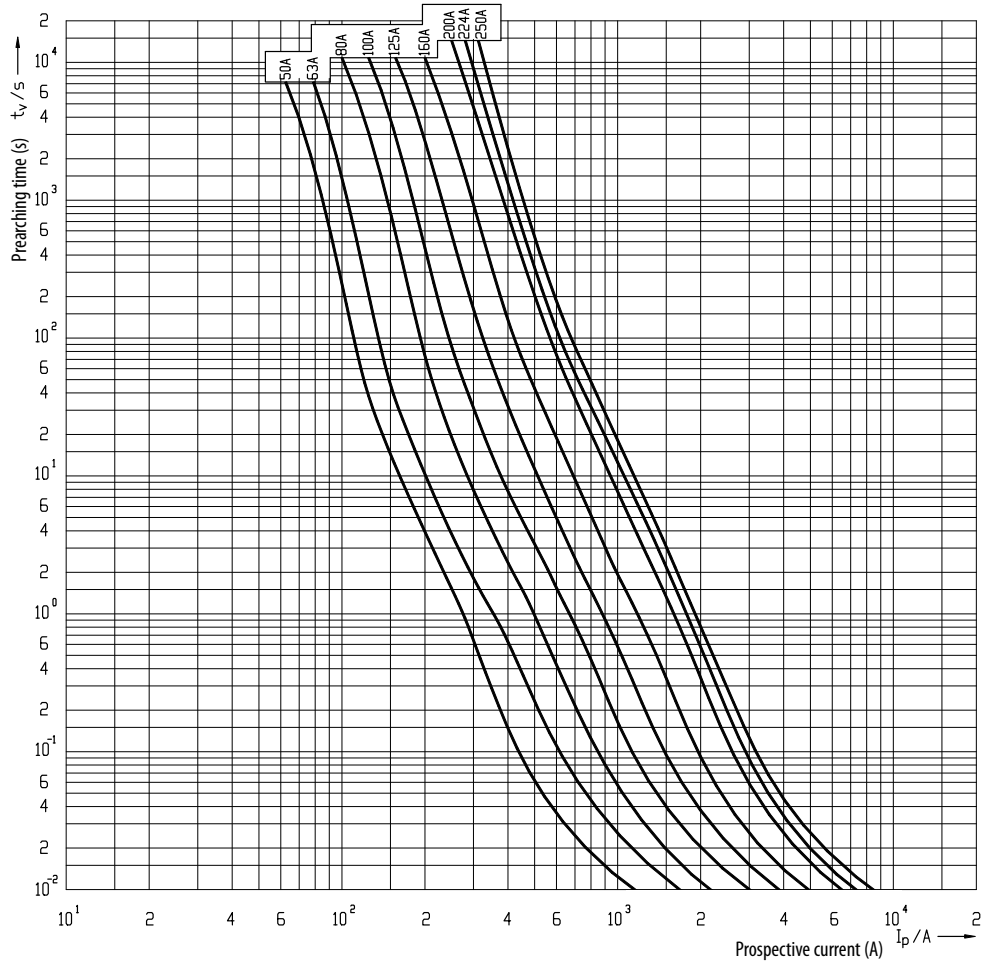

Cut-off current characteristics

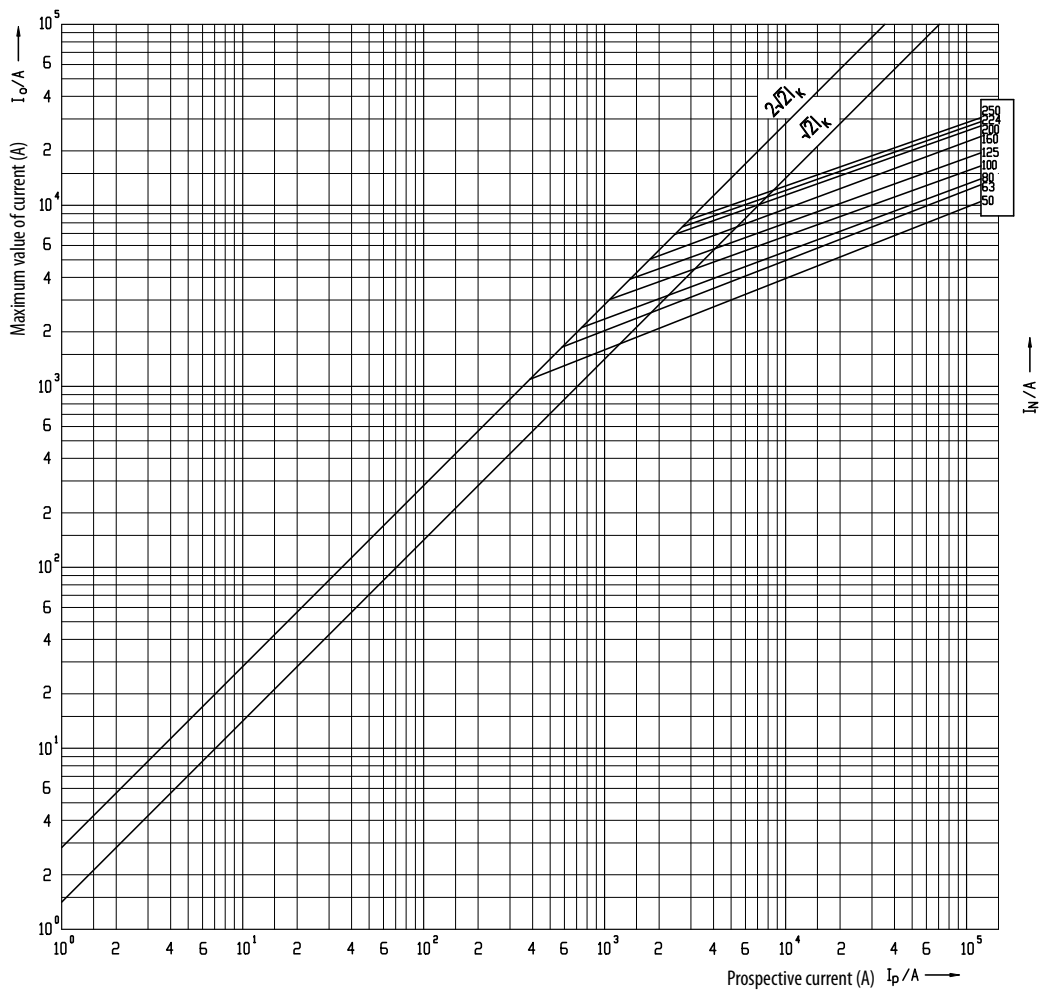

Technical data

NH2C 400V

Time current characteristics
I/t, gG

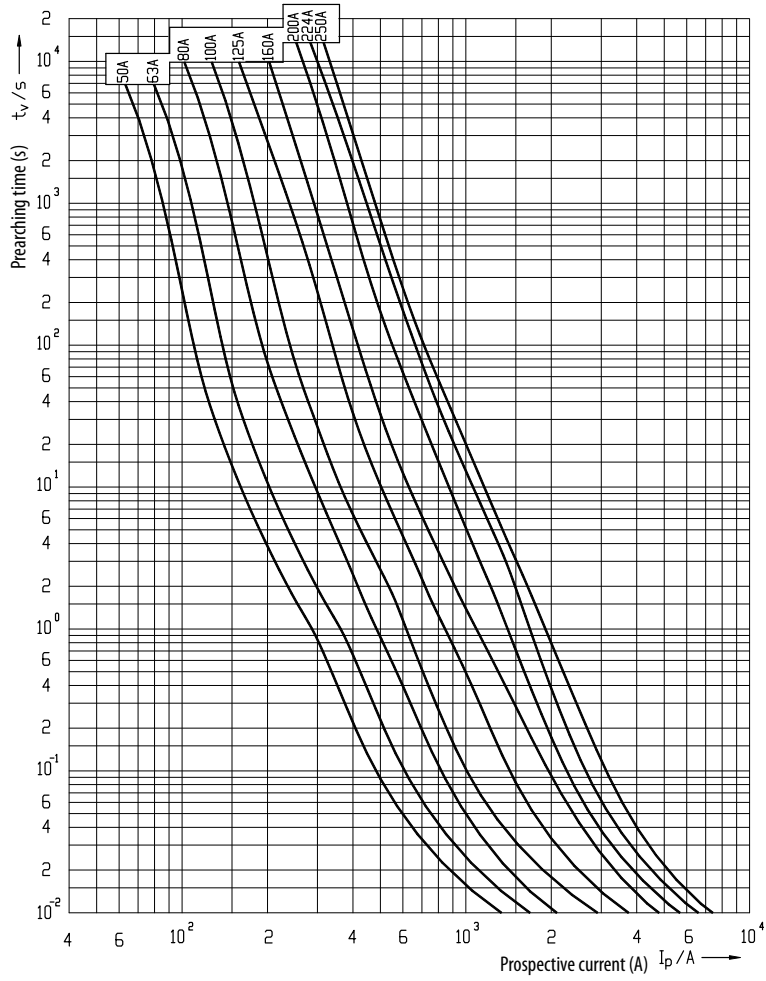

Cut-off current characteristics

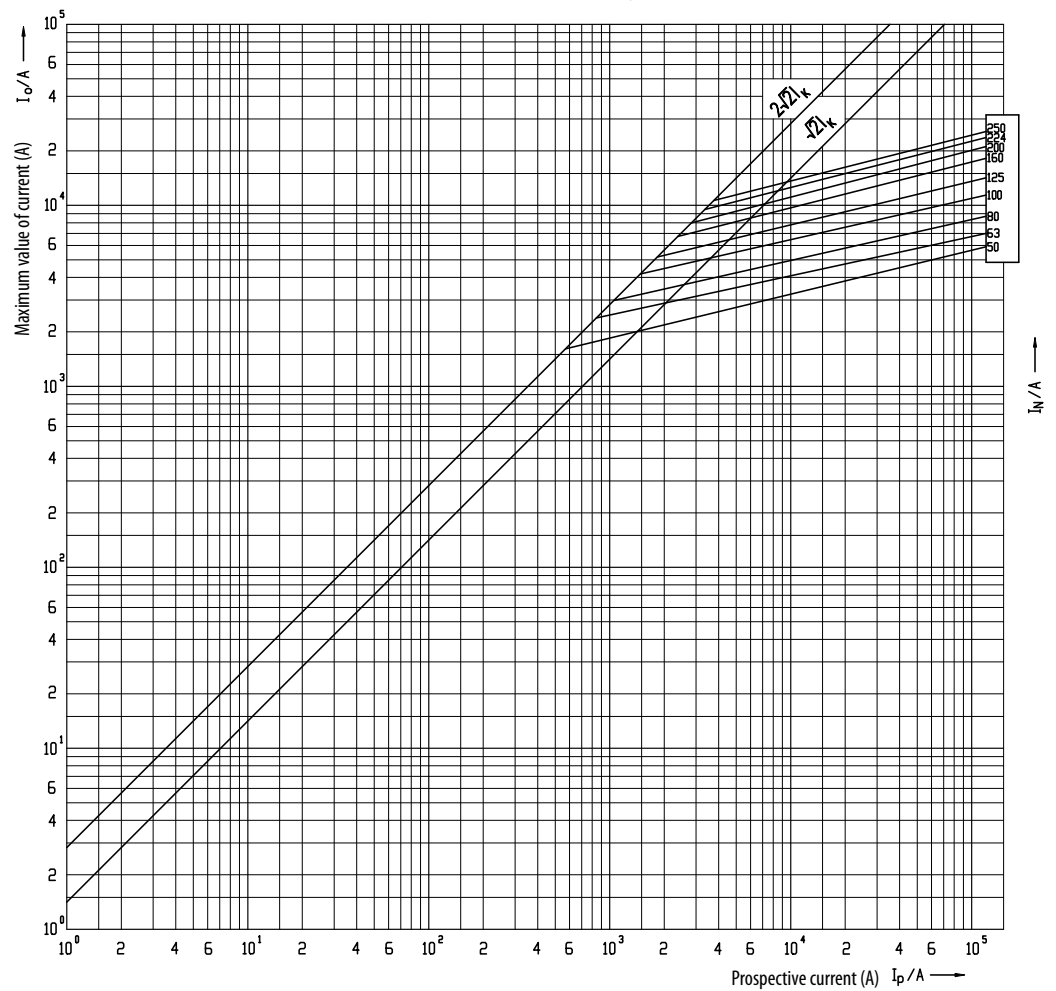

NH2C 500V

Time current characteristics
I/t, gG

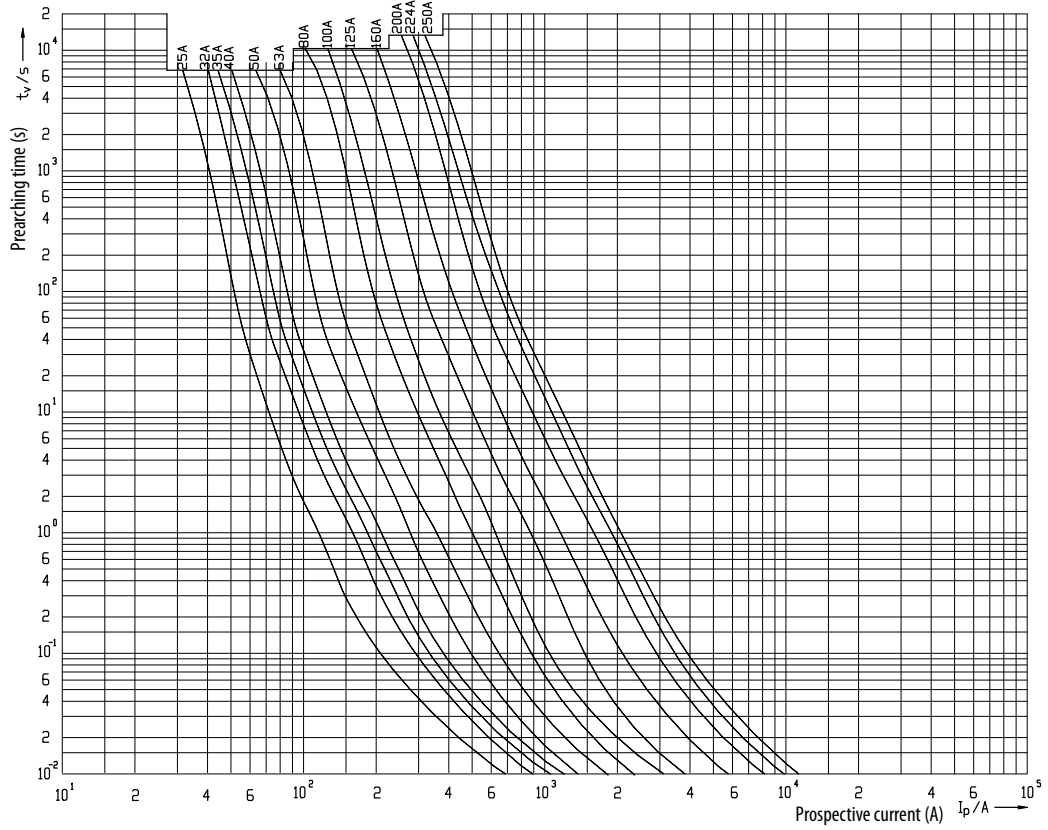

Cut-off current characteristics

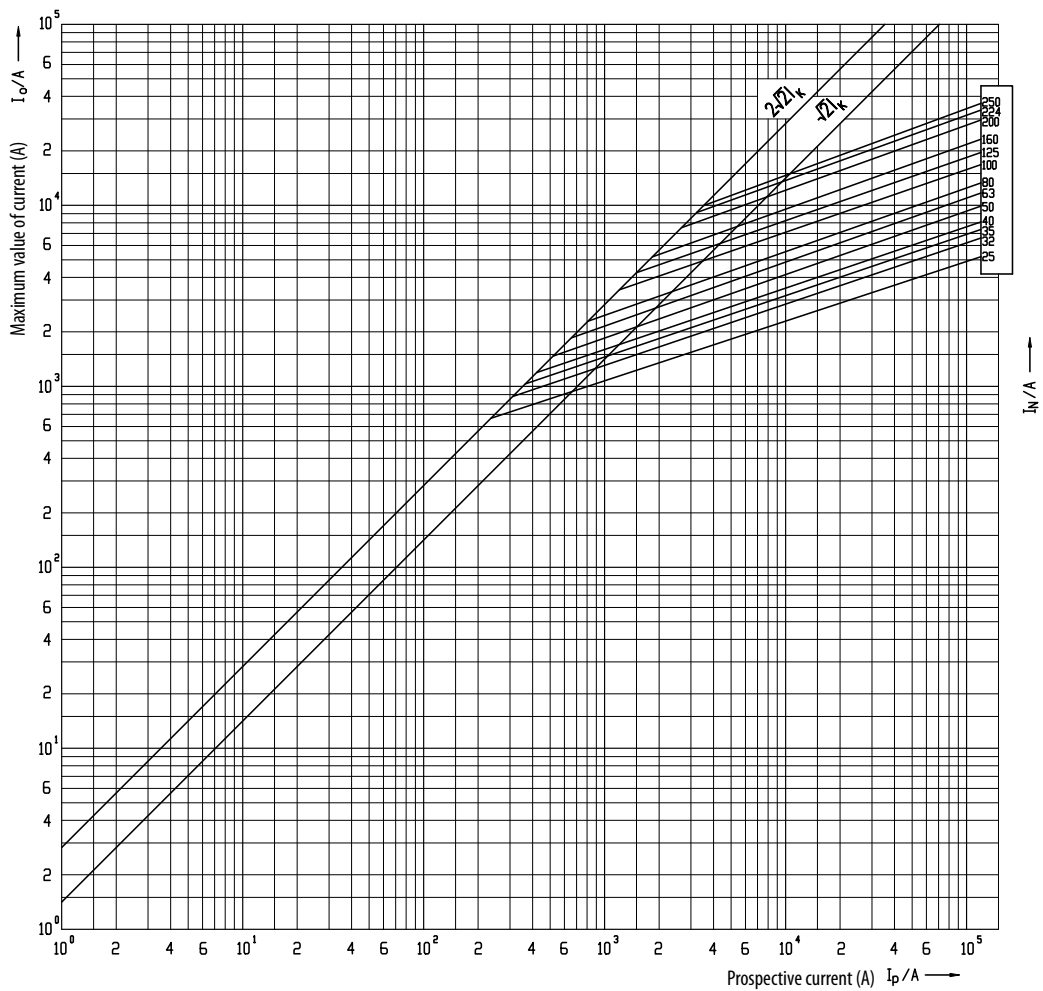

Technical data

NH2C 690V

Time current characteristics
I/t, gG

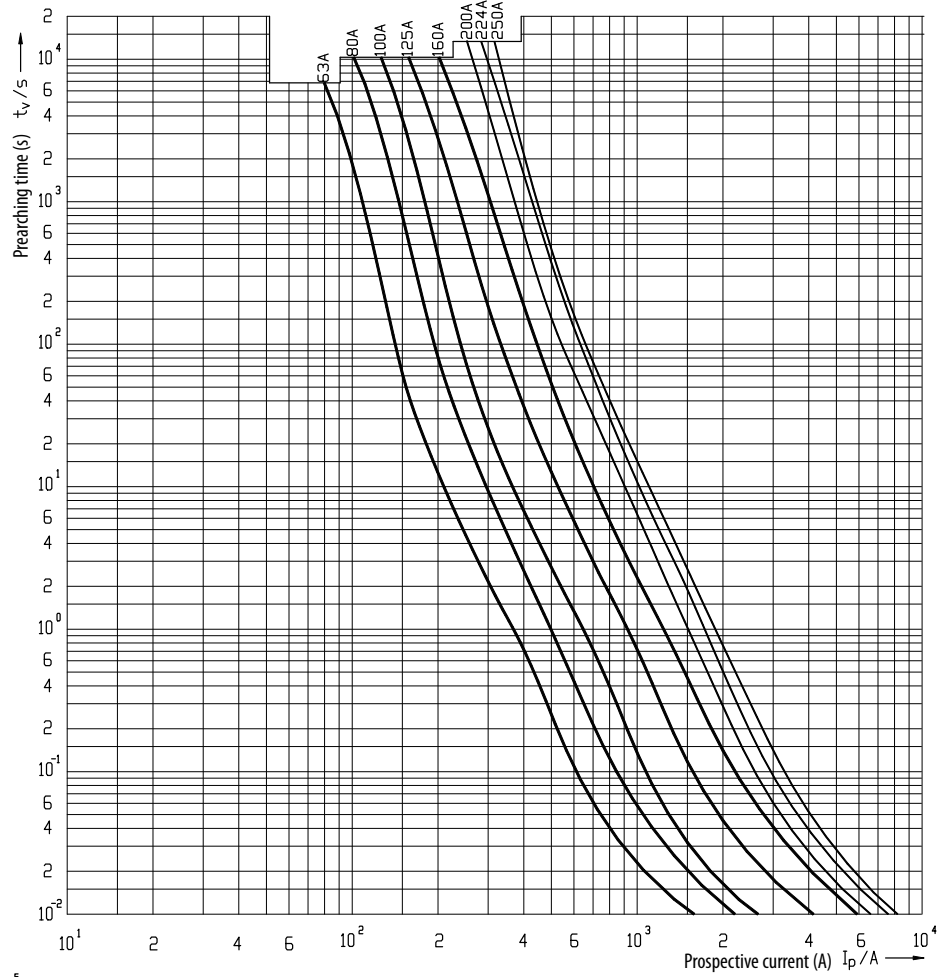

Cut-off current characteristics

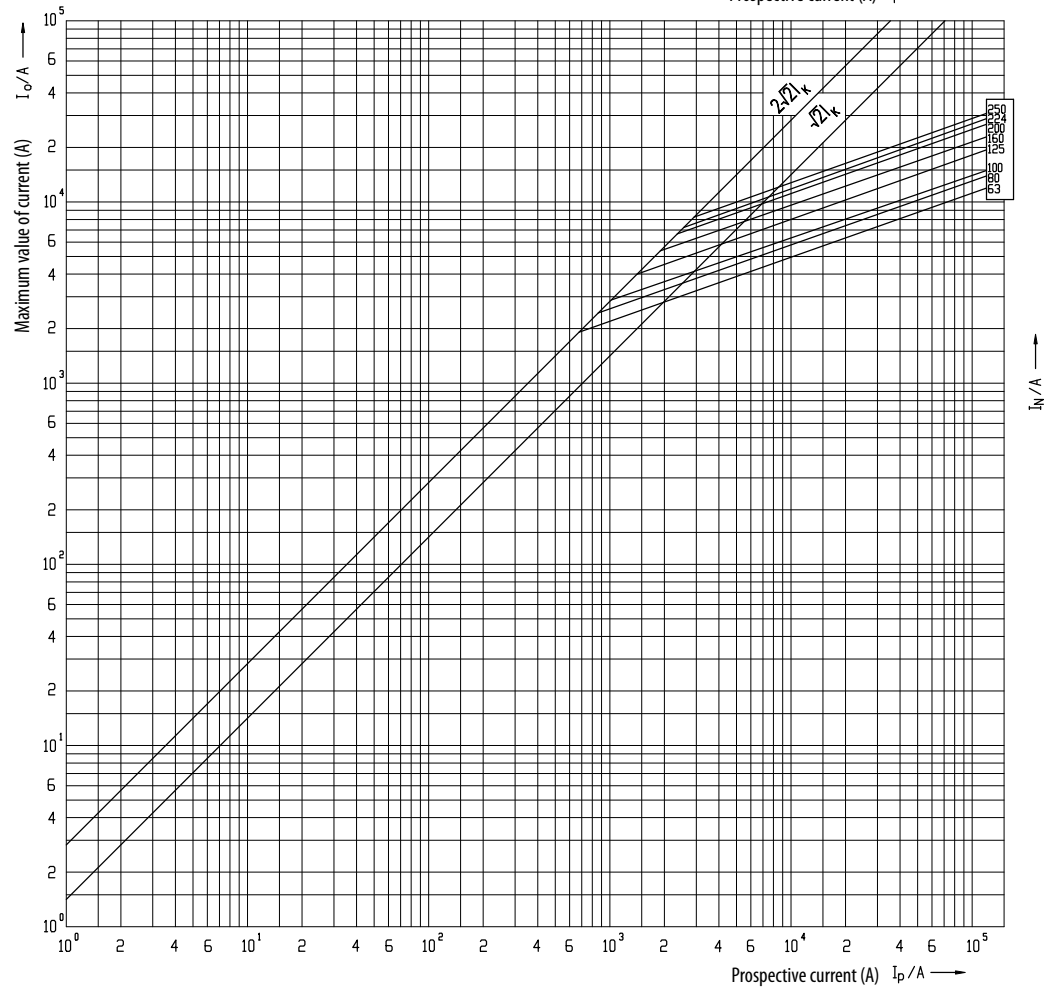

NH2 400V
Time current characteristics
I/t, gG

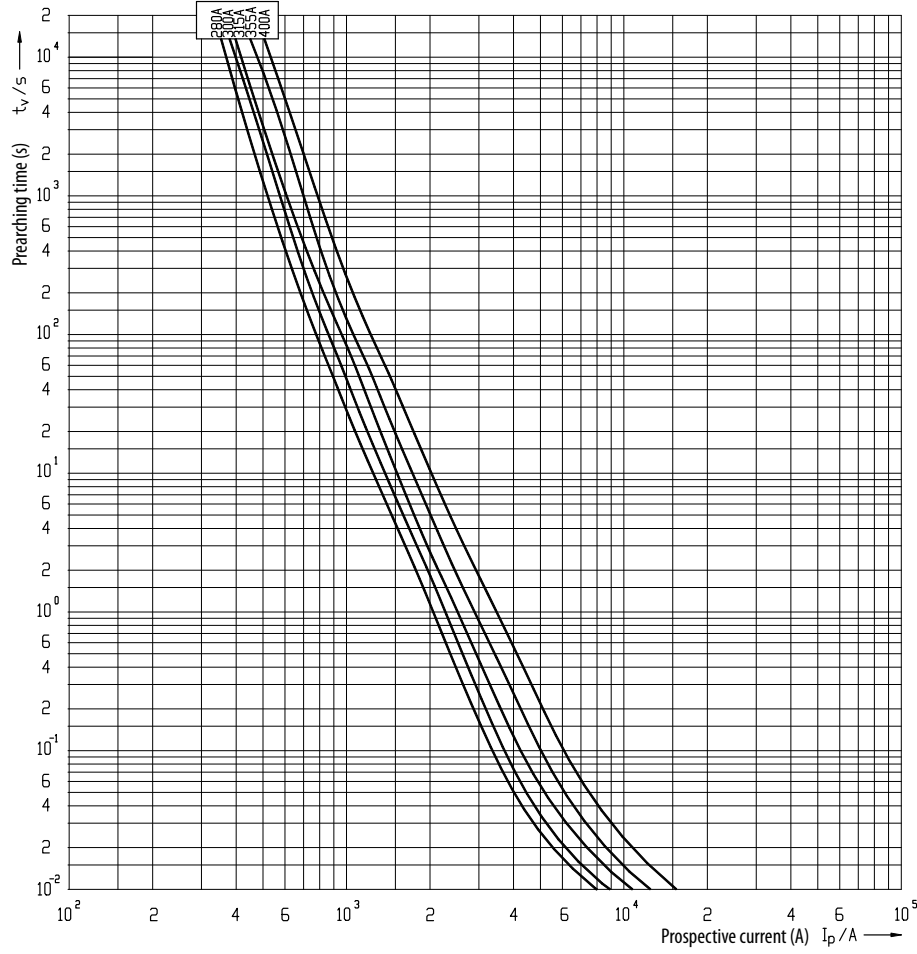

Cut-off current characteristics

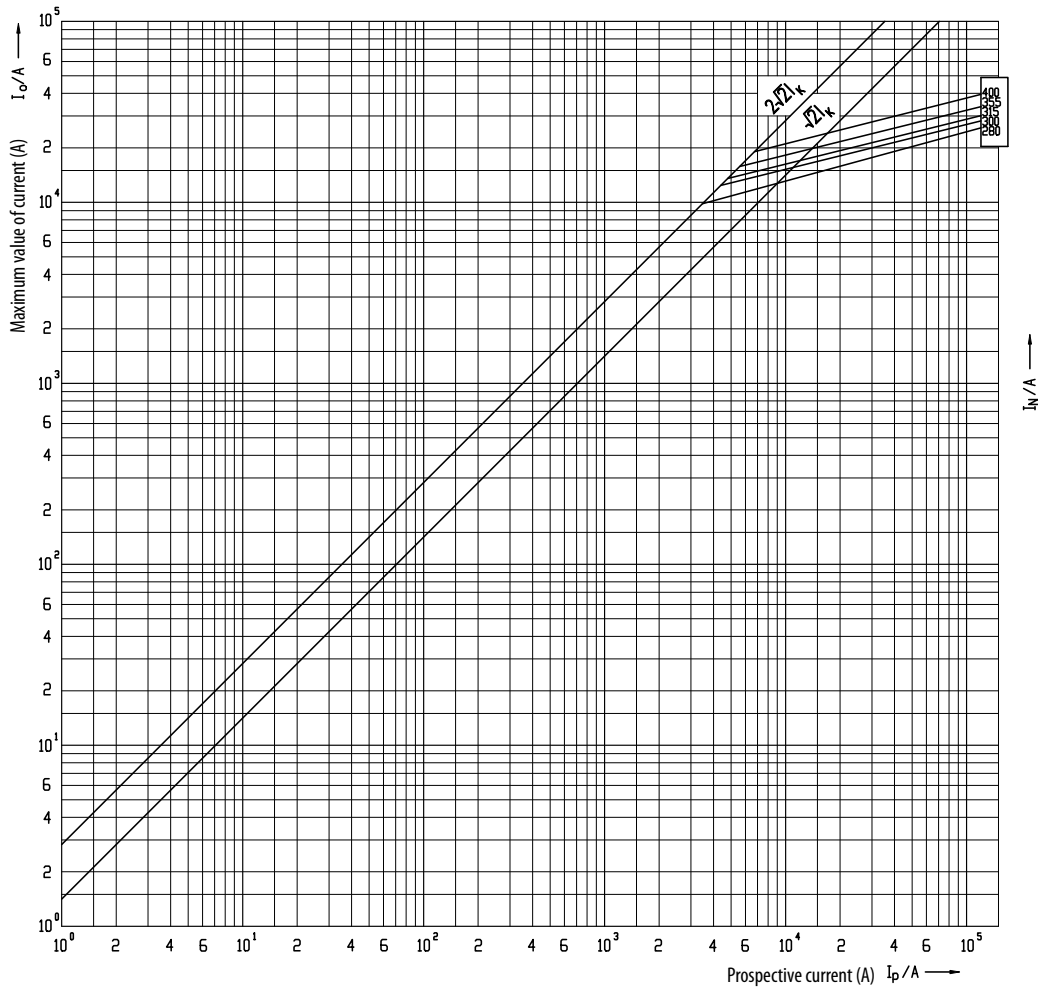

Technical data

NH2 500V

Time current characteristics
I/t, gG

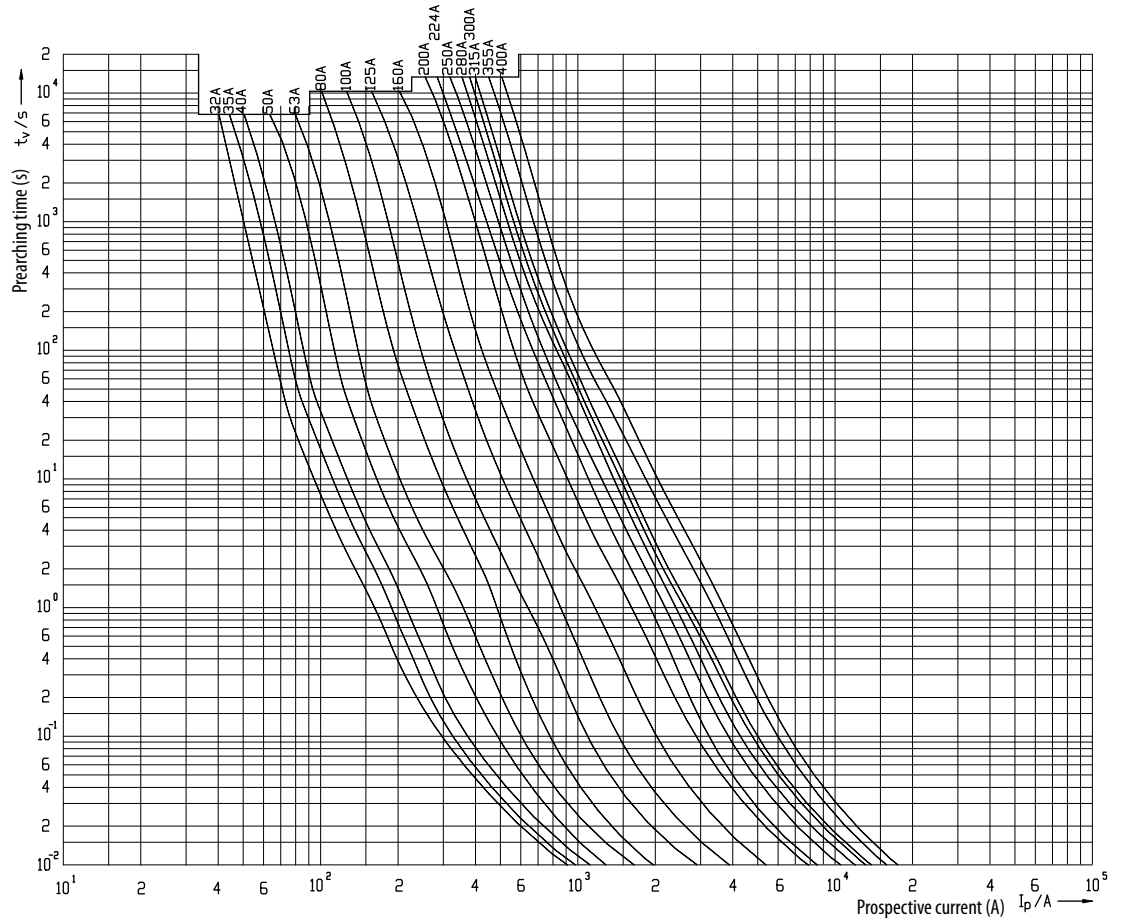

Cut-off current characteristics

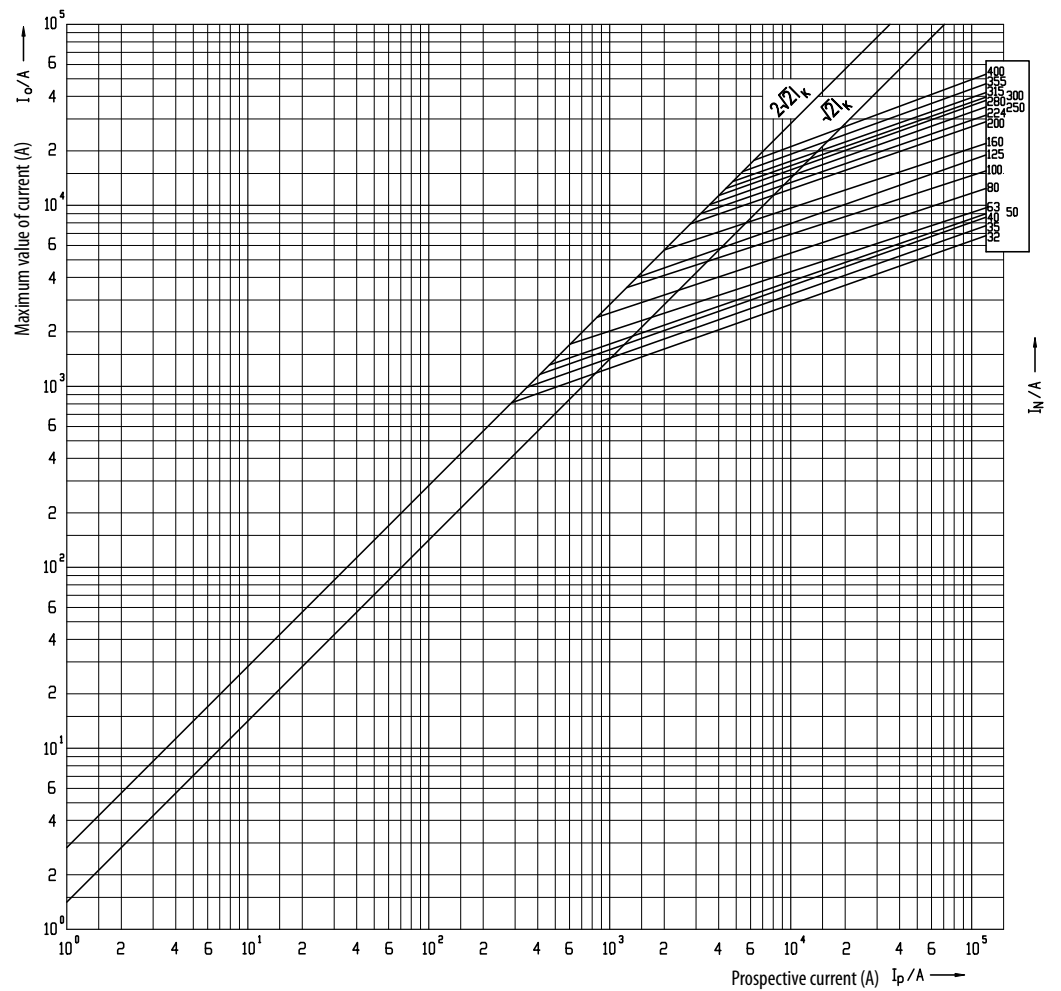

NH2 690V

Time current characteristics
I/t, gG

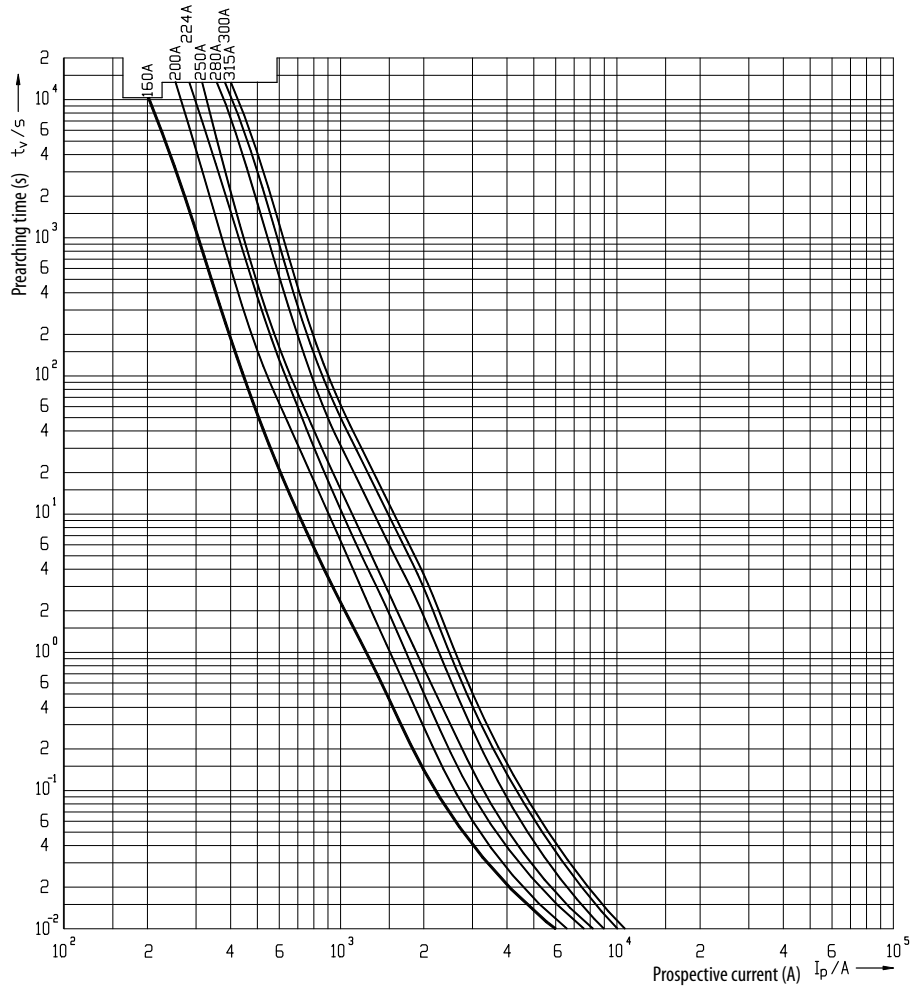

Cut-off current characteristics

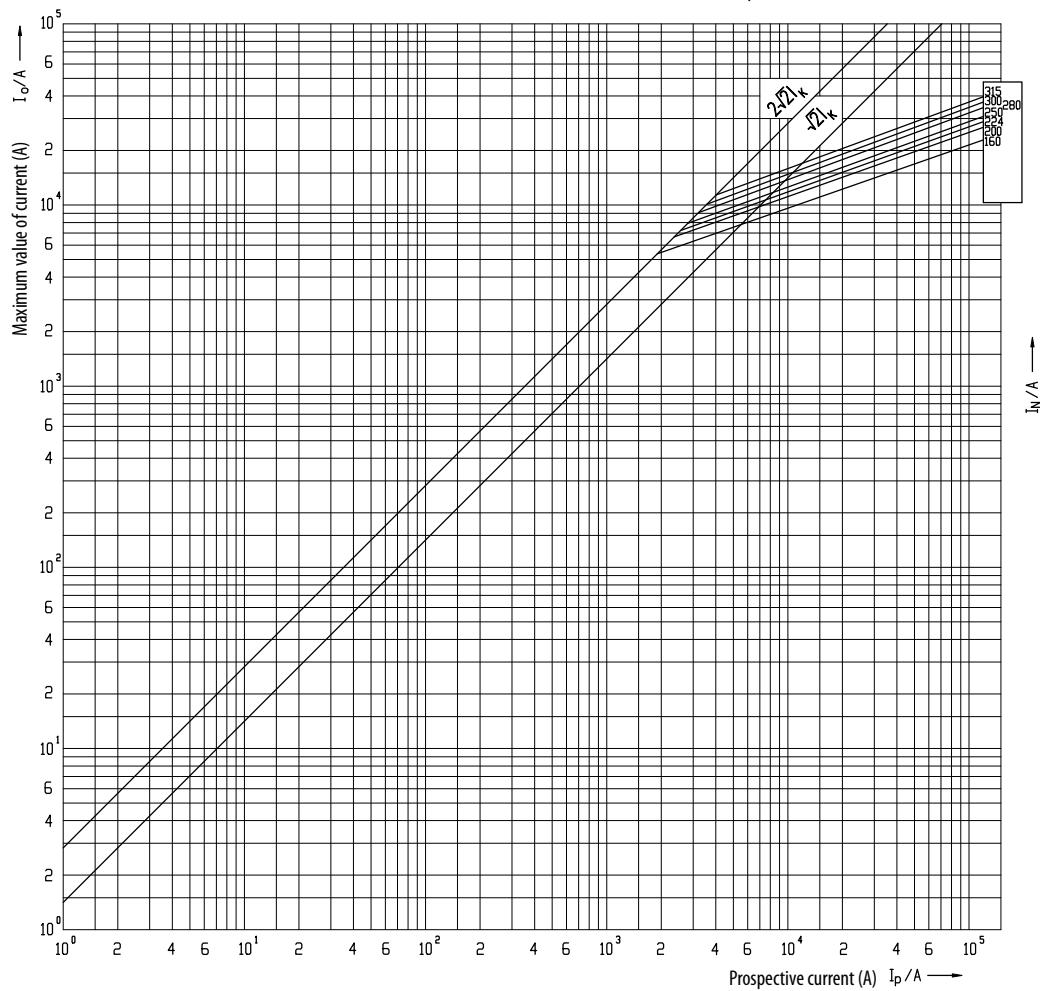

Technical data

NH3C 400V

Time current characteristics
I/t, gG

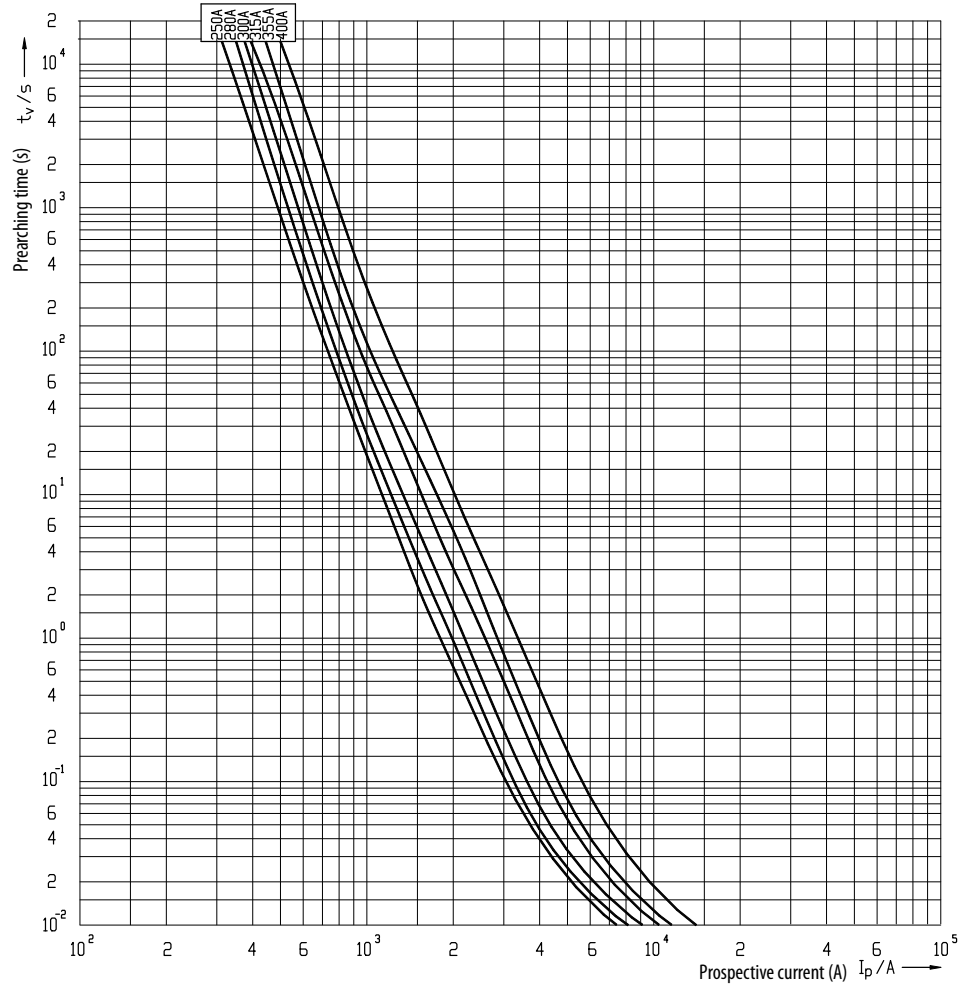

Cut-off current characteristics

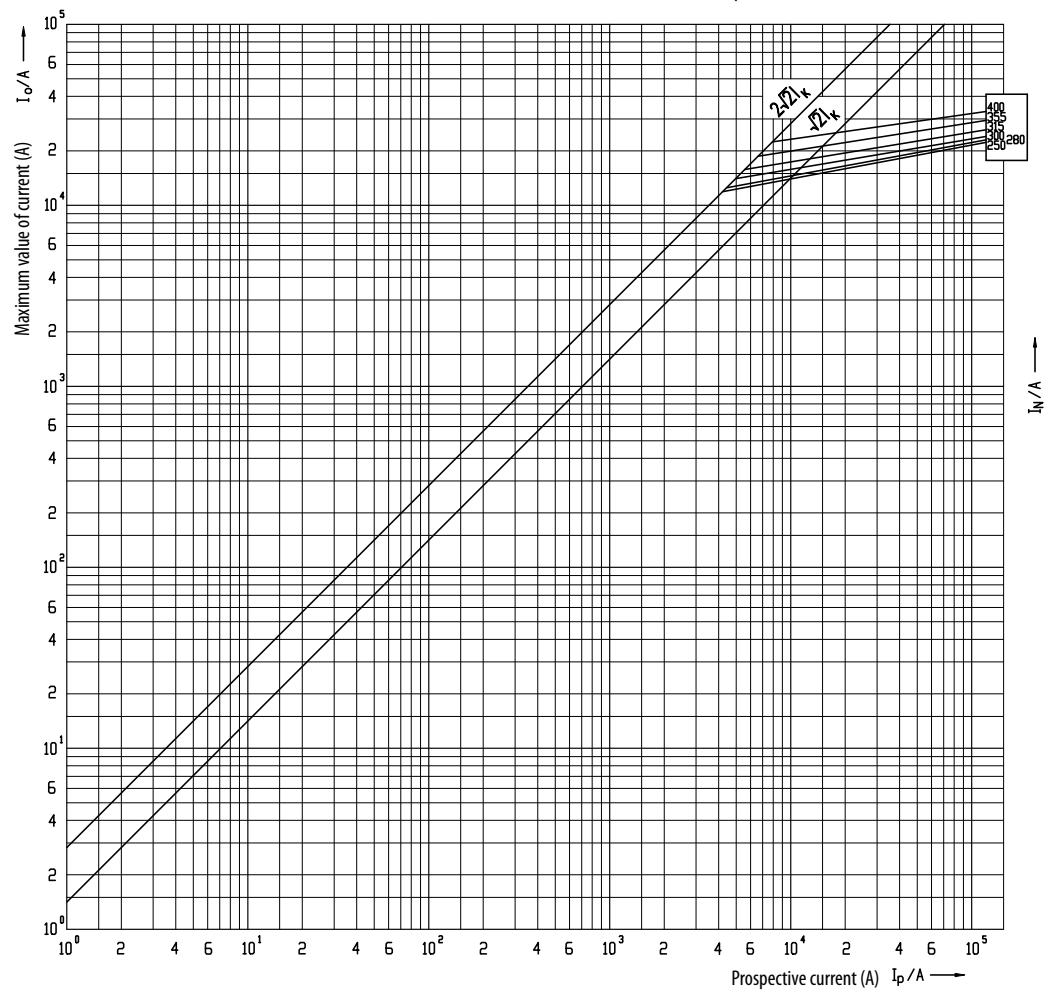

NH3C 500V

Time current characteristics
I/t, gG

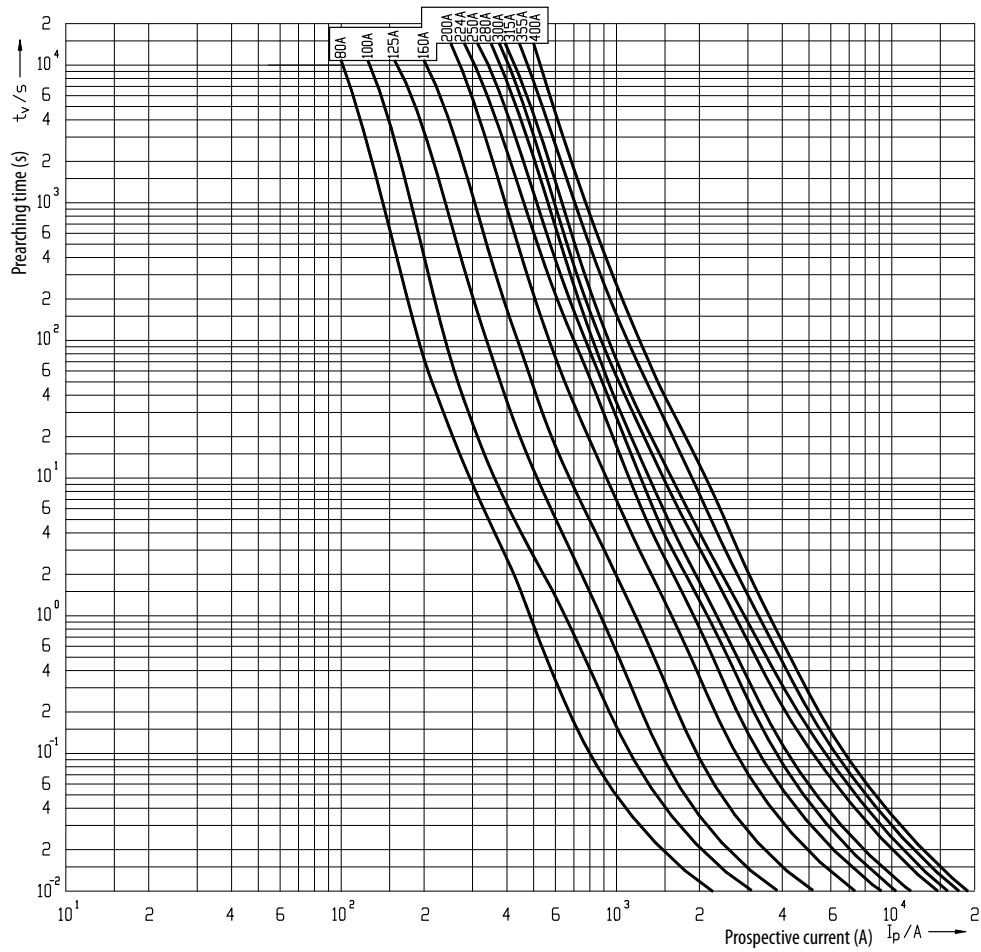

Cut-off current characteristics

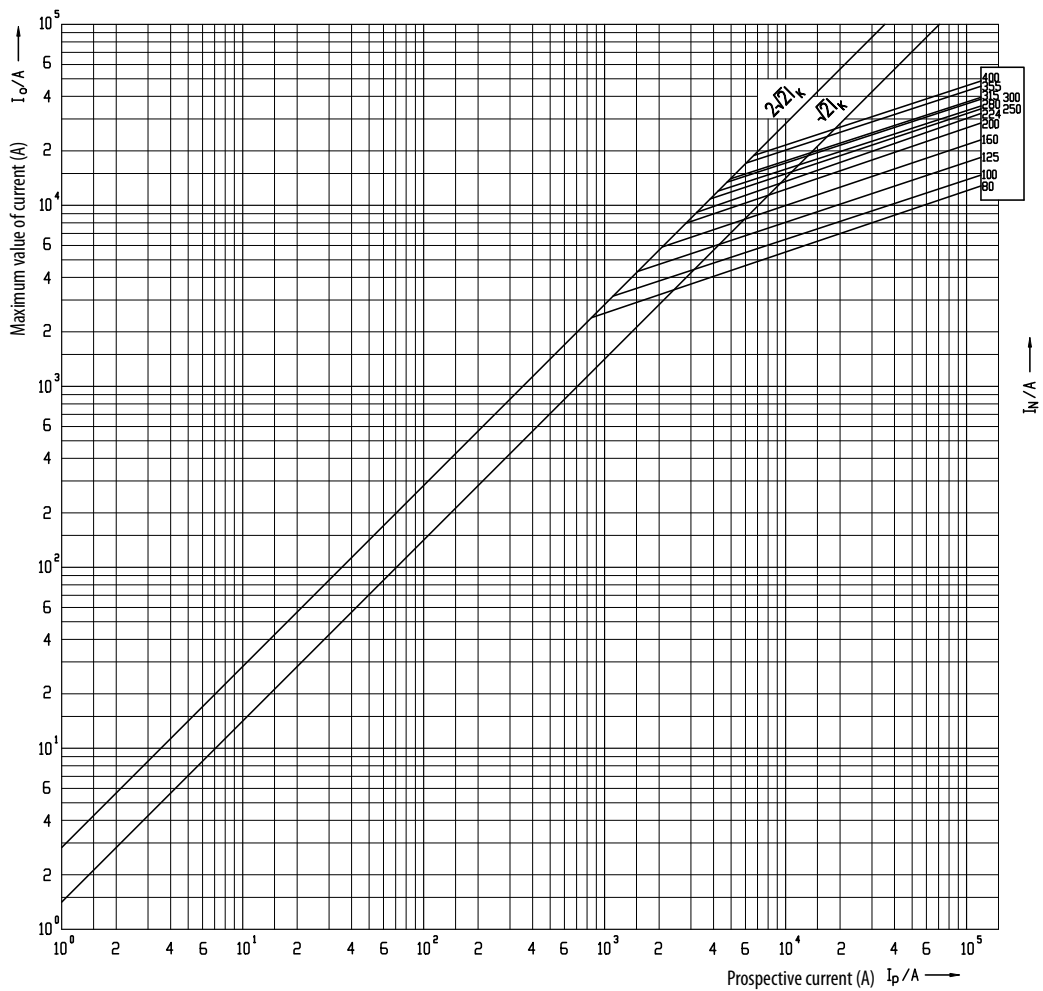

Technical data

NH3C 690V

Time current characteristics
I/t, gG

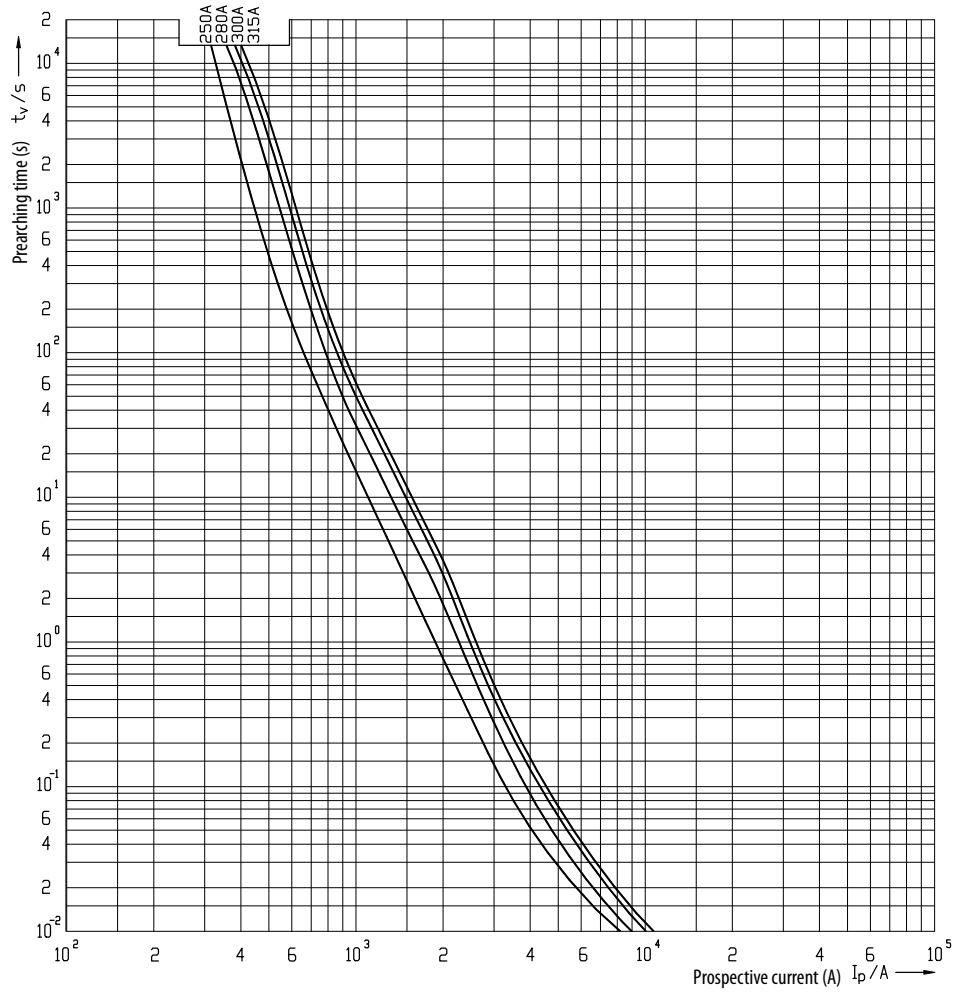

Cut-off current characteristics

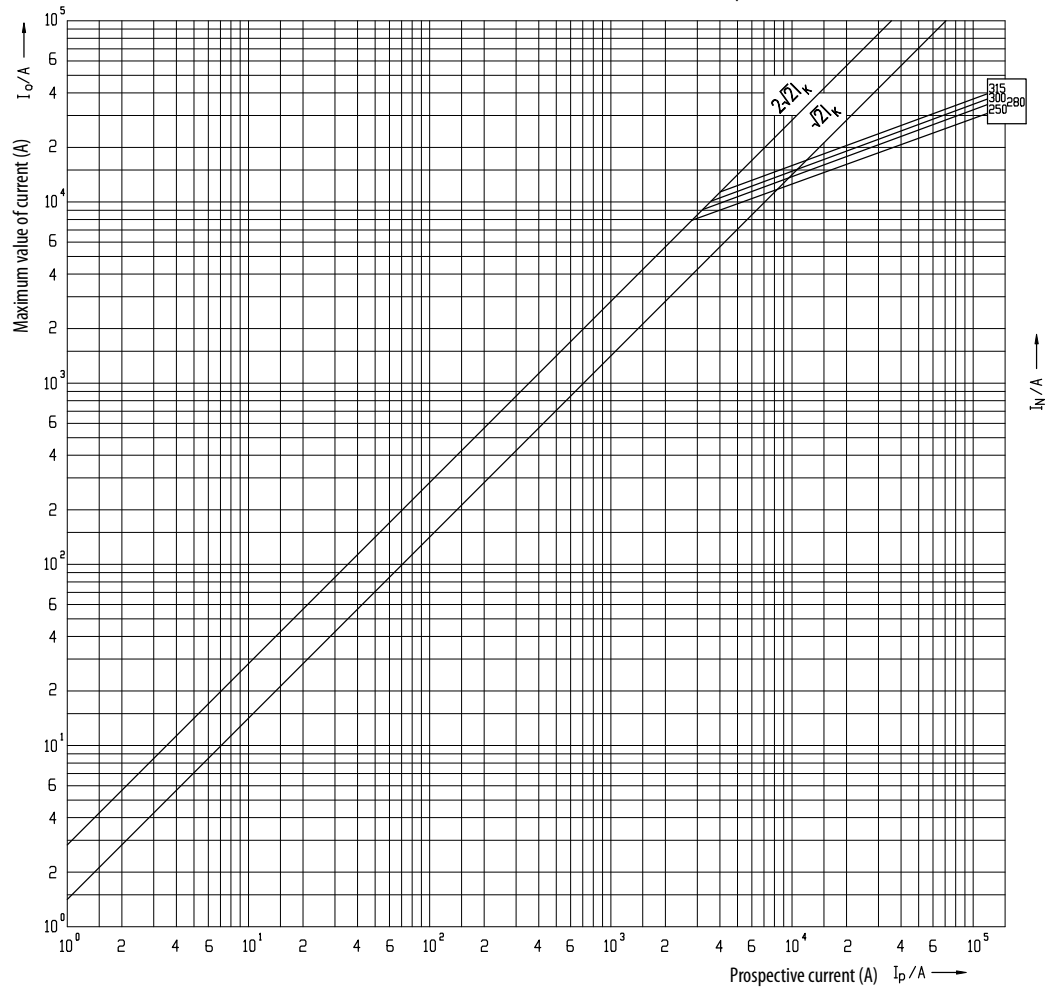

NH3 400V

Time current characteristics
I/t, gG

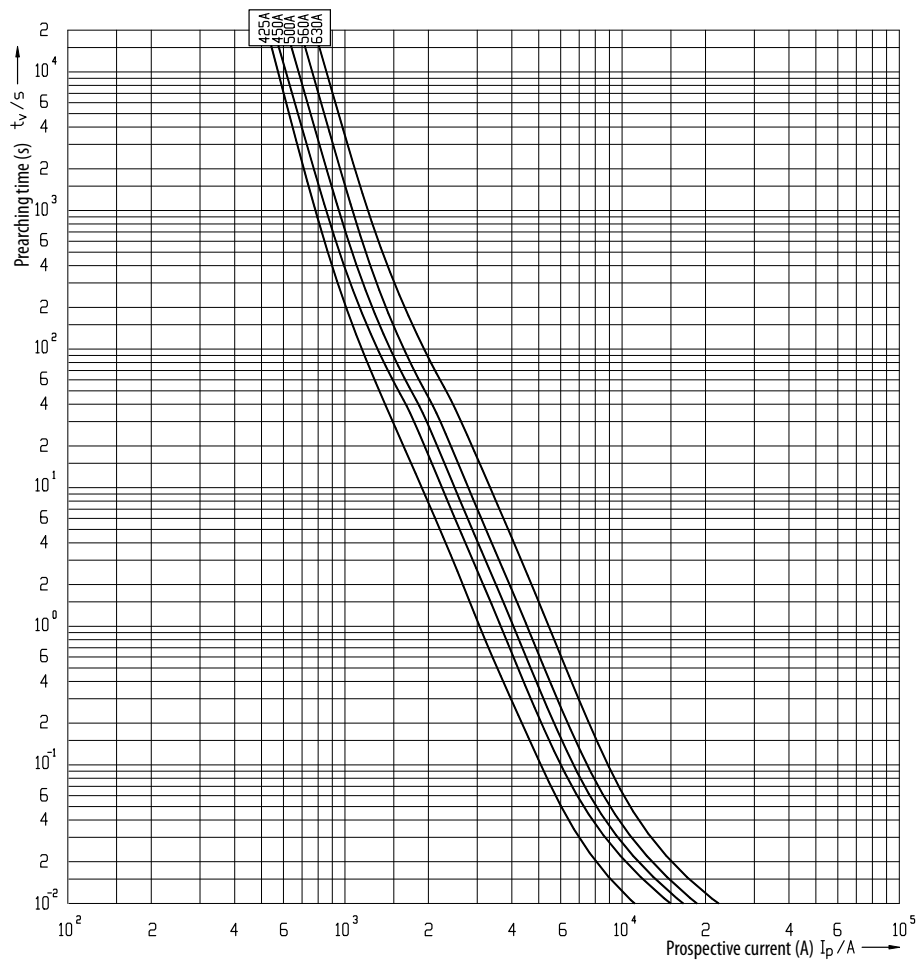
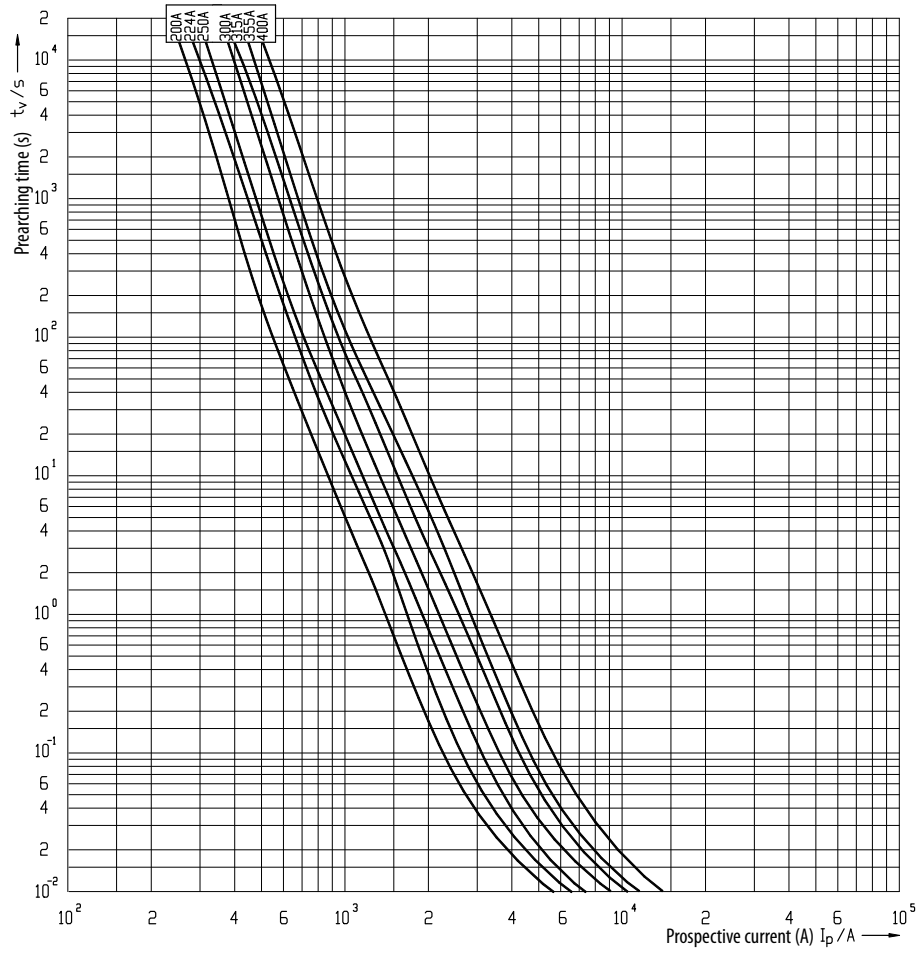

Technical data

Cut-off current characteristics

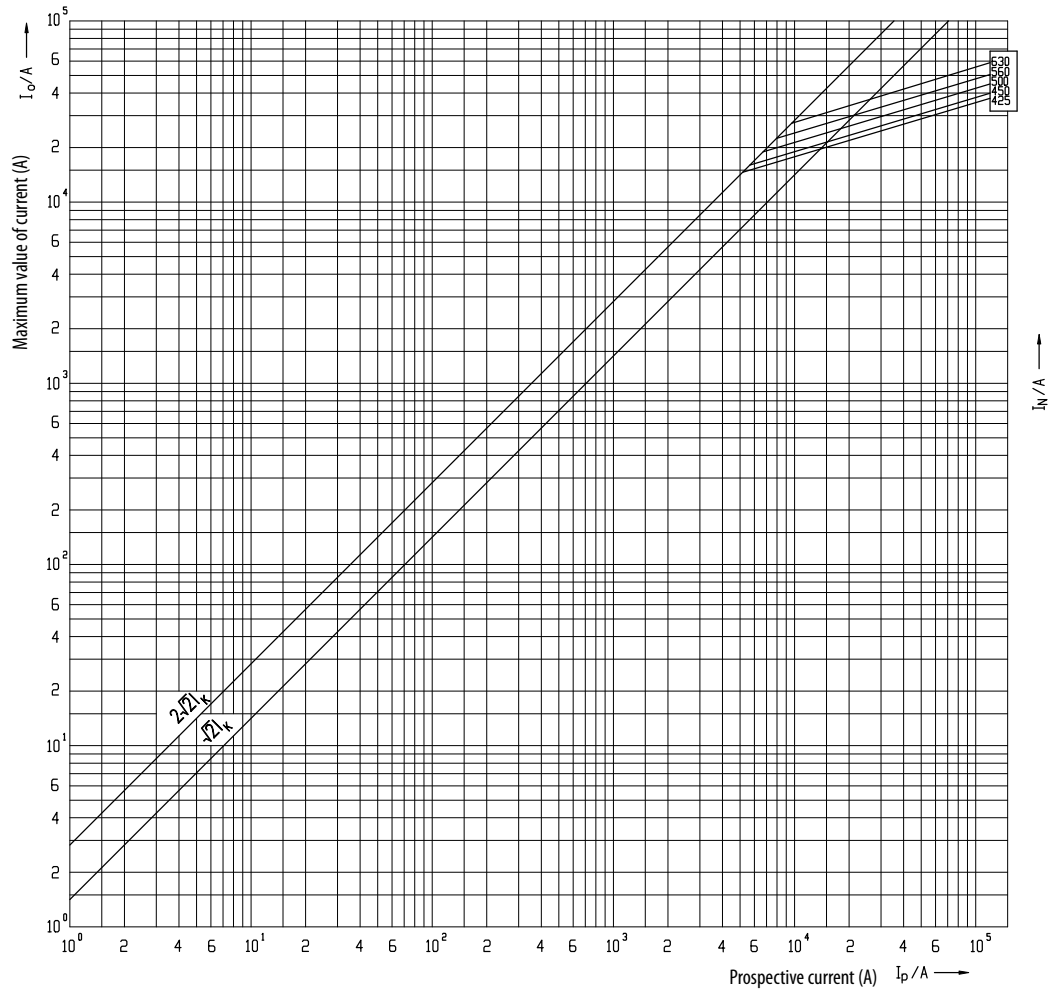

NH3 500V

Time current characteristics
I/t, gG

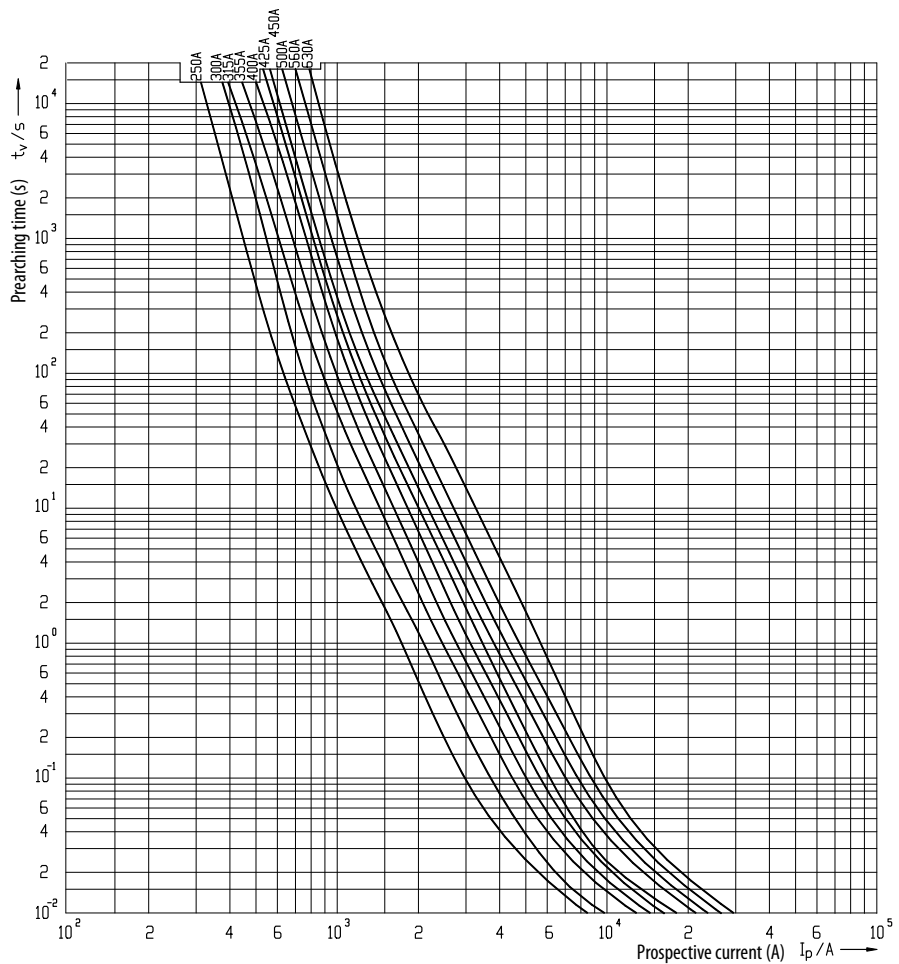
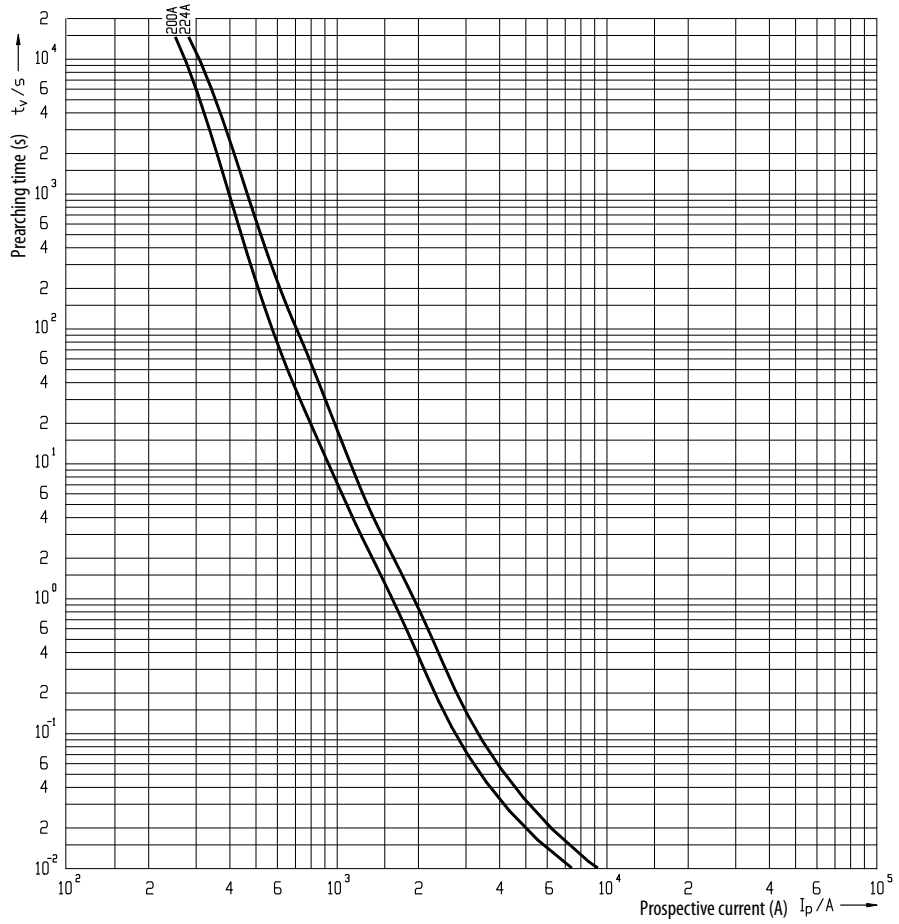

Technical data

Cut-off current characteristics

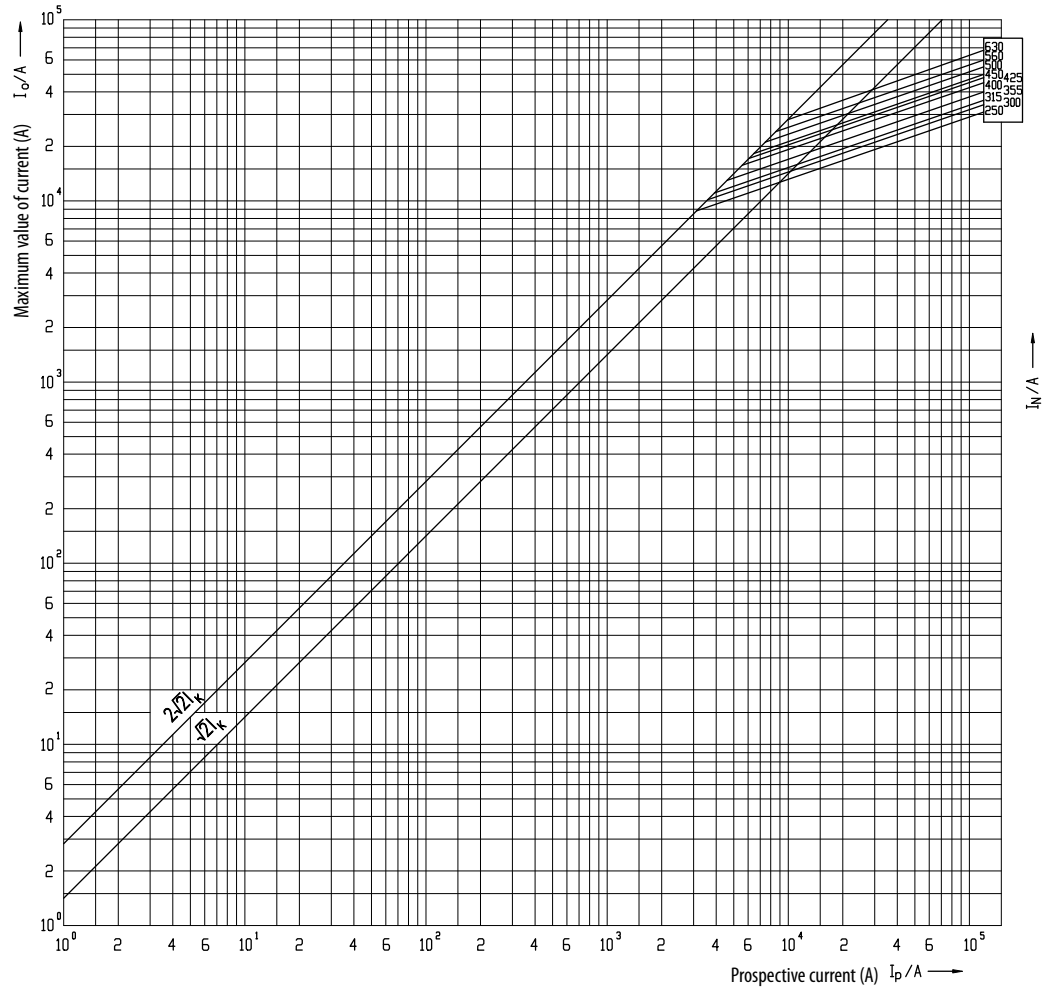

NH3 690V

Time current characteristics
I/t, gG

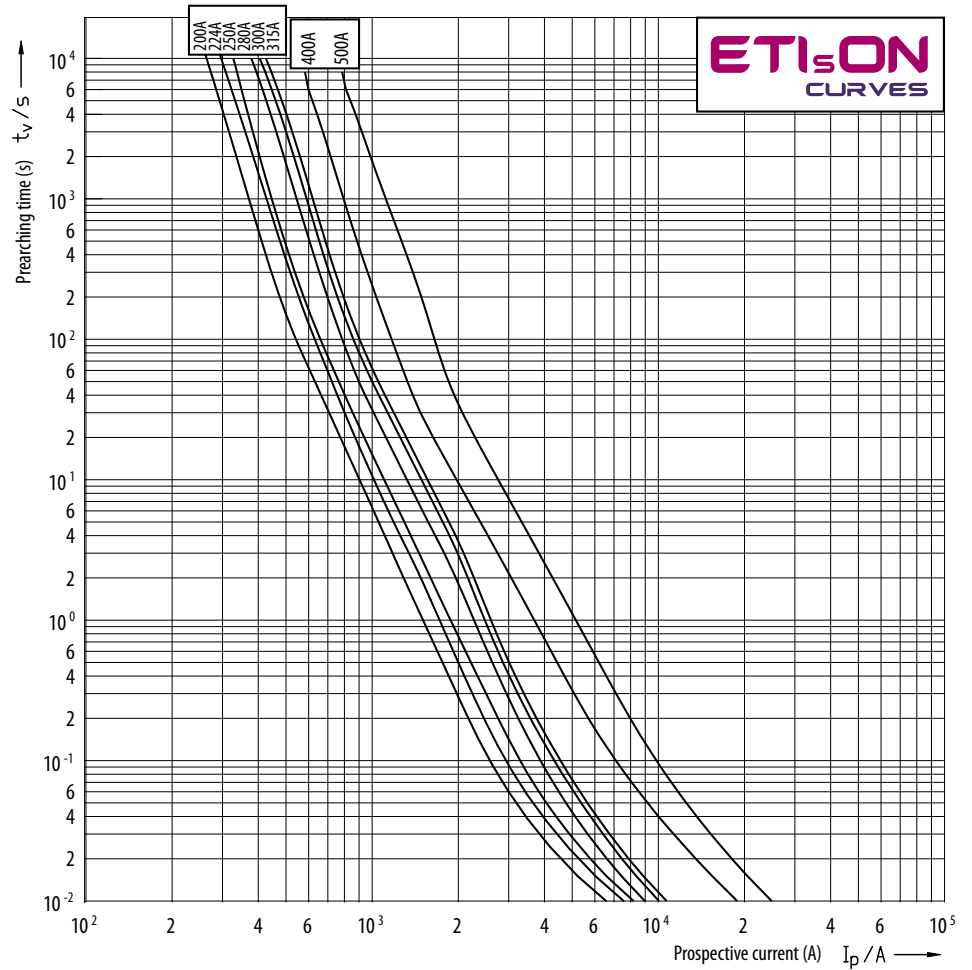

NH4

Time current characteristics
I/t, gG

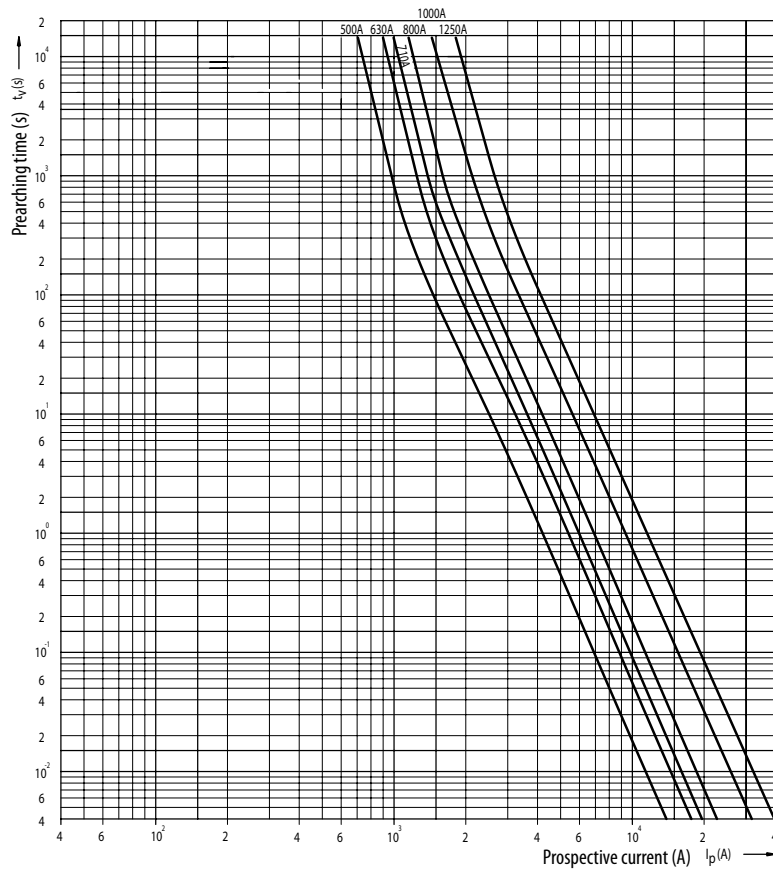

NH4a

Time current characteristics I/t, gG
(nonstandard rated currents)

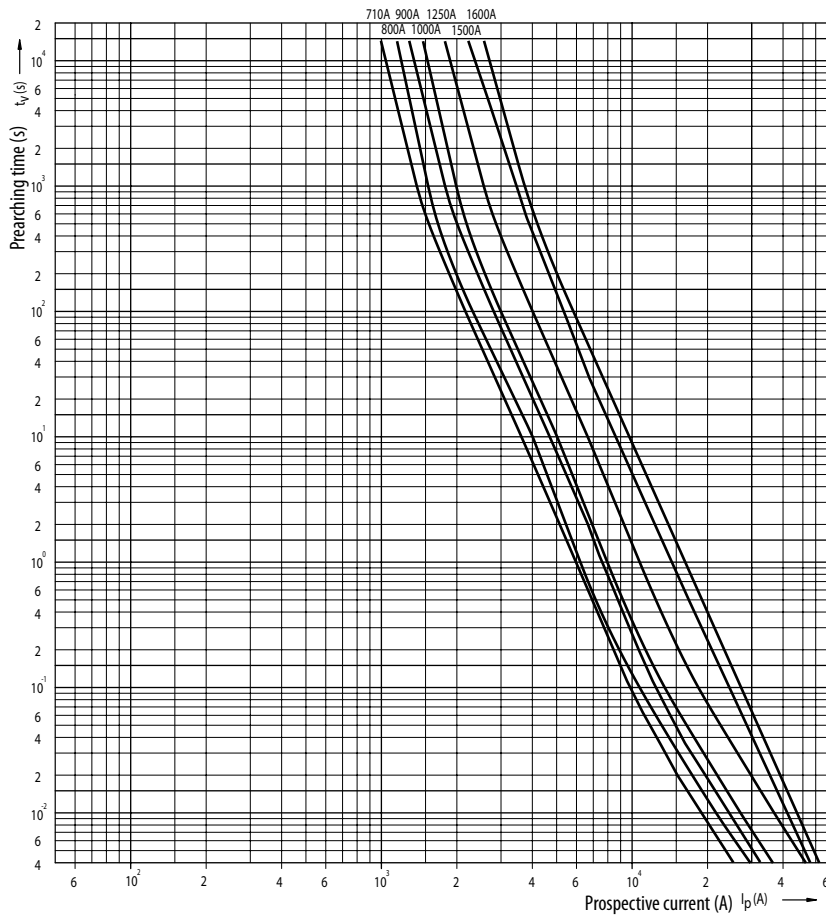

NH/NH

Technical data

NH1 1000V

Time current characteristics
I/t, gG

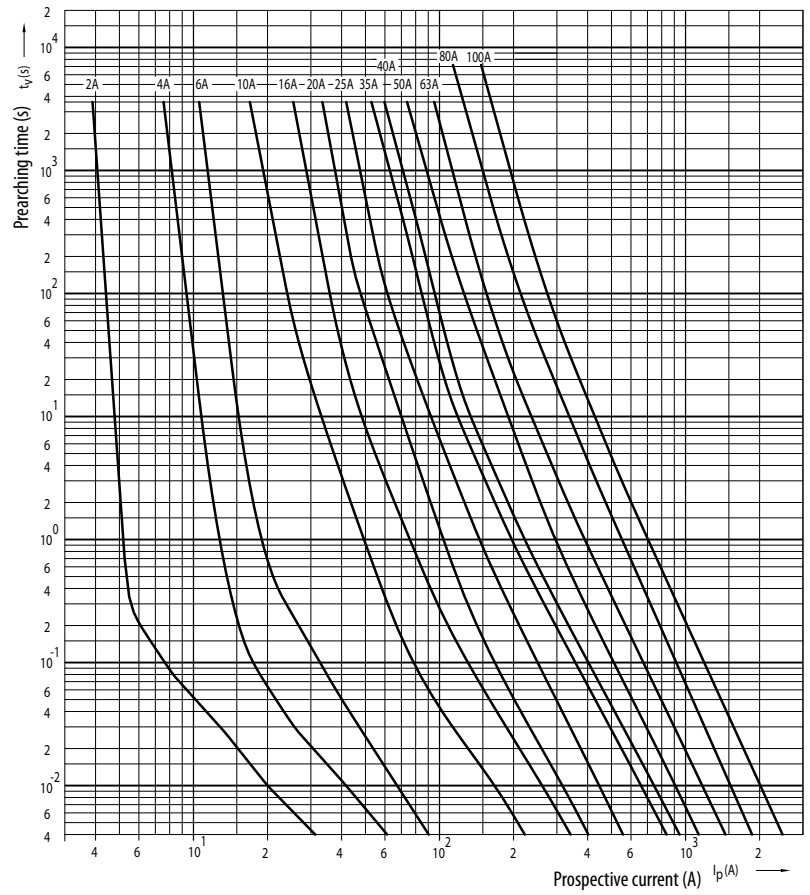

**NH4
NH4a
NH1 1000V**

Cut-off current characteristics

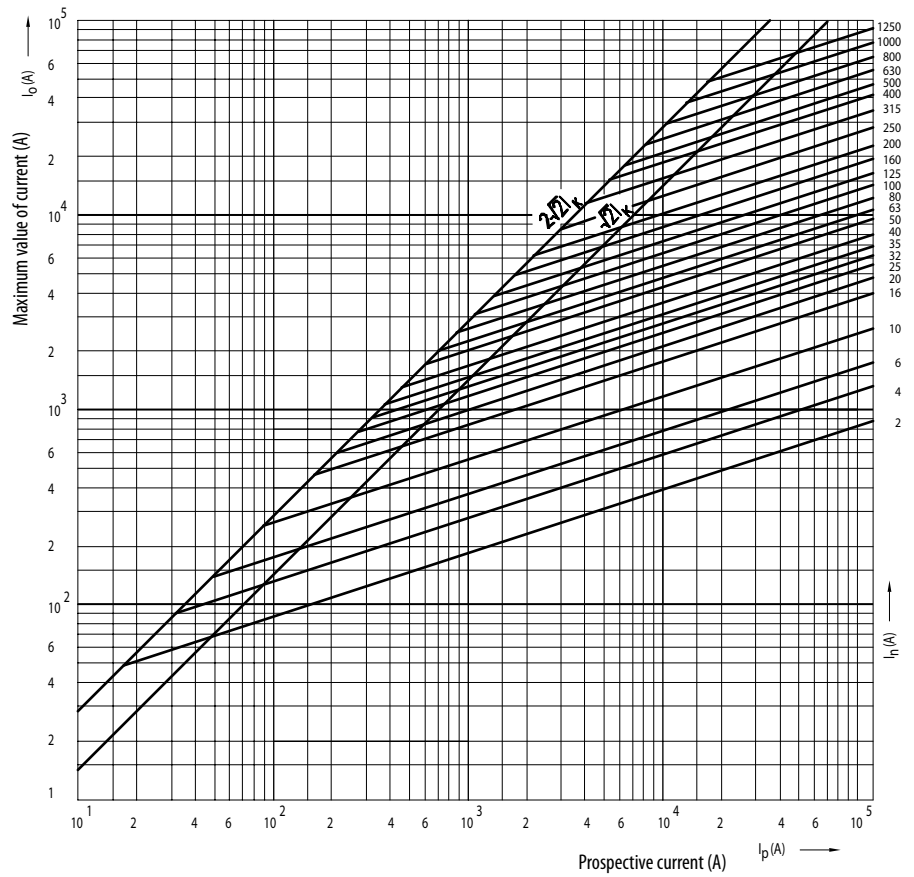

NV fuse-link aM

Time current characteristics
I/t, aM

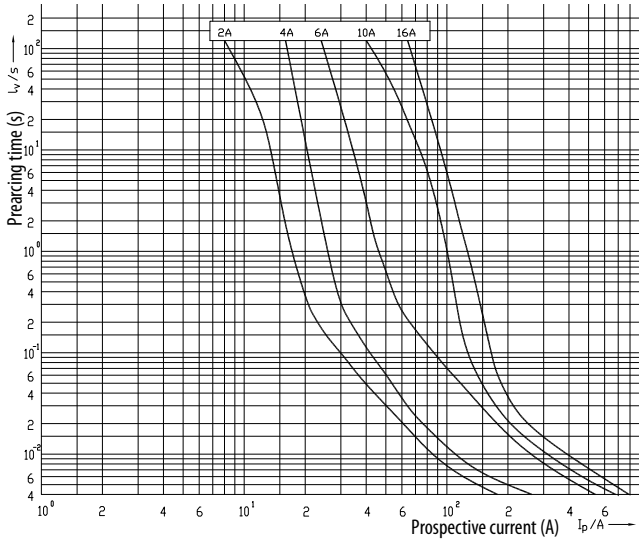

Technical data:

Rated voltage U_n	690 V AC
Rated current I_n	2-1250 A
Dimensions	DIN 43620, IEC 60269, EN 60269
Fusing characteristics	aM -> VDE 0636-2011, DIN VDE 0636
Breaking capacity at $1,1 U_n$	100 kA

Power dissipation of fuse-links NV aM 690 V a.c.

size	the highest rated current at according to VDE 0636-2011 690 V AC (A)	the maximal power dissipation 690 V AC (W)	real power dissipation of fuse-links 690 V AC (W)
NV 00	160	12	9
NV 1	250	32	28
NV 2	400	45	41
NV 3	630	60	58
NV 4a	1250	105	110

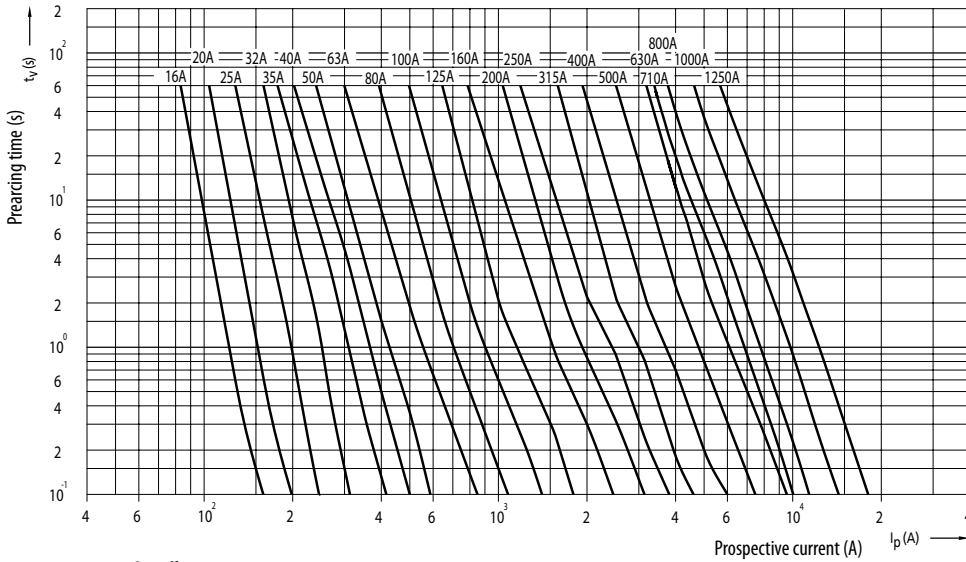

Cut-off current characteristics

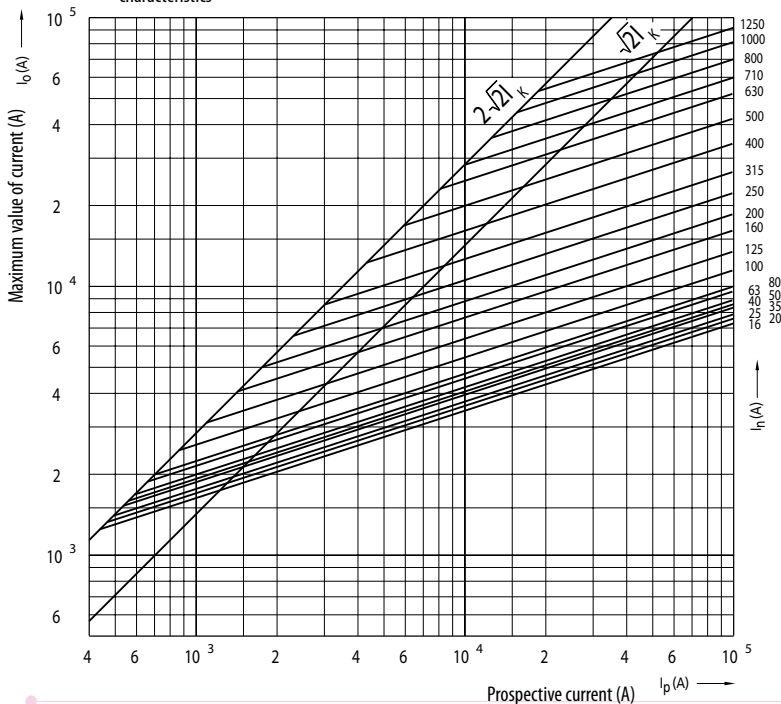

NV/NH

Technical data

Fuse-link NV/NH gF

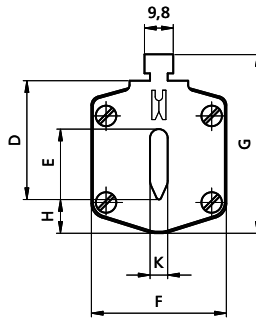
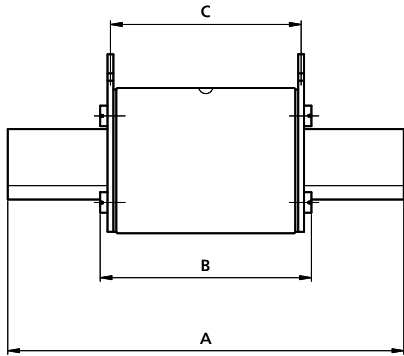

Technical data:	
Rated voltage U_n	400 V AC
Rated current I_n	20 - 250 A
Dimensions	DIN 43620, IEC 60269, EN 60269
Fusing characteristics	gF -> PN 91/E-06160/10 PN 91/E-06160/21
Breaking capacity I_n	100kA

type	dimensions											
	A	B	C	D	E	F	G	H	I	J	K	
NV00C	79	53	47	35	15	21	52	7,5				6
NV00	79	53	47	35	15	28	56	12				6
NV1C	135	68	65	40	15	28	61	12				6
NV1	135	72	65	40	20	46	65	14				6

Power dissipation of fuse-links gF 400 V a.c.

size	the highest rated current at according to PN-IEC 60269-2 (A)	the maximal power dissipation (W)	real power dissipation of fuse-links (W)
NV 00C	100	12	7,2
NV 00	160	16	15,1
NV 1C	160	23	21,9
NV 1	250	32	31,3

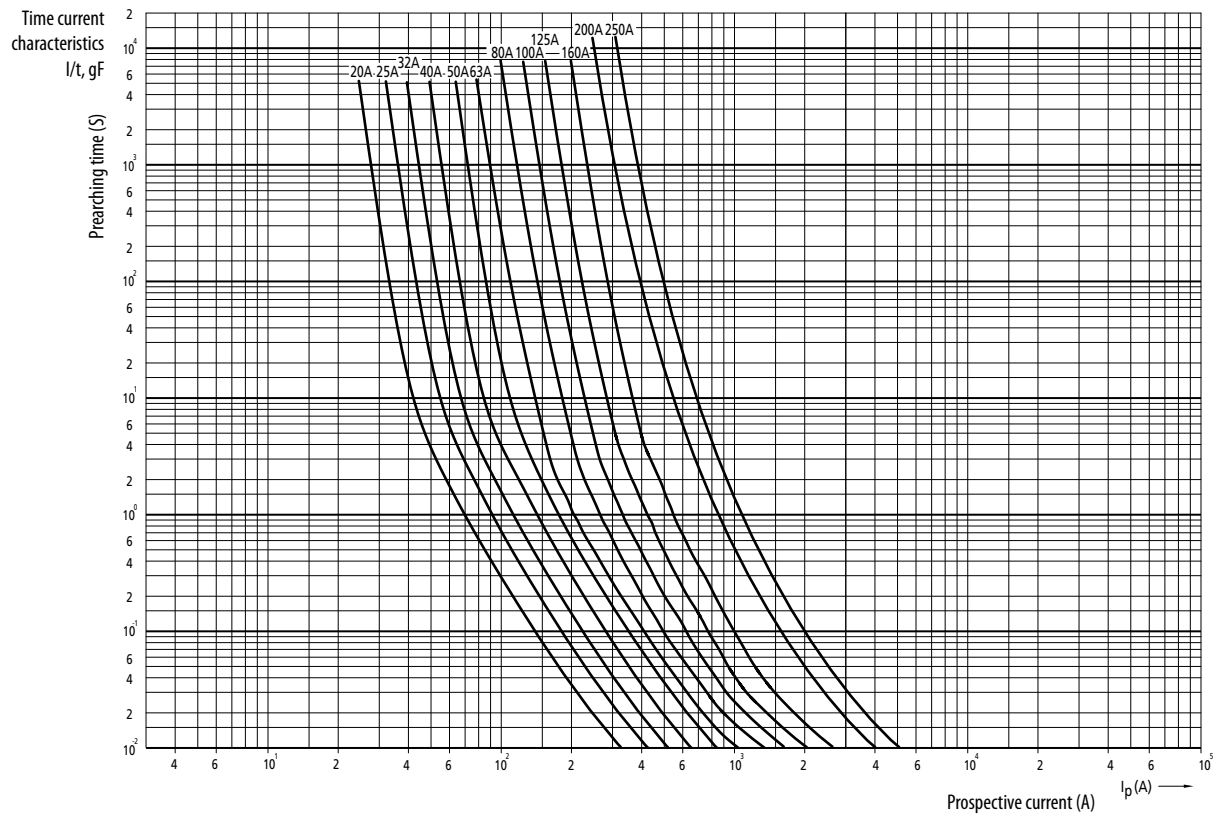

Fuse-link NV/NH gTr

Technical data:

Rated voltage	400 V AC
Rated transformer power	50-1000 kVA
Breaking capacity	100 kA

Time current characteristics
I/t, gTr

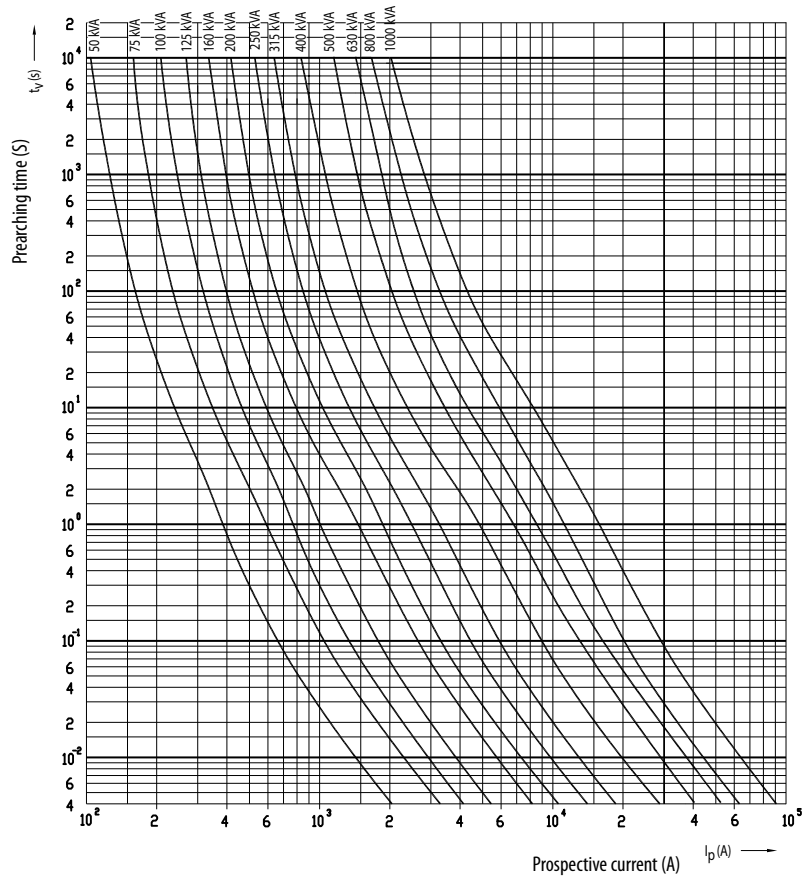

PK Fuse Bases with Ceramic Insulation sizes 00 to 3

Technical data				00	1	2	3
Size							
Electrical characteristics							
Rated voltage	U_n	V a.c.		690			
Rated current	I_n	A	160	250	400	630	
Conv. free air thermal current with fuse links	I_{th}	A	160	250	400	630	
Conv. free air thermal current with solid links	I_{th}	A	200	320	500	800	
Rated frequency		Hz	40-60				
Max. permis. power dissipation per fuse link	P_a	W	12	32	45	60	
Max. breaking capacity per fuse link	I_{cu}	kA	200				
Derating temperature factors for max. current	≤ 35	$^{\circ}C$	1				
	40	$^{\circ}C$	0,95				
	50	$^{\circ}C$	0,85				
Mechanical characteristics							
Ambient temperature range	T_{amb}	$^{\circ}C$	-25...+55				
Rated operating mode			uninterrupted				
Mounting position			vertical, horizontal				
Pollution degree			3				
Overvoltage category			III				
Degree of protection			IP00 without covers; IP20 with covers fitted				
Standards			IEC 60269-2, DIN VDE 0636, DIN 43620				

Technical data

Dimensions for size 00

1p	3p	E	F	L	P	R	S*	T*
PK 00 M8-M8 1p S	PK 00 M8-M8 3p S	M8-M8	Ø 7,5	\	\	\	88	126
PK 00 2M6-2M6 1p S	PK 00 2M6-2M6 3p S	2M6-2M6	Ø 7,5	\	\	\	88	126
PK 00 M8-2M6 1p S	PK 00 M8-2M6 3p S	M8-2M6	Ø 7,5	\	\	\	88	126
PK 00 M8-P00 1p S	PK 00 M8-P00 3p S	M8-P00	Ø 7,5	\	\	\	88	126
PK 00 M8-2P00 1p S	PK 00 M8-2P00 3p S	M8-2P00	Ø 7,5	\	\	\	88	126
PK 00 P00-P00 1p S	PK 00 P00-P00 3p S	P00-P00	Ø 7,5	\	\	\	88	126
PK 00 P00-2P00 1p S	PK 00 P00-2P00 3p S	P00-2P00	Ø 7,5	\	\	\	88	126
PK 00 2P00-2P00 1p S	PK 00 2P00-2P00 3p S	2P00-2P00	Ø 7,5	\	\	\	88	126
PKI 00 M8-M8 1p S	PKI 00 M8-M8 3p S	M8-M8	Ø 7,5	87	140	\	\	\
PKI 00 2M6-2M6 1p S	PKI 00 2M6-2M6 3p S	2M6-2M6	Ø 7,5	87	140	\	\	\
PKI 00 M8-2M6 1p S	PKI 00 M8-2M6 3p S	M8-2M6	Ø 7,5	87	140	\	\	\
PKI 00 M8-P00 1p S	PKI 00 M8-P00 3p S	M8-P00	Ø 7,5	87	140	\	\	\
PKI 00 M8-2P00 1p S	PKI 00 M8-2P00 3p S	M8-2P00	Ø 7,5	87	140	\	\	\
PKI 00 P00-P00 1p S	PKI 00 P00-P00 3p S	P00-P00	Ø 7,5	87	140	\	\	\
PKI 00 P00-2P00 1p S	PKI 00 P00-2P00 3p S	P00-2P00	Ø 7,5	87	140	\	\	\
PKI 00 2P00-2P00 1p S	PKI 00 2P00-2P00 3p S	2P00-2P00	Ø 7,5	87	140	\	\	\
PKIP 00 M8-M8 1p S	PKIP 00 M8-M8 3p S	M8-M8	Ø 7,5	87	140	95	\	\
PKIP 00 2M6-2M6 1p S	PKIP 00 2M6-2M6 3p S	2M6-2M6	Ø 7,5	87	140	95	\	\
PKIP 00 M8-2M6 1p S	PKIP 00 M8-2M6 3p S	M8-2M6	Ø 7,5	87	140	95	\	\
PKIP 00 M8-P00 1p S	PKIP 00 M8-P00 3p S	M8-P00	Ø 7,5	87	140	95	\	\
PKIP 00 M8-2P00 1p S	PKIP 00 M8-2P00 3p S	M8-2P00	Ø 7,5	87	140	95	\	\
PKIP 00 P00-P00 1p S	PKIP 00 P00-P00 3p S	P00-P00	Ø 7,5	87	140	95	\	\
PKIP 00 P00-2P00 1p S	PKIP 00 P00-2P00 3p S	P00-2P00	Ø 7,5	87	140	95	\	\
PKIP 00 2P00-2P00 1p S	PKIP 00 2P00-2P00 3p S	2P00-2P00	Ø 7,5	87	140	95	\	\

*Protective barriers; included with PK 00 3p fuse bases or sold separately

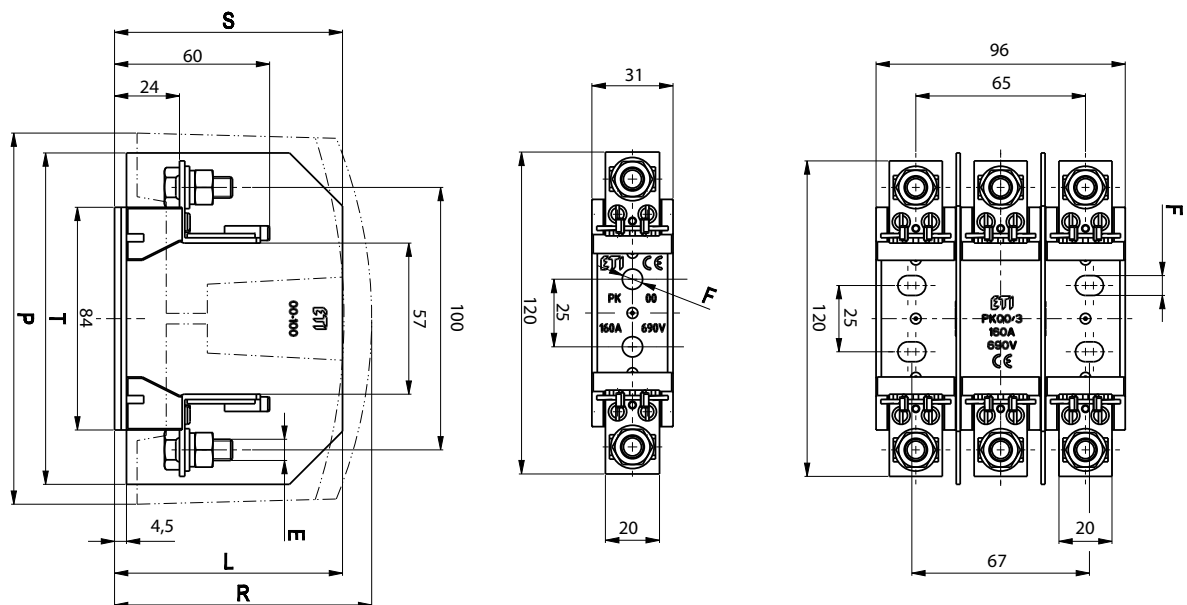

Dimensions for sizes 1, 2, 3

1p	3p	A	C	D	E	H - 1p	H - 3p	K	L**	P**	R**	S*	T*	U
PK 1 M10-M10 1p S	PK 1 M10-M10 3p S	175	141	82	M10-M10	55,5	160	200	108	245	113	108	245	106
PK 1 M10-S12 1p S	PK 1 M10-S12 3p S	175	141	82	M10-S12	55,5	160	200	108	245	113	108	245	106
PK 1 S12-S12 1p S	PK 1 S12-S12 3p S	175	141	82	S12-S12	55,5	160	200	108	245	113	108	245	106
PK 1 M10-P1 1p S	PK 1 M10-P1 3p S	175	141	82	M10-P1	55,5	160	200	108	245	113	108	245	106
PK 1 M10-2P1 1p S	PK 1 M10-2P1 3p S	175	141	82	M10-2P1	55,5	160	200	108	245	113	108	245	106
PK 1 P1-P1 1p S	PK 1 P1-P1 3p S	175	141	82	P1-P1	55,5	160	200	108	245	113	108	245	106
PK 1 P1-2P1 1p S	PK 1 P1-2P1 3p S	175	141	82	P1-2P1	55,5	160	200	108	245	113	108	245	106
PK 1 2P1-2P1 1p S	PK 1 2P1-2P1 3p S	175	141	82	2P1-2P1	55,5	160	200	108	245	113	108	245	106
PK 2 M10-M10 1p S	PK 2 M10-M10 3p S	200	166	87	M10-M10	65	185	225	115	266	125	117	266	125
PK 2 M10-S12 1p S	PK 2 M10-S12 3p S	200	166	87	M10-S12	65	185	225	115	266	125	117	266	125
PK 2 S12-S12 1p S	PK 2 S12-S12 3p S	200	166	87	S12-S12	65	185	225	115	266	125	117	266	125
PK 2 M10-P2 1p S	PK 2 M10-P2 3p S	200	166	87	M10-P2	65	185	225	115	266	125	117	266	125
PK 2 M10-2P2 1p S	PK 2 M10-2P2 3p S	200	166	87	M10-2P2	65	185	225	115	266	125	117	266	125
PK 2 P2-P2 1p S	PK 2 P2-P2 3p S	200	166	87	P2-P2	65	185	225	115	266	125	117	266	125
PK 2 P2-2P2 1p S	PK 2 P2-2P2 3p S	200	166	87	P2-2P2	65	185	225	115	266	125	117	266	125
PK 2 2P2-2P2 1p S	PK 2 2P2-2P2 3p S	200	166	87	2P2-2P2	65	185	225	115	266	125	117	266	125
PK 3 M12-M12 1p S	PK 3 M12-M12 3p S	210	166	99	M12-M12	65	208	240	127	266	135	130	266	148
PK 3 M12-P3 1p S	PK 3 M12-P3 3p S	210	166	99	M12-P3	65	208	240	127	266	135	130	266	148
PK 3 M12-2P3 1p S	PK 3 M12-2P3 3p S	210	166	99	M12-2P3	65	208	240	127	266	135	130	266	148
PK 3 P3-P3 1p S	PK 3 P3-P3 3p S	210	166	99	P3-P3	65	208	240	127	266	135	130	266	148
PK 3 P3-2P3 1p S	PK 3 P3-2P3 3p S	210	166	99	P3-2P3	65	208	240	127	266	135	130	266	148
PK 3 2P3-2P3 1p S	PK 3 2P3-2P3 3p S	210	166	99	2P3-2P3	65	208	240	127	266	135	130	266	148

*Protective barriers; included with 3p fuse bases or sold separately

**Terminal covers and fuse covers; sold separately

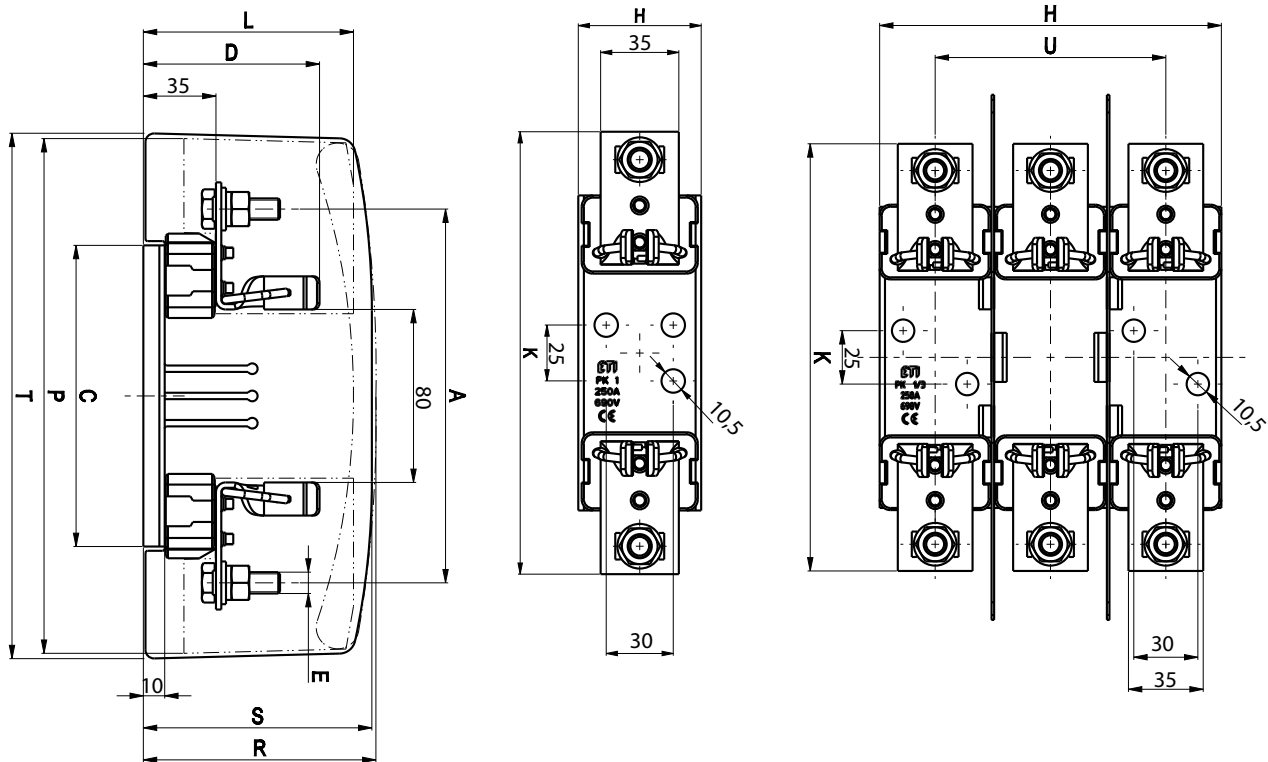

Technical data

Type of connections

	a	b	c	d	e _{max}	Tightening torque [Nm]	Connections [mm ²]
P00	24	15	15	M5	25	2,6	10-70 Cu/Al
2P00	24	15	15	M5	35	2,6	2x(10-50) Cu/Al
P1	37	20	25	M6	30	4,5	70-150 Cu/Al
2P1	37	20	25	M6	42	4,5	2x(70-95) Cu/Al
P2	42	22	28	M8	40	11	120-240 Cu/Al
2P2	42	22	28	M8	55	11	2x(120-150) Cu/Al
P3	50	25	30	M8	44	11	120-300 Cu/Al
2P3	50	25	30	M8	66	11	2x(120-240) Cu/Al
2xM6	26	15	14	M6	16	4	6-70 Cu
S12	36	16	25	M6	25	9,5	25-150Cu
M8				M8	20	10	
M10				M10	30	32	
M12				M12	30	32	
V shaped clamp	35	23	58		45	22	SM: 50-240 Cu/Al SE: 300 Cu/Al RM: 37-70 Cu/Al RE: 25-50 Cu/Al

P00, P1, P2, P3

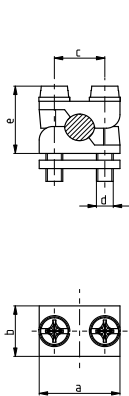

2P00, 2P1, 2P2, 2P3

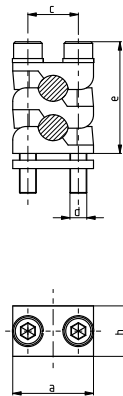

2xM6, S12

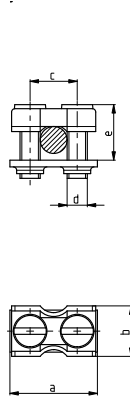

M8, M10, M12

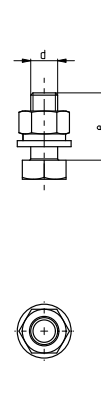

V shaped clamp

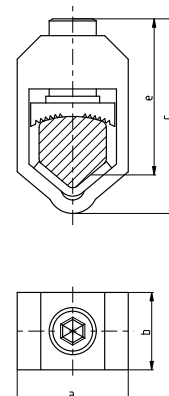

Technical data for Neutral Terminal Base / Earth Clamp

Size	00	1	2	3
Electrical characteristics				
Rated voltage	U _n	V a.c.	690	
Rated current	I _n	A	160	250 400 630
Cable terminal				
Connection		M8-2M5	M10-M10	M12-M12
Tightening torque		Nm	10-2,6	32

Dimensions for Neutral Terminal Base / Earth Clamp										
[mm]	A	B	C	D	E	F	G	H	I	J
PK 00/0 M8-2M5 S	100	84	4,5	26,5	Ø 7,5	25	\	31	20	115
PK 1 M10-M10 S	175	141	10	38	Ø 10,5	25	30	55,5	26	200
PK 2 M10-M10 S	200	166	10	40	Ø 10,5	25	30	65	30	225
PK 3 M12-M12 S	210	166	10	40	Ø 10,5	25	30	65	30	240

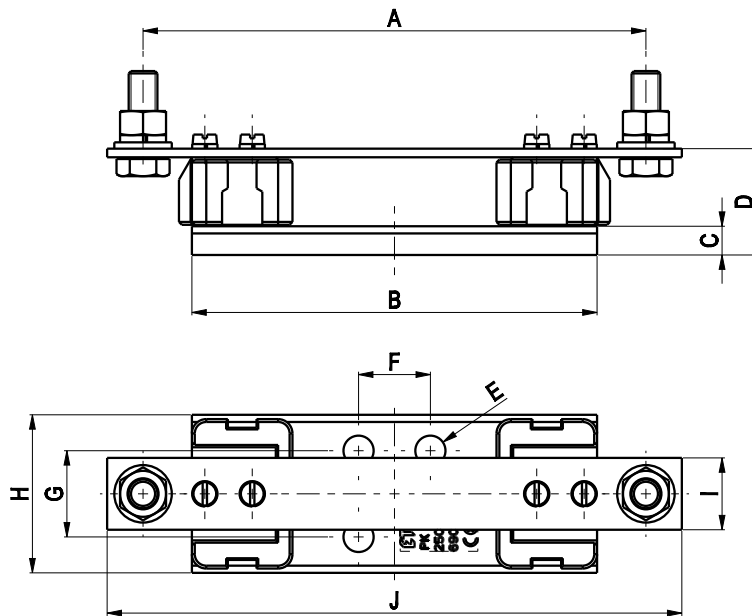

Plastic fuse bases type PT size 00 to 3

Technical data						
Size			00	1	2	3
Electrical characteristics						
Rated voltage	U_n	V a.c.	690			
Rated current	I_n	A	160	250	400	630
Conv. free air thermal current with fuse links	I_{th}	A	160	250	400	630
Conv. free air thermal current with solid links	I_{th}	A	200	320	500	800
Rated frequency		Hz	40-60			
Max. permis. power dissipation per fuse link	P_n	W	12	32	45	60
Max. breaking capacity per fuse link	I_{cu}	kA	120			
Derating temperature factors for max. current	≤ 35	°C	1			
	40	°C	0,95			
	50	°C	0,85			
Mechanical characteristics						
Ambient temperature range	T_{amb}	°C	-25...+55			
Rated operating mode			uninterrupted			
Mounting position			vertical, horizontal			
Pollution degree			3			
Overvoltage category			III			
Degree of protection			IP00 without covers; IP20 with covers fitted			
Standards			IEC 60269-2, DIN VDE 0636, DIN 43620			

Technical data

Dimensions for size 00

1p	3p	E	F	L	P	R	S*	T*
PT 00 M8-M8 1p	PT 00 M8-M8 3p	M8-M8	Ø7,5	\	\	\	86	140
PT 00 2M6-2M6 1p	PT 00 2M6-2M6 3p	2M6-2M6	Ø7,5	\	\	\	86	140
PT 00 M8-2M6 1p	PT 00 M8-2M6 3p	M8-2M6	Ø7,5	\	\	\	86	140
PT 00 M8-P00 1p	PT 00 M8-P00 3p	M8-P00	Ø7,5	\	\	\	86	140
PT 00 M8-2P00 1p	PT 00 M8-2P00 3p	M8-2P00	Ø7,5	\	\	\	86	140
PT 00 P00-P00 1p	PT 00 P00-P00 3p	P00-P00	Ø7,5	\	\	\	86	140
PT 00 P00-2P00 1p	PT 00 P00-2P00 3p	P00-2P00	Ø7,5	\	\	\	86	140
PT 00 2P00-2P00 1p	PT 00 2P00-2P00 3p	2P00-2P00	Ø7,5	\	\	\	86	140
<hr/>								
PTI 00 M8-M8 1p	PTI 00 M8-M8 3p	M8-M8	Ø7,5	87	140	\	\	\
PTI 00 2M6-2M6 1p	PTI 00 2M6-2M6 3p	2M6-2M6	Ø7,5	87	140	\	\	\
PTI 00 M8-2M6 1p	PTI 00 M8-2M6 3p	M8-2M6	Ø7,5	87	140	\	\	\
PTI 00 M8-P00 1p	PTI 00 M8-P00 3p	M8-P00	Ø7,5	87	140	\	\	\
PTI 00 M8-2P00 1p	PTI 00 M8-2P00 3p	M8-2P00	Ø7,5	87	140	\	\	\
PTI 00 P00-P00 1p	PTI 00 P00-P00 3p	P00-P00	Ø7,5	87	140	\	\	\
PTI 00 P00-2P00 1p	PTI 00 P00-2P00 3p	P00-2P00	Ø7,5	87	140	\	\	\
PTI 00 2P00-2P00 1p	PTI 00 2P00-2P00 3p	2P00-2P00	Ø7,5	87	140	\	\	\
<hr/>								
PTIP 00 M8-M8 1p	PTIP 00 M8-M8 3p	M8-M8	Ø7,5	87	140	95	\	\
PTIP 00 2M6-2M6 1p	PTIP 00 2M6-2M6 3p	2M6-2M6	Ø7,5	87	140	95	\	\
PTIP 00 M8-2M6 1p	PTIP 00 M8-2M6 3p	M8-2M6	Ø7,5	87	140	95	\	\
PTIP 00 M8-P00 1p	PTIP 00 M8-P00 3p	M8-P00	Ø7,5	87	140	95	\	\
PTIP 00 M8-2P00 1p	PTIP 00 M8-2P00 3p	M8-2P00	Ø7,5	87	140	95	\	\
PTIP 00 P00-P00 1p	PTIP 00 P00-P00 3p	P00-P00	Ø7,5	87	140	95	\	\
PTIP 00 P00-2P00 1p	PTIP 00 P00-2P00 3p	P00-2P00	Ø7,5	87	140	95	\	\
PTIP 00 2P00-2P00 1p	PTIP 00 2P00-2P00 3p	2P00-2P00	Ø7,5	87	140	95	\	\

*Protective barriers

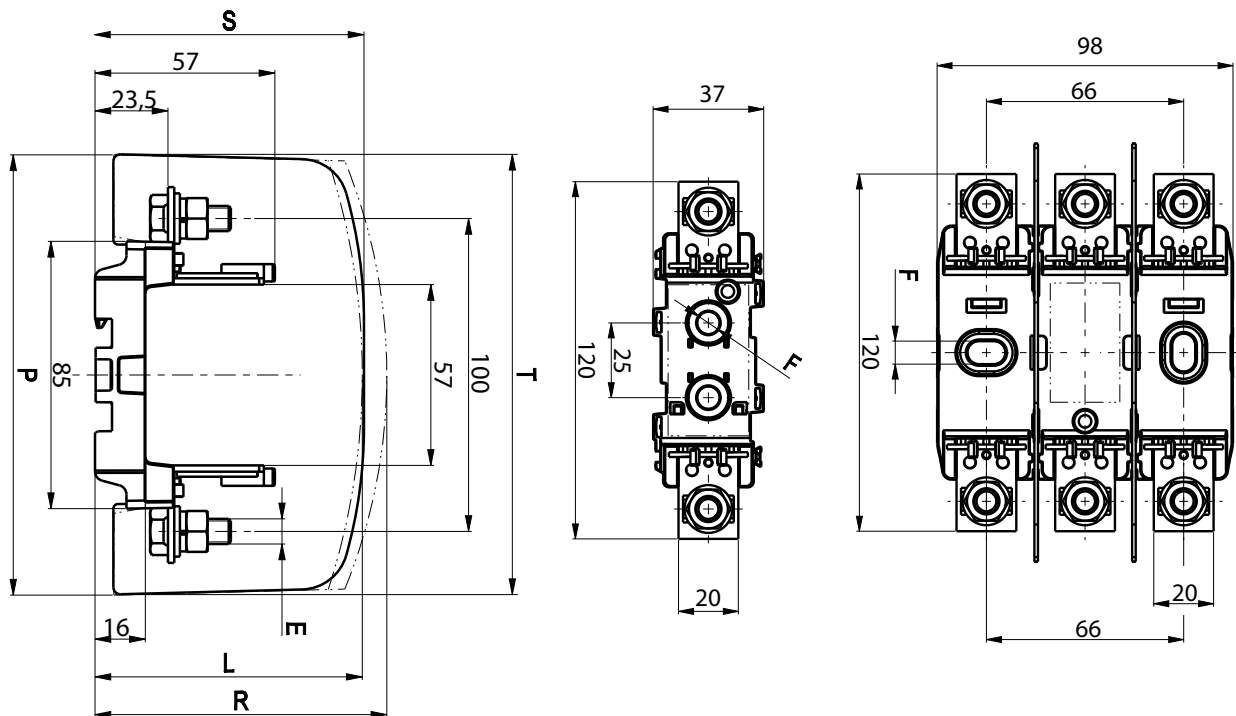

Dimensions for sizes 1, 2, 3

1p	3p	A	D	E	F	H	J	K	L**	P**	R**	S*	T*	U
PT 1 M10-M10 1p	PT 1 M10-M10 3p	175	81	M10-M10	10,5	190	25	200	103	244	110	108	241	130
PT 1 M10-S12 1p	PT 1 M10-S12 3p	175	81	M10-S12	10,5	190	25	200	103	244	110	108	241	130
PT 1 S12-S12 1p	PT 1 S12-S12 3p	175	81	S12-S12	10,5	190	25	200	103	244	110	108	241	130
PT 1 M10-P1 1p	PT 1 M10-P1 3p	175	81	M10-P1	10,5	190	25	200	103	244	110	108	241	130
PT 1 M10-2P1 1p	PT 1 M10-2P1 3p	175	81	M10-2P1	10,5	190	25	200	103	244	110	108	241	130
PT 1 P1-P1 1p	PT 1 P1-P1 3p	175	81	P1-P1	10,5	190	25	200	103	244	110	108	241	130
PT 1 P1-2P1 1p	PT 1 P1-2P1 3p	175	81	P1-2P1	10,5	190	25	200	103	244	110	108	241	130
PT 1 2P1-2P1 1p	PT 1 2P1-2P1 3p	175	81	2P1-2P1	10,5	190	25	200	103	244	110	108	241	130
PT 2 M10-M10 1p	PT 2 M10-M10 3p	200	87	M10-M10	10,5	190	25	225	112	268	120	115,5	266	130
PT 2 M10-S12 1p	PT 2 M10-S12 3p	200	87	M10-S12	10,5	190	25	225	112	268	120	115,5	266	130
PT 2 S12-S12 1p	PT 2 S12-S12 3p	200	87	S12-S12	10,5	190	25	225	112	268	120	115,5	266	130
PT 2 M10-P2 1p	PT 2 M10-P2 3p	200	87	M10-P2	10,5	190	25	225	112	268	120	115,5	266	130
PT 2 M10-2P2 1p	PT 2 M10-2P2 3p	200	87	M10-2P2	10,5	190	25	225	112	268	120	115,5	266	130
PT 2 P2-P2 1p	PT 2 P2-P2 3p	200	87	P2-P2	10,5	190	25	225	112	268	120	115,5	266	130
PT 2 P2-2P2 1p	PT 2 P2-2P2 3p	200	87	P2-2P2	10,5	190	25	225	112	268	120	115,5	266	130
PT 2 2P2-2P2 1p	PT 2 2P2-2P2 3p	200	87	2P2-2P2	10,5	190	25	225	112	268	120	115,5	266	130
PT 3 M12-M12 1p	PT 3 M12-M12 3p	210	98	M12-M12	10,5	222	10	240	126	268	133	130	267	166
PT 3 M12-P3 1p	PT 3 M12-P3 3p	210	98	M12-P3	10,5	222	10	240	126	268	133	130	267	166
PT 3 M12-2P3 1p	PT 3 M12-2P3 3p	210	98	M12-2P3	10,5	222	10	240	126	268	133	130	267	166
PT 3 P3-P3 1p	PT 3 P3-P3 3p	210	98	P3-P3	10,5	222	10	240	126	268	133	130	267	166
PT 3 P3-2P3 1p	PT 3 P3-2P3 3p	210	98	P3-2P3	10,5	222	10	240	126	268	133	130	267	166
PT 3 2P3-2P3 1p	PT 3 2P3-2P3 3p	210	98	2P3-2P3	10,5	222	10	240	126	268	133	130	267	166

*Protective barriers; included with 3p fuse bases or sold separately

**Terminal covers and fuse covers; sold separately

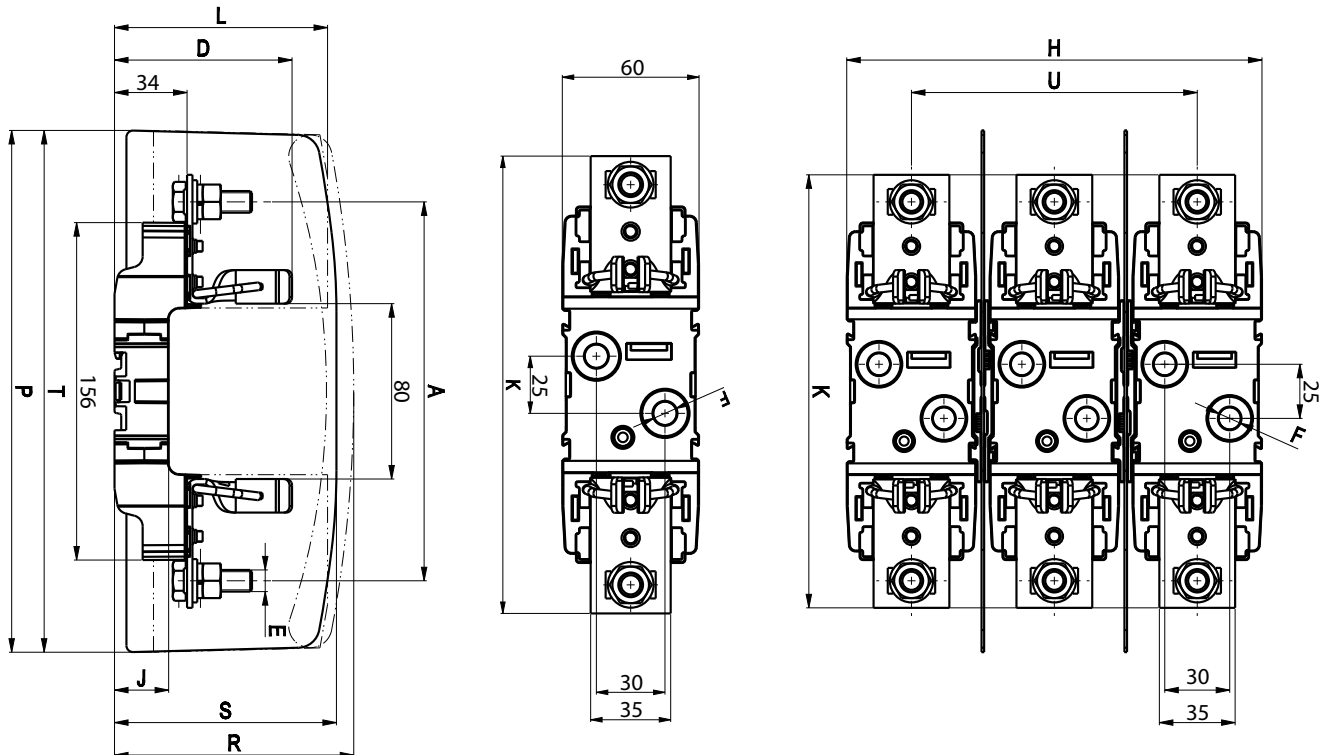

NV/NH

Technical data

Type of connections

	a	b	c	d	e _{max}	Tightening torque [Nm]	Connections [mm ²]
P00	24	15	15	M5	25	2,6	10-70 Cu/Al
2P00	24	15	15	M5	35	2,6	2x(10-50) Cu/Al
P1	37	20	25	M6	30	4,5	70-150 Cu/Al
2P1	37	20	25	M6	42	4,5	2x(70-95) Cu/Al
P2	42	22	28	M8	40	11	120-240 Cu/Al
2P2	42	22	28	M8	55	11	2x(120-150) Cu/Al
P3	50	25	30	M8	44	11	120-300 Cu/Al
2P3	50	25	30	M8	66	11	2x(120-240) Cu/Al
2xM6	26	15	14	M6	16	4	6-70 Cu
S12	36	16	25	M6	25	9,5	25-150Cu
M8				M8	20	10	
M10				M10	30	32	
M12				M12	30	32	
V shaped clamp	35	23	58		45	22	SM: 50-240 Cu/Al SE: 300 Cu/Al RM: 37-70 Cu/Al RE: 25-50 Cu/Al

P00, P1, P2, P3

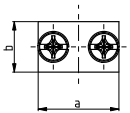
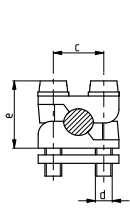

2P00, 2P1, 2P2, 2P3

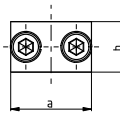
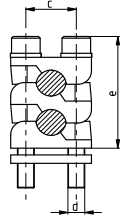

2xM6, S12

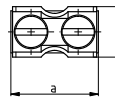
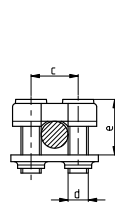

M8, M10, M12

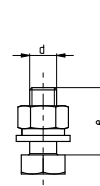

V shaped clamp

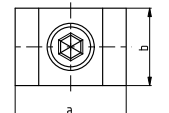
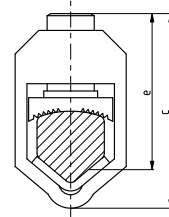

Technical data for Neutral Terminal Base / Earth Clamp

Size	00	1	2	3
Electrical characteristics				
Rated voltage	U _n	V a.c./d.c.	690	
Rated current	I _n	A	160	250 400 630
Cable terminal				
Connection		M8-2M5	M10-M10	M12-M12
Tightening torque		Nm	10-2,6	32

Dimensions for Neutral Terminal Base / Earth Clamp										
[mm]	A	B	C	D	E	F	G	H	I	J
PT 00/0 M8-2M5 S	100	85	4,5	26,5	Ø 7,5	25	\	37	20	115
PT 1 M10-M10 S	175	156	10	38	Ø 10,5	25	30	60	26	200
PT 2 M10-M10 S	200	156	10	40	Ø 10,5	25	30	60	30	225
PT 3 M12-M12 S	210	156	10	40	Ø 10,5	25	30	60	30	240

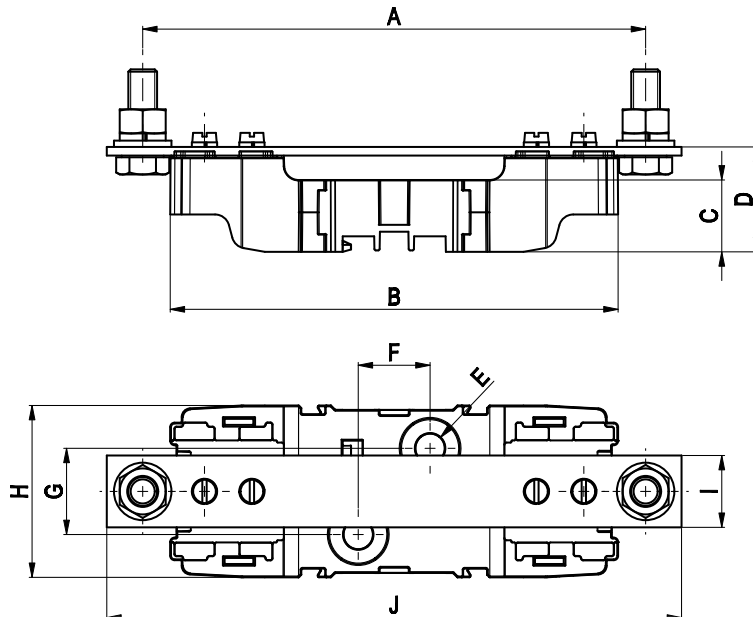

Plastic fuse bases type PLNVV 000 and 00 (fuses with screw connection - S)

Technical data:	
Rated voltage U_n	690 V AC
Rated current I_n	160 A - sizes 00C, 00, 0 250 A - size 1 400 A - size 2 630 A - size 3
Degree of pollution	3 -> IEC 60947, DIN EN 60947, DIN VDE 0110
Standards	IEC 60269, DIN EN 60269, DIN VDE 0636, HRN EN 60269

Dimensions

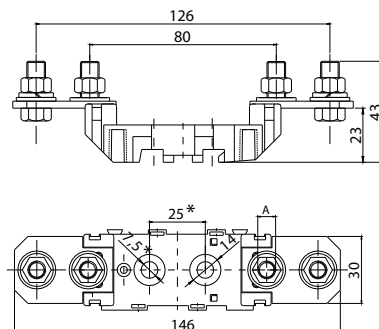

	A
PLNVV -000	M8
PLNVV -00	M10

Technical data

Neutral terminal base PLNS

PLNS - 00 N

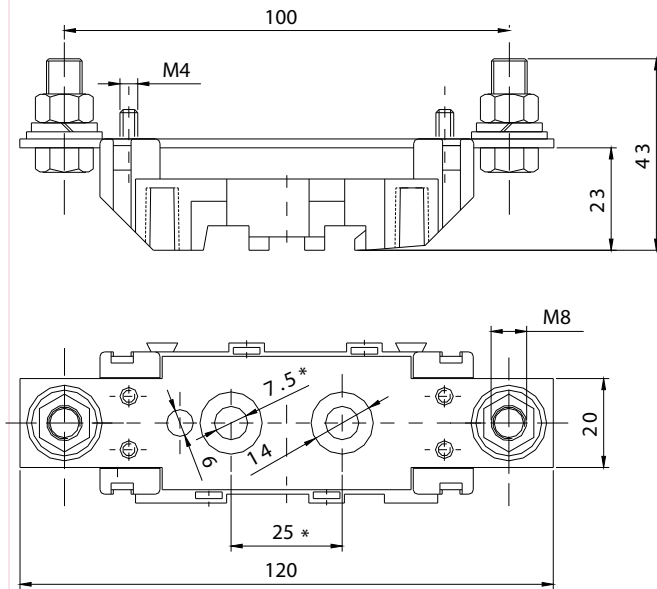

2PLNS - 1,2 N

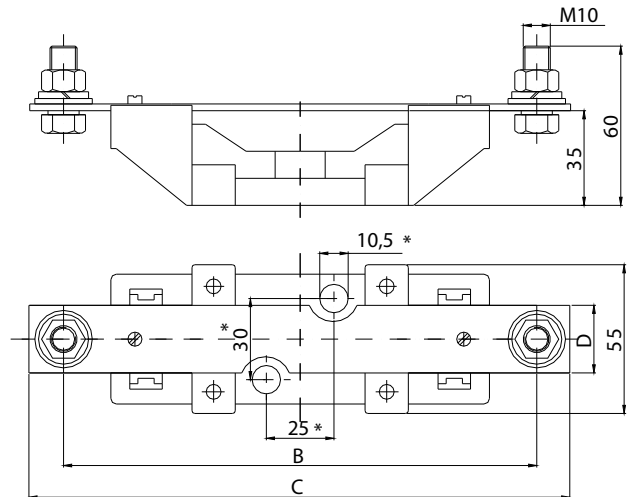

	2PLNS - 1N	2PLNS - 2N
B	175,6	200
C	200	230
D	25	30

OS 00, OS 12

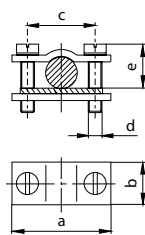

P00, P1, P2, P3

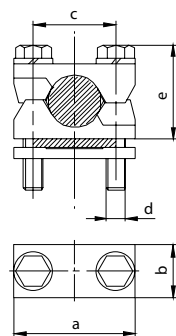

P002, P12, P22, P32

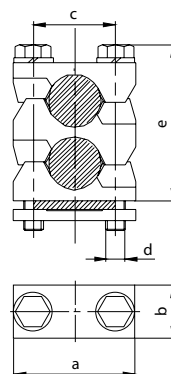

"V" shaped clamp

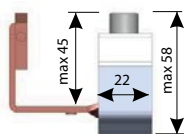

Technical data

Type	a	b	c	d	e _{max}
OS00	24	15	15	M5	15
OS12	36	16	25	M6	25
P00	24	15	15	M5	25
P002	24	15	15	M5	35
P1	37	20	25	M6	30
P12	37	20	25	M6	42
P2	42	22	28	M8	40
P22	42	22	28	M8	55
P3	50	25	30	M8	44
P32	50	25	30	M8	66

Accessories

NV separator - Drawing A

Type	dimension				
	I _N (A)	A	B	C	D
NV L 00	160	77,5	49	15	35
NV L 0	160	125	68	15	35
NV L 1	250	133	68	20	40
NV L 2	400	148	68	26	48
NV L 3	630	148	68	33	60

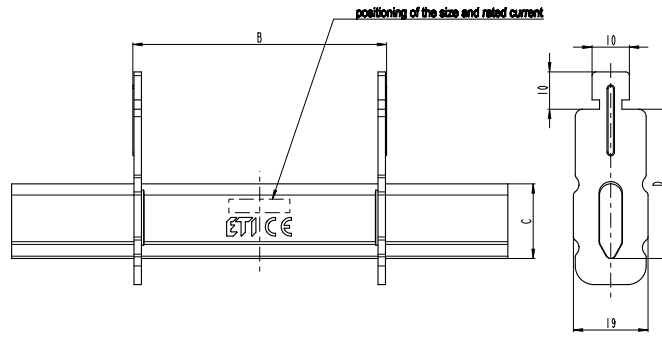

NV separator - Drawing B

type	dimension				
	A	B	C	D	E
NV L 4	68	51	87	200	150
NV L 4a	89	50	86	200	-

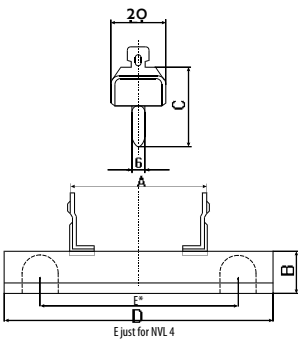
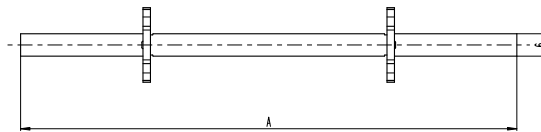

R 00-3 dimension

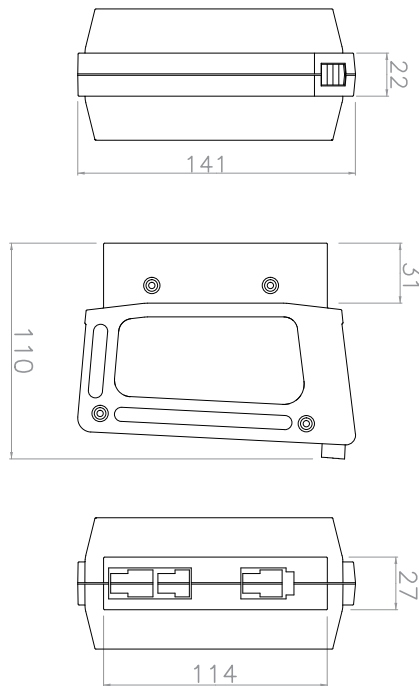

VRRN 00-3 dimension

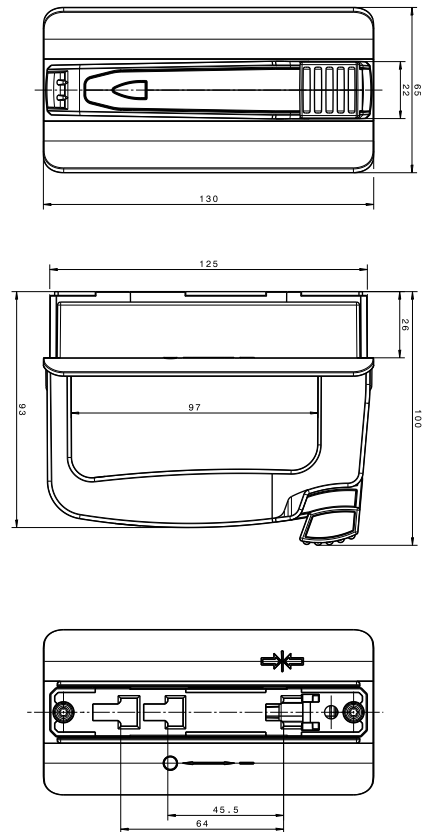

Insulating sleeve of contact spring PK and PP

type	dimension		
	A	B	C
PP 00	32	68	41
PK 1	40	52	33
PK 2	44	63	40
PK 3	44	67	40

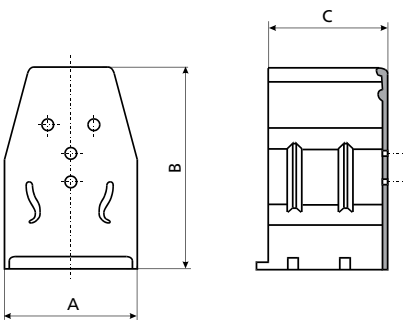

VRRL 85 dimension

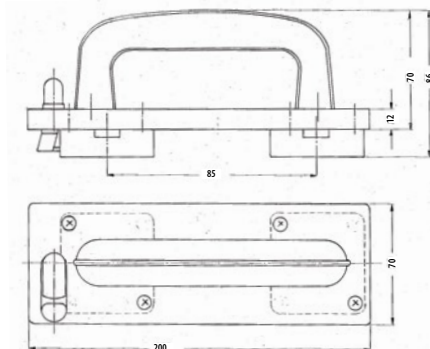

Base separating element

type	dimension	
	A	B
PP 00, PK 00	125	83
PK 0	175	82
PK 1	210	100
PK 2	240	110
PK 3	250	110

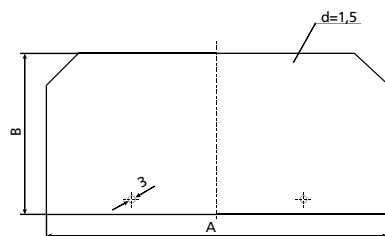

Technical data

NV fuse-rail sizes 00, 1, 2, 3

Technical data of insulated fuse-rails (in accordance with VDE 0636, part 201, IEC 60269-2-1)

Technical Specifications			VL00/100	VL00/185	VL1	VL1H
Electrical Characteristics						
Rated operational voltage	U_e	V	690 AC	690 AC	690 AC	690 AC
Rated operational current	I_e	A	160	160	250	250
Rated frequency	-	Hz	40-60	40-60	40-60	40-60
Rated insulation voltage	U_i	V	800 AC		1000 AC	
Total power loss at I_n (without fuse)	P_v	W	18	23	23	29
Fuse links						
Size - DIN 43 620, IEC 60269-2	-	-	000/00		1	
Max. rated current (gG)	I_n	A	160	160	250	250
Max. permissible power loss per fuse link	P_v	W	12		32	23
Dimensions						
Mass	-	kg	100 mm = 0,8	185mm=1,5	3,5	
Busbars (distance)	-	mm	100	185	185	
Cable connection						
Screw	-	-	M8		M10	
Torque	M_a	Nm	12-15		30-35	
V-clip	-	mm ²	10-95		25-300	25-240 / 25-300
Torque	M_a	Nm	10		32	
Protection						
Operational state	-	-	IP10			
Operating conditions						
Ambient temperature	T_u	°C	-25 ... +55			
Operating condition	-	-	Continuous operation			
Mounting	-	-	vertical, horizontal			
Altitude	-	m	≤ 2000			
Pollution degree	-	-	3			
Overvoltage category	-	-	III	IV		

Technical data of insulated fuse-rails (in accordance with VDE 0636, part 201, IEC 60269-2-1)

Technical Specifications			VL2	VL2H	VL3
Electrical Characteristics					
Rated operational voltage	U_e	V	690 AC	690 AC	690 AC
Rated operational current	I_e	A	400	400	630
Rated frequency	-	Hz	40-60	40-60	40-60
Rated insulation voltage	U_i	V		1000 AC	
Total power loss at I_n (without fuse)	P_v	W	54	73	115
Fuse links					
Size - DIN 43 620, IEC 60269-2	-	-	2		3
Max. rated current (gG)	I_n	A	400	400	630
Max. permissible power loss per fuse link	P_v	W	45	34	48
Dimensions					
Mass	-	kg	3,8		4,3
Busbars (distance)	-	mm	185		
Cable connection					
Screw	-	-	M12	M12	M12
Torque	M_a	Nm	35-40	35-40	35-40
V-clip	-	mm ²	25-300	25-240 / 25-300	25-300
Torque	M_a	Nm	32	32	32
Protection					
Operational state	-	-	IP10		
Operating conditions					
Ambient temperature	T_u	°C	-25 ... +55		
Operating condition	-	-	Continuous operation		
Mounting	-	-	vertical, horizontal		
Altitude	-	m	≤ 2000		
Pollution degree	-	-	3		
Overvoltage category	-	-	IV		

Dimensional overview of VL NV fuse-rails

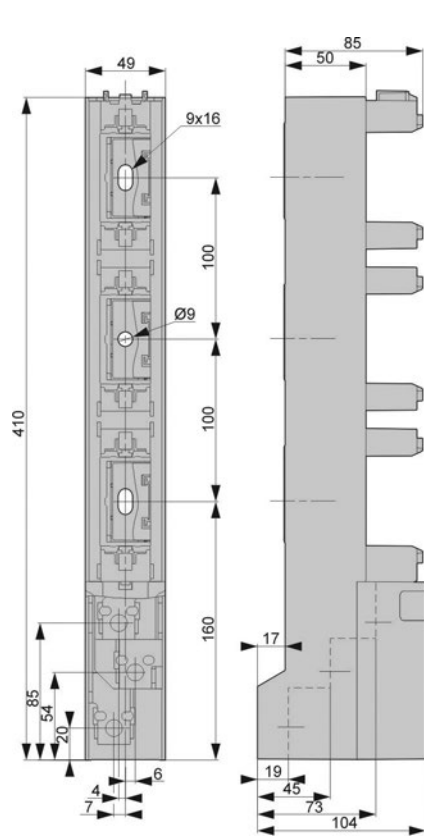

size 00/100

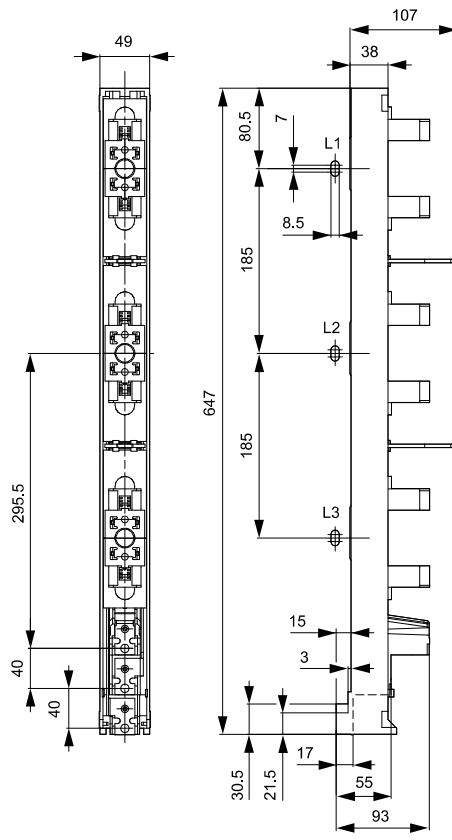

size 00/185

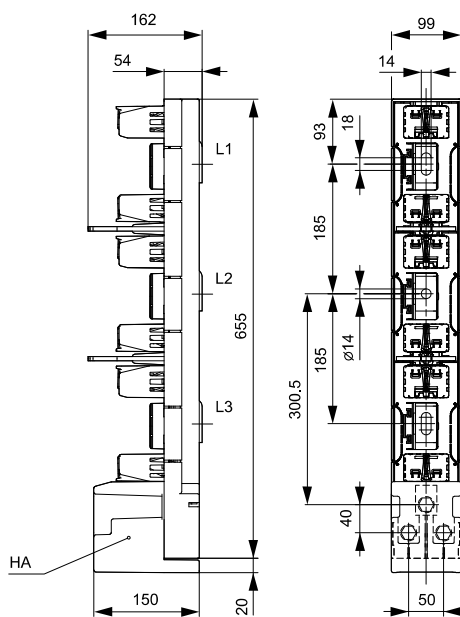
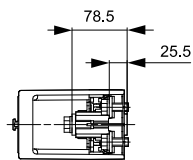
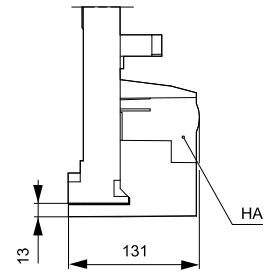

size 1, 2, 3 (M terminal)

Technical data

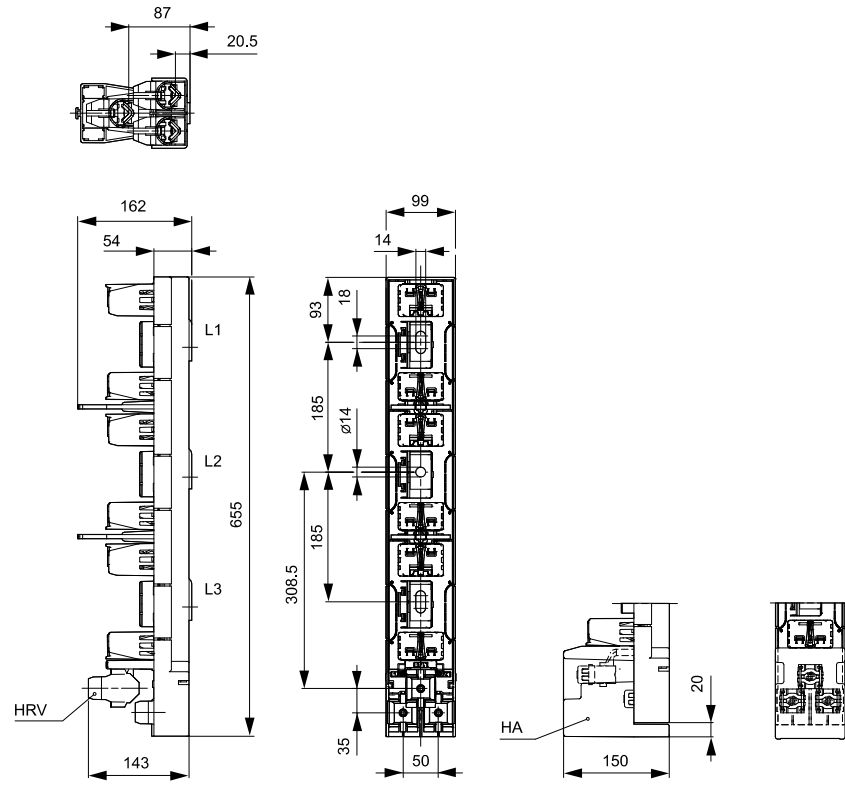

size 1, 2, 3 (SP terminal)

Dimensional overview of accessories for VL NV fuse-rails

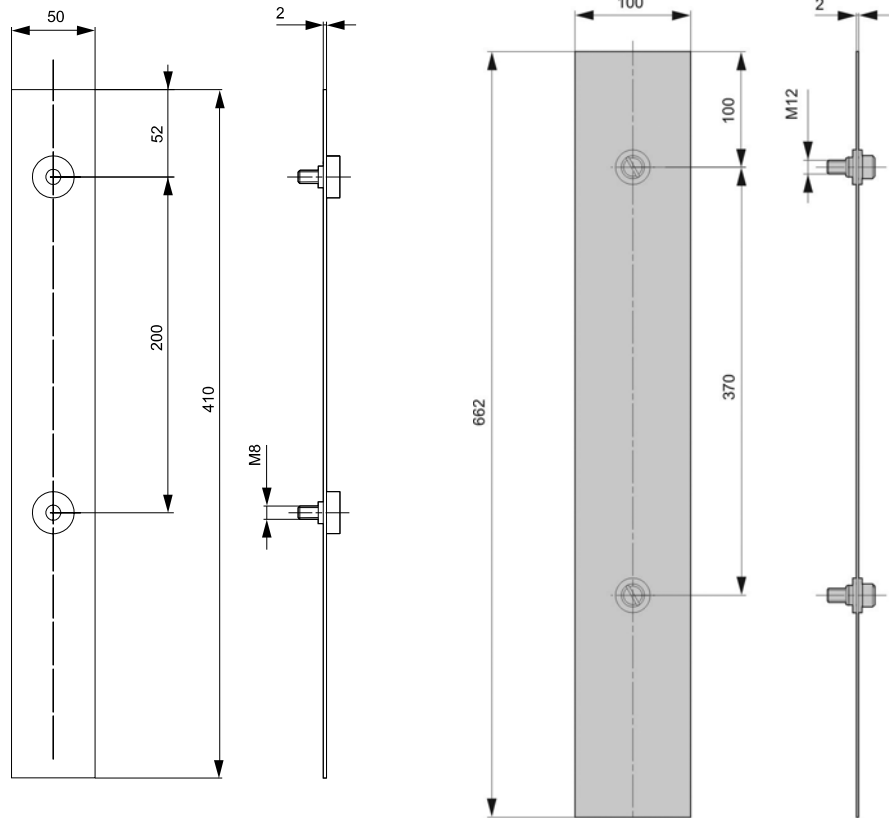

busbar covering PZ 00/100

busbar covering PZ 123/185, busbar covering PZ 00/185

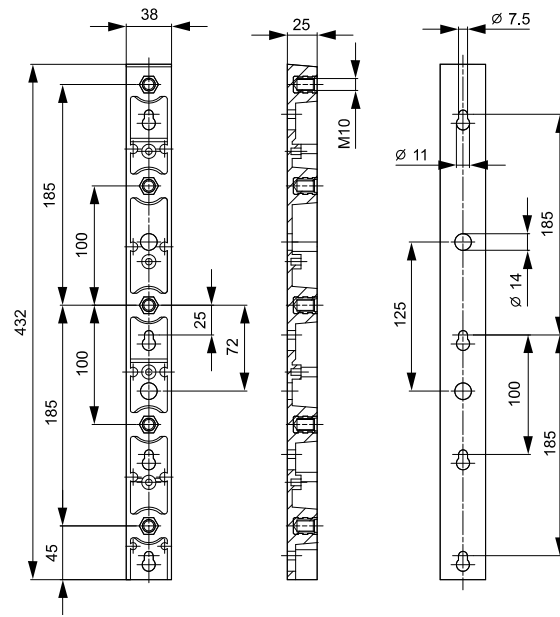
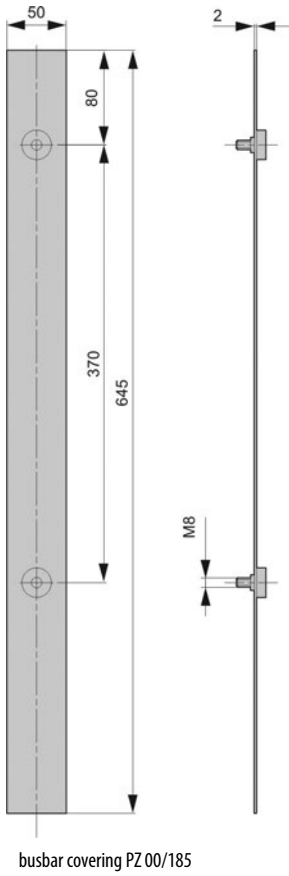

NV fuse-rail type VL00 EK

Technical data

Type	VL00/100 EK	
Conventional free air thermal current (Ith)	A	160
Rated insulation voltage	V	AC690
Rated withstand impulse voltage	Kv	6
Rated frequency	Hz	50 (40-60)
Power dissipation (without fuse-links)	W	16,6
Degree of protection (cover closed)		IP20
Degree of protection (cover opened)		IP20
Pollution degree		3
Permissible ambient temperature**	°C	-25°C ... +55°C
Storage temperature	°C	-30°C ... +70°C
Weight (without fuse-links)	kg	0,86
Package	pcs	1

** with ambient temperature between 40-45°C, reduce Ith by 5%;
with ambient temperature above 45°C, reduce Ith by 10%

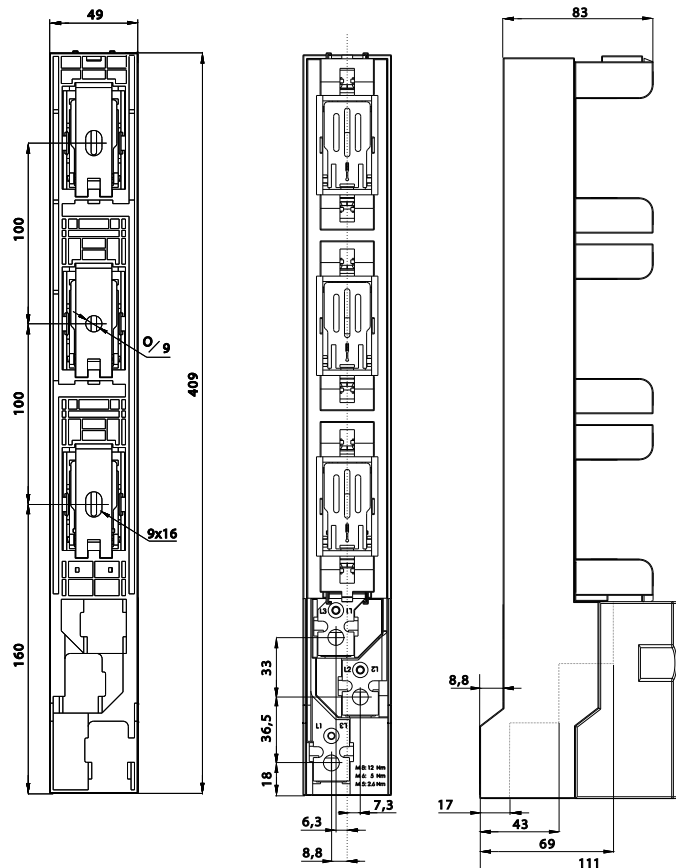

Technical data

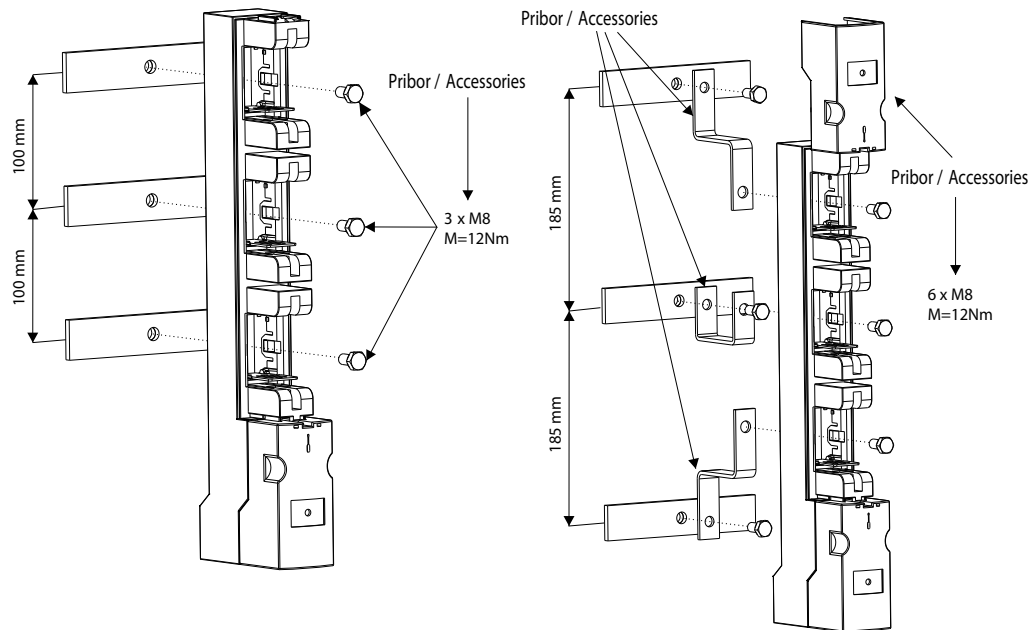

NV Strip type fuse-switch-disconnector sizes 00, 1, 2, 3

Technical data of NV strip type fuse-switch-disconnectors (in accordance with IEC/EN 60947-3)				SL00/100			SL00/185			SL1	
Technical Specifications				SL00/100			SL00/185			SL1	
Electrical Characteristics											
Rated operational voltage	U_e	V	500 AC	690 AC	400 AC	500 AC	690 AC	400 AC	500 AC	690 AC	400 AC
Rated operational current	I_e	A	160	100	160	160	160	160	250	250	250
Rated frequency	-	Hz	40-60	40-60	40-60	40-60	40-60	40-60	40-60	40-60	40-60
Rated insulation voltage	U_i	V	AC 800						AC 1000		
Total power loss at I_n (without fuse)	P_v	W	18			23					
Utilization category	-	-	AC22B	AC22B	AC22B	AC23B	AC22B	AC23B	AC22B	AC22B	AC23B
Fuse links											
Size - DIN 43 620, IEC 60269-2	-	-	000/00						1		
Max. rated current (gG)	I_n	A	160	100	160	160	160	160	250	250	250
Max. permissible power loss per fuse link	P_v	W	12						32		
Dimensions											
Mass	-	kg	100 mm = 1,40			185mm=2,4			4,9		
Busbars (distance)	-	mm	100			185			185		
Cable connection											
Screw	-	-				M8			M10		
Torque	M_a	Nm				12-15			30-35		
V-clip	-	mm ²				10-95			25-300		
Torque	M_a	Nm				15			32		
Protection											
Operational state	-	-				IP30			IP30		
Cover open	-	-				IP10			IP10		
Operating conditions											
Ambient temperature	T_u	°C				-25 ... +55			-25 ... +55		
Operating condition	-	-				Continuous operation					
Mounting	-	-				vertical, horizontal					
Altitude	-	m				≤ 2000					
Pollution degree	-	-				3					
Overvoltage category	-	-	III						IV		

Technical data of NV strip type fuse-switch-disconnectors (in accordance with IEC/EN 60947-3)

Technical Specifications			SL1H			SL2		
Electrical Characteristics								
Rated operational voltage	U_e	V	500 AC	690 AC	400 AC	500 AC	690 AC	400 AC
Rated operational current	I_e	A	250			400	400	400
Rated frequency	-	Hz	40-60			40-60	40-60	40-60
Rated insulation voltage	U_i	V	AC 1000					
Total power loss at I_n (without fuse)	P_v	W	29			54		
Utilization category	-	-	AC22B	AC21B	AC23B	AC22B	AC21B	AC23B
Fuse links								
Size - DIN 43 620, IEC 60269-2	-	-	1			2		
Max. rated current (gG)	I_n	A	250			400	400	400
Max. permissible power loss per fuse link	P_v	W	23			45		
Dimensions								
Mass	-	kg	4,9					
Busbars (distance)	-	mm	185					
Cable connection								
Screw	-	-	M10			M12		
Torque	M_a	Nm	30-35			35-40		
V-clip	-	mm ²	25-240 / 25-300			25-300		
Torque	M_a	Nm	32					
Protection								
Operational state	-	-	IP30					
Front cover open	-	-	IP10					
Operating conditions								
Ambient temperature	T_u	°C	-25 ... +55					
Operating condition	-	-	Continuous operation					
Mounting	-	-	vertical, horizontal					
Altitude	-	m	≤ 2000					
Pollution degree	-	-	3					
Overvoltage category	-	-	IV					

Technical data of NV strip type fuse-switch-disconnectors (in accordance with IEC/EN 60947-3)

Technical Specifications			SL2H			SL3		
Electrical Characteristics								
Rated operational voltage	U_e	V	500 AC	690 AC	400 AC	500 AC	690 AC	400 AC
Rated operational current	I_e	A	400			630	630	630
Rated frequency	-	Hz	40-60			40-60	40-60	40-60
Rated insulation voltage	U_i	V	AC 1000					
Total power loss at I_n (without fuse)	P_v	W	73			115		
Utilization category	-	-	AC22B	AC21B	AC23B	AC22B	AC21B	AC23B
Fuse links								
Size - DIN 43 620, IEC 60269-2	-	-	2			3		
Max. rated current (gG)	I_n	A	400			630	630	630
Max. permissible power loss per fuse link	P_v	W	34			48		
Dimensions								
Mass	-	kg	4,9			5,6		
Busbars (distance)	-	mm	185					
Cable connection								
Screw	-	-	M12			M12		
Torque	M_a	Nm	35-40			35-40		
V-clip	-	mm ²	25-240 / 25-300			25-300		
Torque	M_a	Nm	32					
Protection								
Operational state	-	-	IP30					
Front cover open	-	-	IP10					
Operating conditions								
Ambient temperature	T_u	°C	-25 ... +55					
Operating condition	-	-	Continuous operation					
Mounting	-	-	vertical, horizontal					
Altitude	-	m	≤ 2000					
Pollution degree	-	-	3					
Overvoltage category	-	-	IV					

Technical data

Dimensional overview of NV strip type fuse-switch-disconnectors

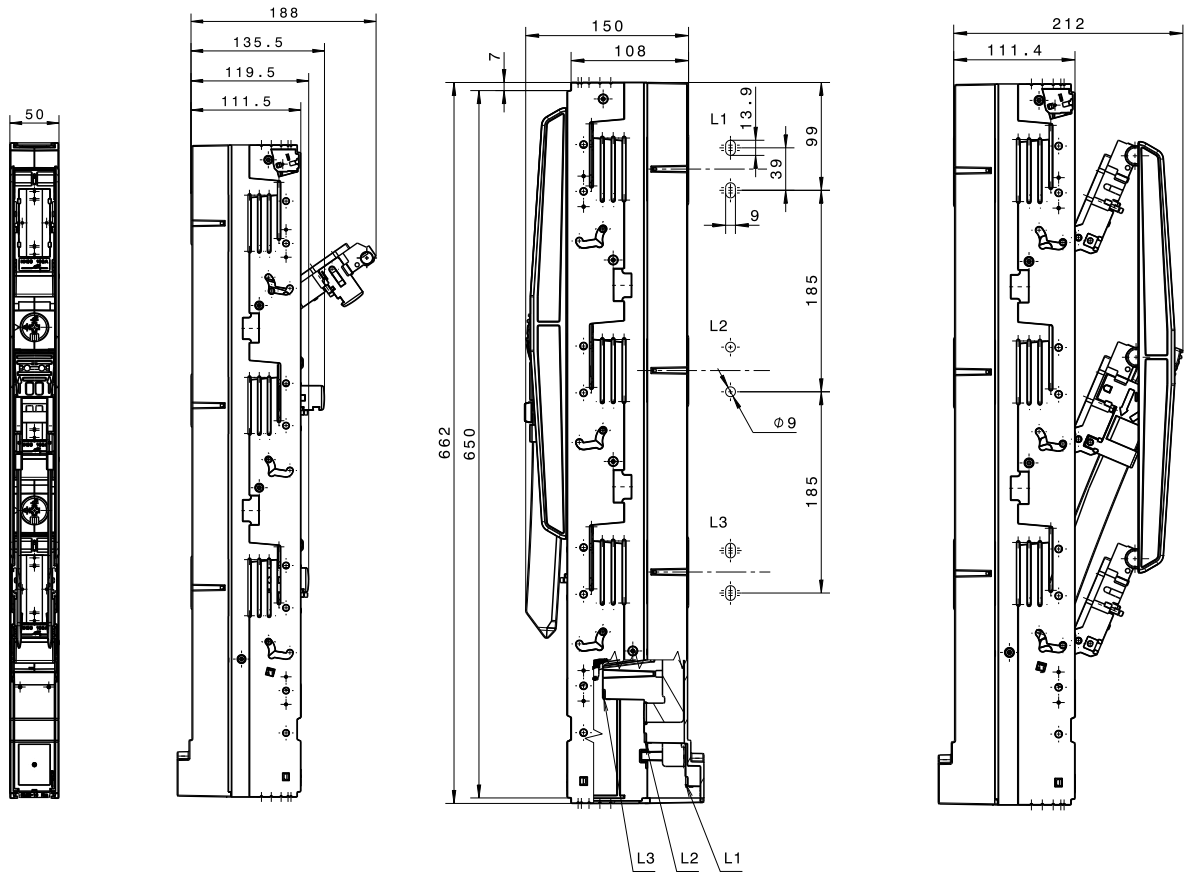
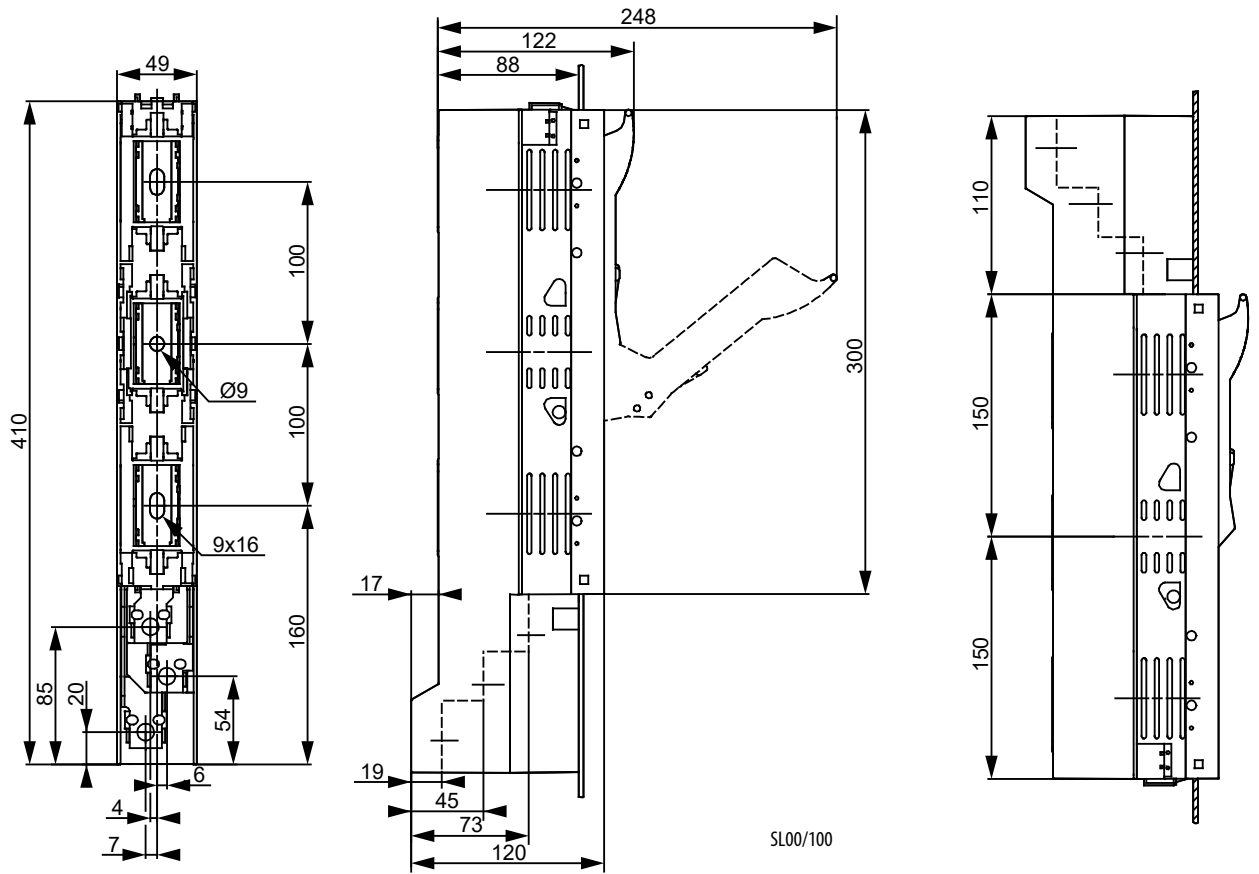

SL00/185

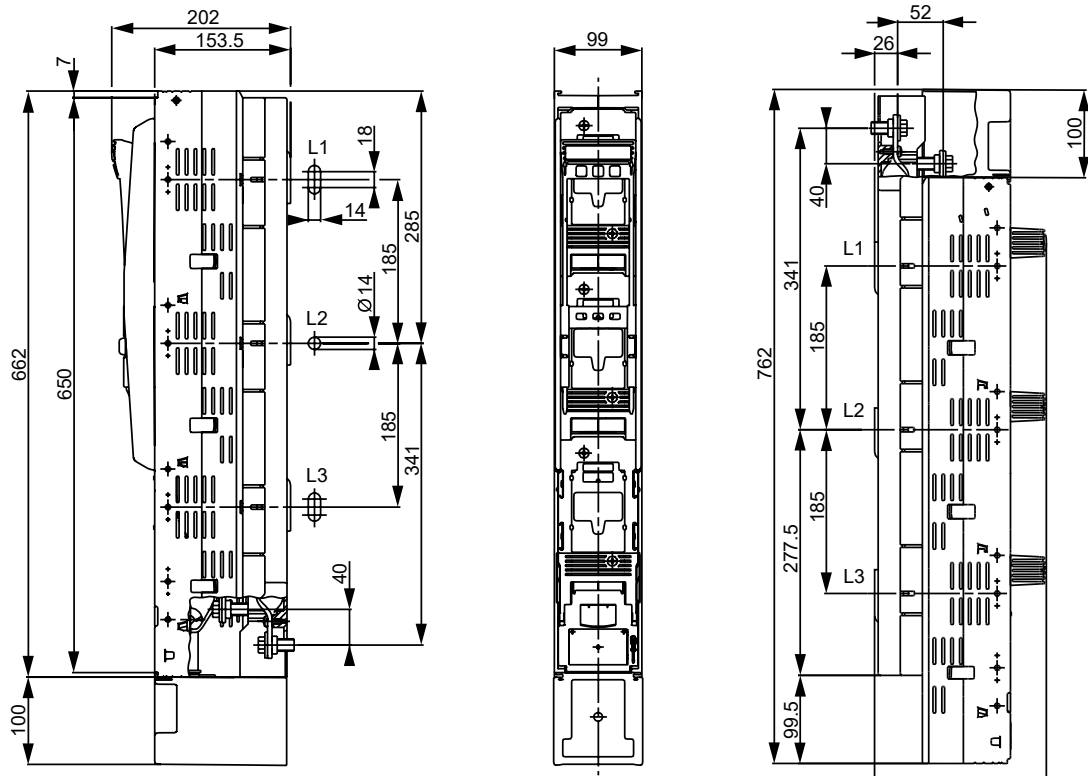

SL1(H), SL2(H), SL3

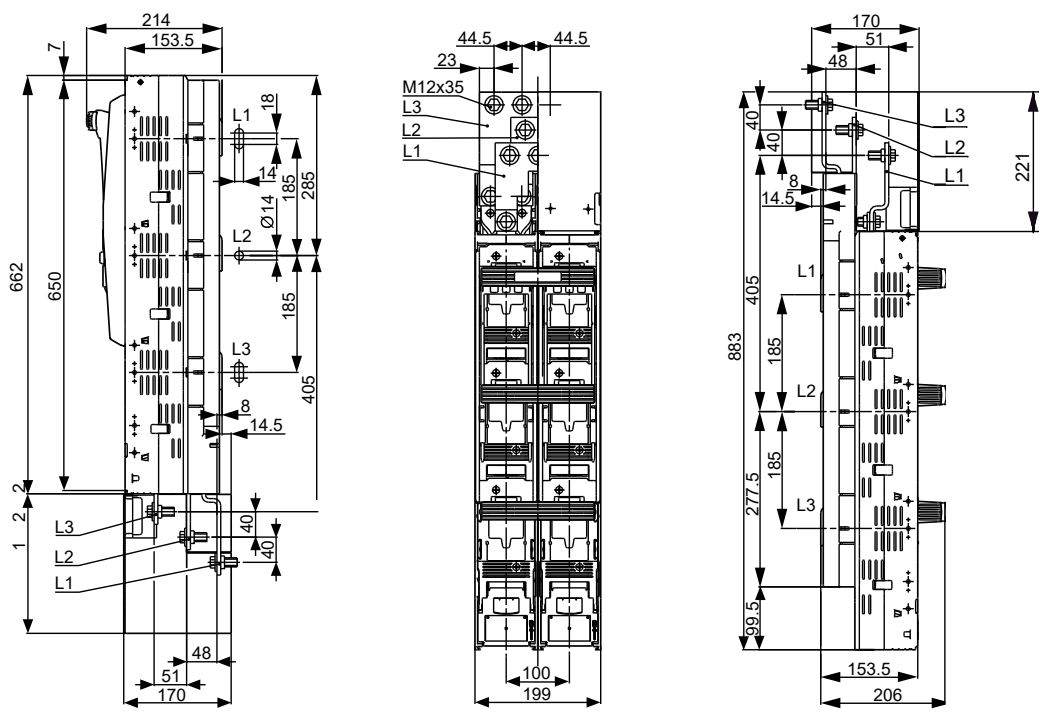

SL3 DOUBLE

NV/NH

Technical data

Dimensional overview of accessories for NV strip type fuse-switch-disconnectors

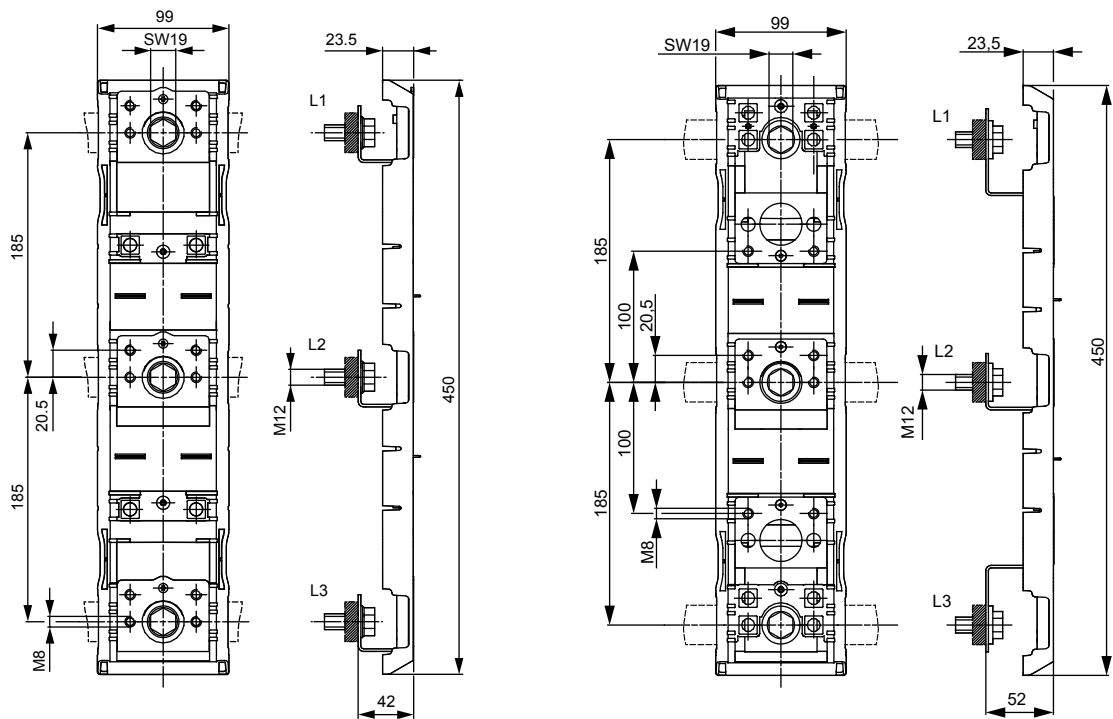

adapter DA 185-185/42

adapter DA 185-100/52

Strip type fuse-switch disconnectors type SL00 EK

Technical data		SL00/100 EK		
Type				
Conventional free air thermal current (I _{th})	A	160		
Rated insulation voltage	V	AC690		
Rated withstand impulse voltage	Kv	6		
Rated frequency	Hz	50 (40-60)		
Rated operational (making and breaking) voltage	V	400V	500V	690 V
Utilization category/Rated operational (making and breaking) current	AC21-B	160A	160A	125A
Utilization category/Rated operational (making and breaking) current	AC22-B	160A	160A	100A
Rated conditional short-circuit current	kA _{eff}	63		
Mechanical durability (operating cycles)		1400		
Electrical durability (operating cycles)		200		
Power dissipation (without fuse-links)	W	19,5		
Degree of protection (cover closed)		IP30		
Degree of protection (cover opened)		IP20		
Pollution degree		3		
Permissible ambient temperature**	°C	-25°C ... +55°C		
Storage temperature	°C	-30°C ... +70°C		
Weight (without fuse-links)	kg	1,2		
Package	pcs	1		

** with ambient temperature between 40-45°C, reduce I_{th} by 5%; with ambient temperature above 45°C, reduce I_{th} by 10%

Dimensions

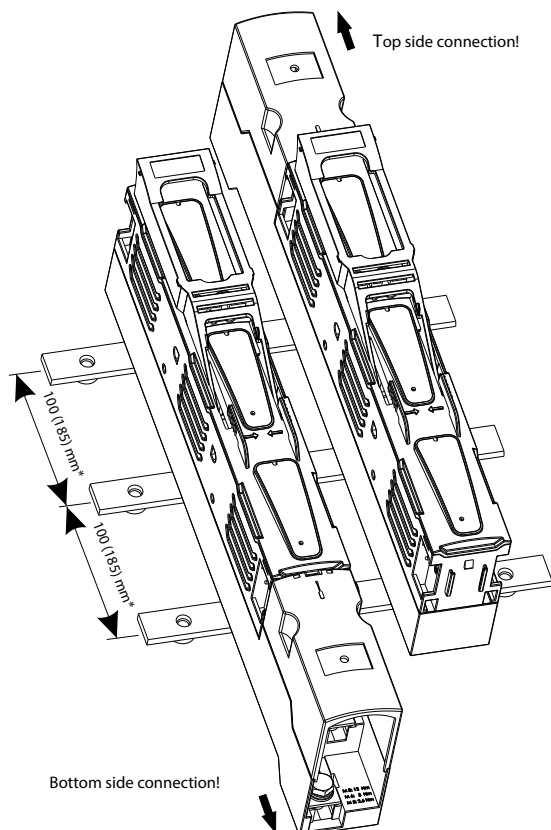
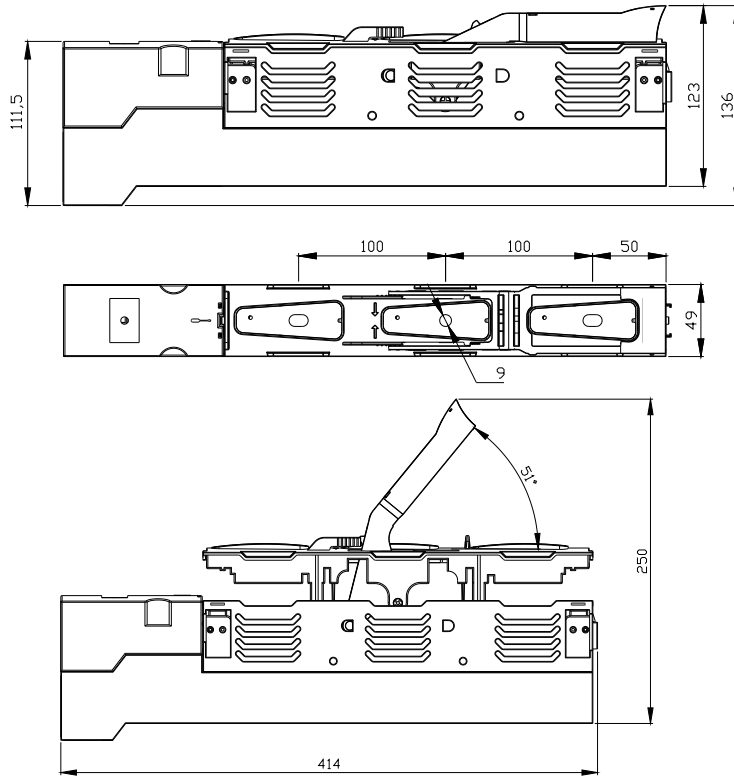

Technical data

Horizontal fuse-switch disconnecter type KVL size 00, 1, 2, 3 (baseplate mounting)

Technical data (in accordance with IEC/EN 60947-3)

Size	00						1							
Technical Characteristics														
Rated operational voltage	U _e	V	400 AC	500 AC	690 AC	250 DC	440 DC	400 AC	500 AC	690 AC	250 DC	440 DC		
Rated operational current*	I _e	A	160	160	160	160	160	250	250	250	250	250		
Conv. free air thermal current with fuse-links*	I _{th}	A	160						250					
Conv. free air thermal current with solid-links*	I _{th}	A	210						325					
Rated frequency	f	Hz	40-60	40-60	40-60	/	/	40-60	40-60	40-60	/	/		
Rated insulation voltage	U _i	V	1000 AC						1000 AC					
Total power loss (without fuse)	P _v	W	1P - 3W, 3P - 9W						1P - 5W, 3P - 15W					
Power loss at 80% I _{th} (without fuse-links), **	P _v	W	1P - 1,9 W, 3P - 5,8 W						1P - 3,2 W, 3P - 9,6 W					
Rated impulse withstand voltage	U _{imp}	kV	8						8					
Utilisation category***			AC-23B	AC-22B	AC-21B	DC-22B	DC-21B	AC-23B	AC-22B	AC-21B	DC-22B	DC-21B		
Rated conditional short-circuit current, ***, ****		kA	120 (500V), 100 (690V)						120 (500V), 100 (690V)					
Rated short-time withstand current	I _{cw}	kA	5/1s						8,6/1s					
Fuse links														
Size - DIN VDE 0636-2	-	-	000/00						1					
Max. rated current (gG)	I _n	A	160	160	160	160	160	250	250	250	250	250		
Max. permissible power loss per fuse link	P _a	W	12						23					
Cable terminal														
Flat terminal-Screw			M8						M10					
Tightening torque	Ma	Nm	12-15						30-35					
Clip terminal, Clamping cross-section		mm ²	Round conductor: 1,5-70 Cu , Laminated copper bar: 6 x 9 x 0,8 Cu						Round conductor: 2,5-150 Cu , Laminated copper bar: 6 x 16 x 0,8 Cu					
Tightening torque	Ma	Nm	2,6						9,5					
Prism Clamp, Clamping cross-section		mm ²	(SP KVL00 P1); 10-70 Al/Cu , 35-95 Al/Cu						(SP KVL1 P1); 10-150 Al/Cu					
Tightening torque	Ma	Nm	(SP KVL00 P1); 2,6						(SP KVL1 P1); 4,5					
Prism Clamp, Clamping cross-section		mm ²							(SP KVL1 P2); 2 x (10-150) Al/Cu					
Tightening torque	Ma	Nm							(SP KVL1 P2); 4,5					
Frame clamp, Clamping cross-section		mm ²	1,5-95 Al/Cu , (Al 95: max. 125A), *****						35-150 Al/Cu					
Torque	Ma	Nm	4,5						12					
Degree of Protection, front side device														
Front cover close	-	-	IP20						IP20					
Front cover open	-	-	IP10						IP10					
With clamp- and lateral cover	-	-	IP2XC						IP2XC					
Operating condition														
Ambient temperature *****	T _{amb}	°C	-25 ... +55						-25 ... +55					
Operating condition	-	-							Continuous operation					
Mounting position	-	-							vertical, horizontal					
Altitude	-	m							≤ 2000					
Pollution degree	-	-							3					
Overvoltage category	-	-	III						III					

* Mounting of several units in low voltage switchgear-combinations, please think about rated diversity factors acc. to DIN EN 61439.

** Reference value for replacement of devices acc. to DIN EN 61439-1 clause 10.10.4.2.

*** minimum distance to earthed, conductive parts: Lateral: 20mm/Above: 50mm

*** a) Lateral: 50mm/Above: 100mm

**** Type tested with NH fuse-links characteristic gG

***** 35°C Normal temperature, at 55°C with reduced operating current

Technical data (in accordance with IEC/EN 60947-3)

Size	2						3					
Technical Characteristics												
Rated operational voltage	U_e	V	400 AC	500 AC	690 AC	250 DC	440 DC	400 AC	500 AC	690 AC	250 DC	440 DC
Rated operational current*	I_e	A	400	400	400	400	400	630	630	630	630	630
Conv. free air thermal current with fuse-links*	I_{th}	A	400					630				
Conv. free air thermal current with solid-links*	I_{th}	A	520					910				
Rated frequency	f	Hz	40-60	40-60	40-60	/	/	40-60	40-60	40-60	/	/
Rated insulation voltage	U_i	V	1000 AC					1000 AC				
Total power loss (without fuse)	P_v	W	1P - 9W, 3P - 28W					1P - 17W, 3P - 51W				
Power loss at 80% I _{th} (without fuse-links), **	P_v	W	1P - 6 W, 3P - 17,9 W					1P - 10,9 W, 3P - 32,6 W				
Rated impulse withstand voltage	U_{imp}	kV	8					8				
Utilisation category***			AC-23B	AC-22B	AC-21B	DC-22B	DC-21B	AC-23B	AC-22B	AC-21B	DC-22B	DC-21B
Rated conditional short-circuit current, ***, ****		kA	120 (500V), 100 (690V)					120 (500V), 100 (690V)				
Rated short-time withstand current	I_{cw}	kA	15/1s					15/1s				
Fuse links												
Size - DIN VDE 0636-2	-	-	2					3				
Max. rated current (gG)	I_n	A	400	400	400	400	400	630	630	630	630	630
Max. permissible power loss per fuse link	P_a	W	34					48				
Cable terminal												
Flat terminal-Screw			M10					M10 / M12				
Tightening torque	M_a	Nm	30-35					30-35				
Clip terminal, Clamping cross-section		mm ²	Round conductor: 25-150 Cu, Laminated copper bar: 10 x 16 x 0,8 Cu					Laminated copper bar: 11 x 21 x 1 Cu				
Tightening torque	M_a	Nm	23					23				
Prism Clamp, Clamping cross-section		mm ²	(SP KVL2 P1); 120-240 Al/Cu					(SP KVL3 P1); 120-300 Al/Cu				
Tightening torque	M_a	Nm	(SP KVL2 P1); 11					(SP KVL3 P1); 11				
Prism Clamp, Clamping cross-section		mm ²	(SP KVL2 P2); 2 x (120-150) Al/Cu					(SP KVL3 P2); 2 x (120-240) Al/Cu				
Tightening torque	M_a	Nm	(SP KVL2 P2); 11					(SP KVL3 P2); 11				
Frame clamp, Clamping cross-section		mm ²	95-300 Al/Cu					95-300 Al/Cu				
Torque	M_a	Nm	20					20				
Degree of Protection, front side device												
Front cover close	-	-	IP20					IP20				
Front cover open	-	-	IP10					IP10				
With clamp- and lateral cover	-	-	IP2XC					IP2XC				
Operating condition												
Ambient temperature *****	T_{amb}	°C	-25 ... +55					-25 ... +55				
Operating condition	-	-	Continuous operation					Continuous operation				
Mounting position	-	-	vertical, horizontal					vertical, horizontal				
Altitude	-	m	≤ 2000					≤ 2000				
Pollution degree	-	-	3					3				
Overvoltage category	-	-	III					III				

* Mounting of several units in low voltage switchgear-combinations, please think about rated diversity factors acc. to DIN EN 61439.

** Reference value for replacement of devices acc. to DIN EN 61439-1 clause 10.10.4.2.

*** minimum distance to earthed, conductive parts: Lateral: 20mm/Above: 50mm

*** a) Lateral: 50mm/Above: 100mm

**** Type tested with NH fuse-links characteristic gG

***** 35°C Normal temperature, at 55°C with reduced operating current

Technical data

Technical data (in accordance with IEC/EN 60947-3)								
Size	4a			4a				
Technical Characteristics								
Rated operational voltage	U_e	V	500 AC	690 AC	220 DC	500 AC	690 AC	220 DC
Rated operational current	I_e	A	1250			1600		
Conv. free air thermal current with fuse-links	I_{th}	A	1250			1600		
Conv. free air thermal current with solid-links	I_{th}	A	1250			1600		
Rated frequency	f	Hz	40-60	40-60	/	40-60	40-60	/
Rated insulation voltage	U_i	V	800			800		
Total power loss (without fuse)	P_v	W	32			52		
Rated impulse withstand voltage	U_{imp}	kV	8			8		
Utilisation category			AC-23B	AC-21B	DC-21B	AC-22B	AC-21B	DC-21B
Rated conditional short-circuit current		kA	80 (500V), 50 (690V)					
Rated short-time withstand current	I_{cw}	kA	35					
Fuse links								
Size - DIN VDE 0636-2	-	-	4a					
Max. rated current (gG)	I_n	A	1250			1600		
Max. permissible power loss per fuse link	P_a	W	110			164		
Cable terminal								
Flat terminal-Screw			M16			2x M12		
Tightening torque	M_a	Nm	50-60			35-40		
Cable lug		mm ²						
Flat bar		mm						
Degree of Protection front side device								
Front cover close	-	-	IP20			IP20		
Front cover open	-	-	IP10			IP10		
Operating condition								
Ambient temperature *	T_{amb}	°C	-25 ... +55			-25 ... +55		
Operating condition	-	-	Continuous operation					
Mounting position	-	-	vertical, horizontal					
Altitude	-	m	≤ 2000					
Pollution degree	-	-	3					
Overvoltage category	-	-	III			III		

* 35°C Normal temperature, at 55°C with reduced operating current

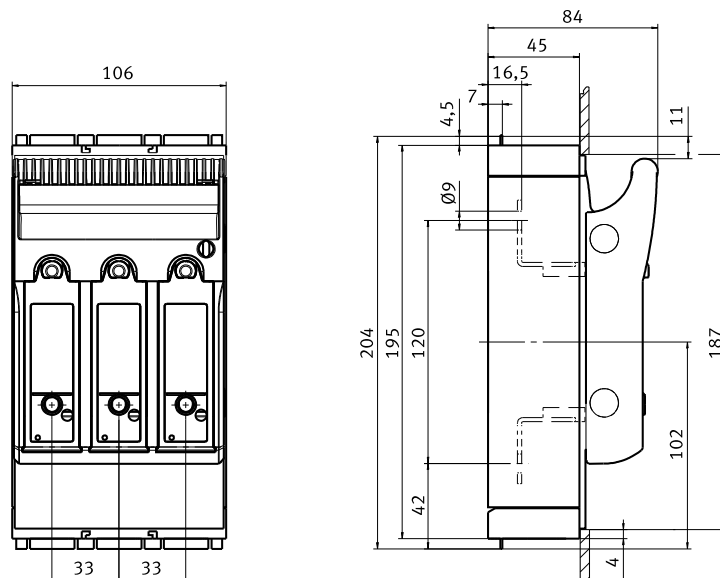

KVL-00 3p M8-M8
KVL-00 3p BC95-BC95
KVL-00 3p M8-M8 LED
KVL-00 3p BC95-BC95 LED

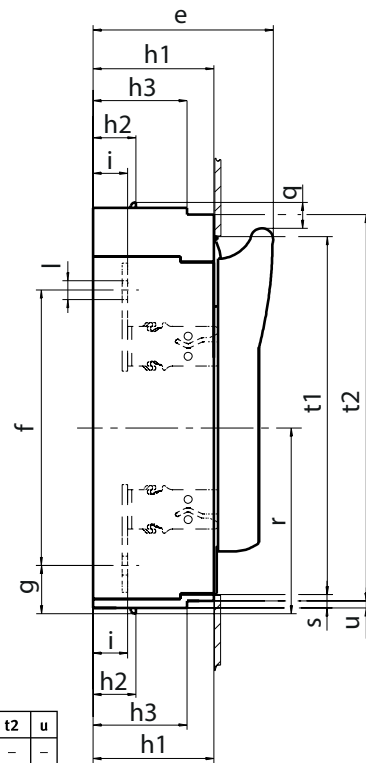
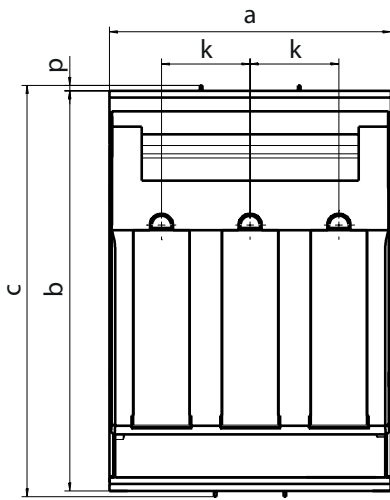

	a	b	c	e	f	g	h1	h2	h3	i	k	l	p	q	r	s	t1	t2	u
KVL-1 3p M10-M10 (LED)	184	298	306	117	185	46	70	32	-	25	58	∅10,5	4	19	138	5	272	-	-
KVL-2 3p M10-M10 (LED)	210	298	306	134	205	36	90	32	70	26	66	∅14	4	19	138	10	268	288	5
KVL-3 3p M10-M10 (LED)	250	298	306	143	205	36	90	32	70	26	82	∅14	4	19	138	10	268	288	5

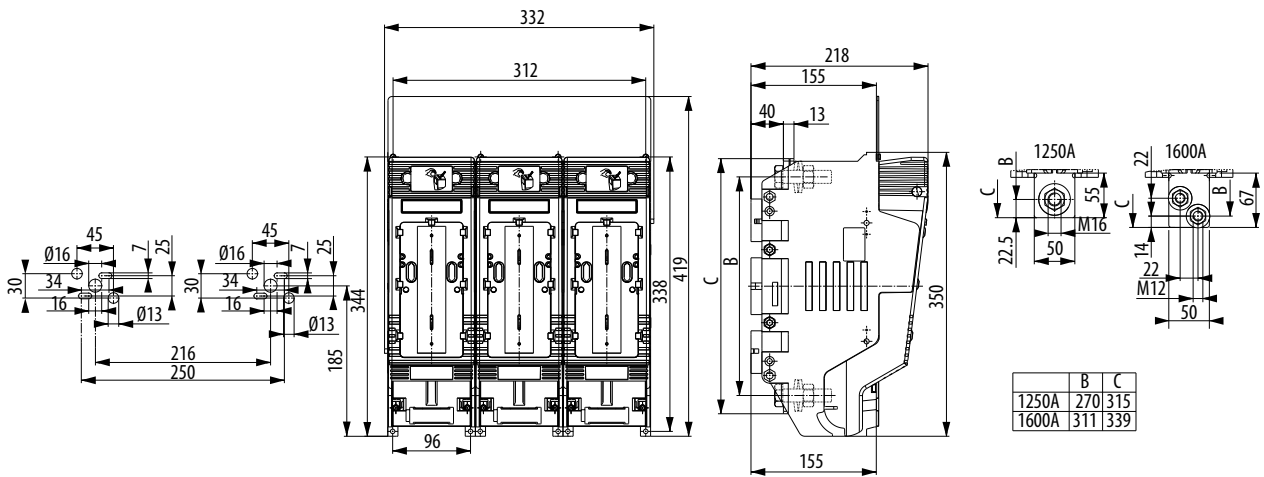

HVL 4a 3p

	B	C
1250A	270	315
1600A	311	339

Technical data

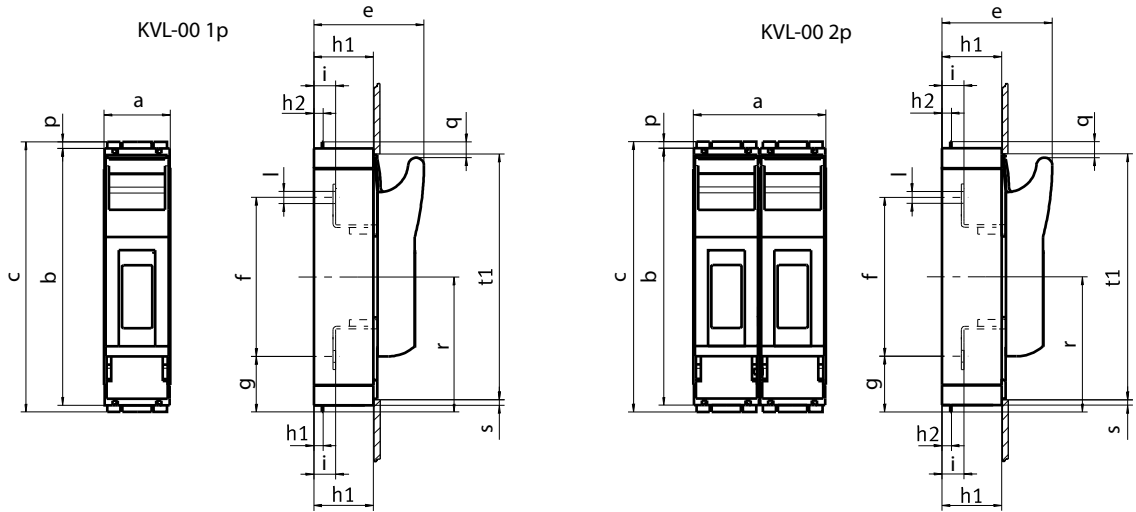

	a	b	c	e	f	g	h1	h2	h3	i	l	p	q	r	s	t1
KVL-00 1p M8-M8	50	195	204	84	120	42	45	7	-	16,5	Ø9	4,5	12	102	5	187
KVL-00 2p M8-M8	100	195	204	84	120	42	45	7	-	16,5	Ø9	4,5	12	102	5	187

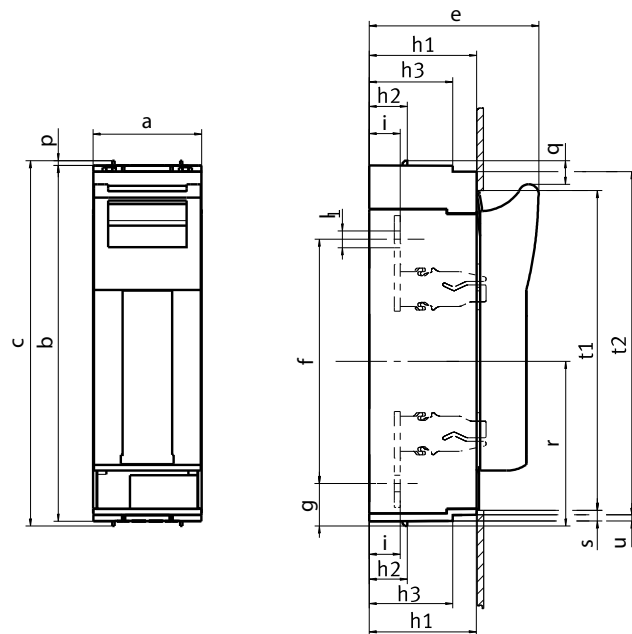

	a	b	c	e	f	g	h1	h2	h3	i	l	p	q	r	s	t1	t2	u
KVL-1 1p M10-M10	69	298	306	117	185	46	70	32	-	25	Ø10,5	4	19	138	5	272	-	-
KVL-3 1p M10-M10	91	298	306	143	205	36	90	32	70	26	Ø14	4	19	138	10	268	288	5

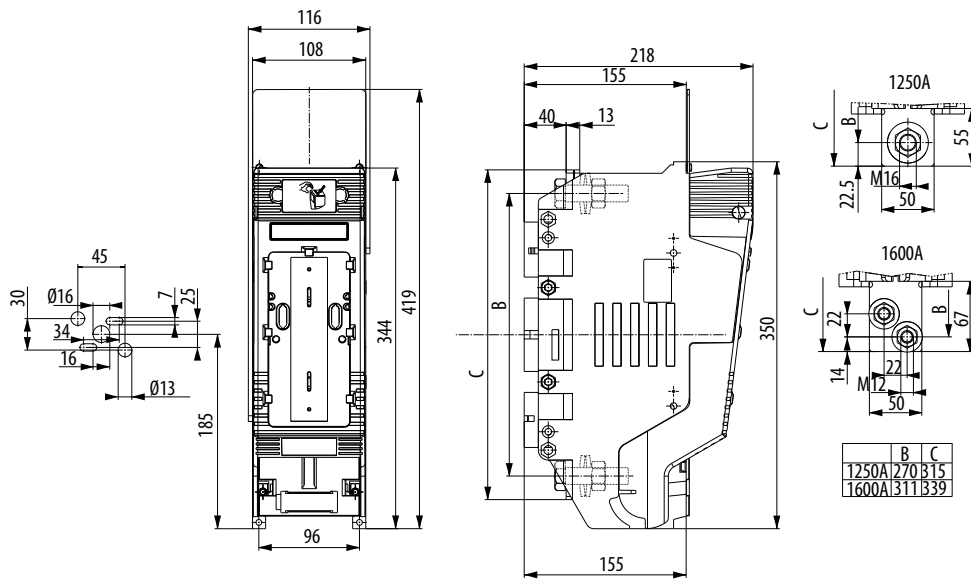

HVL 4a 1p

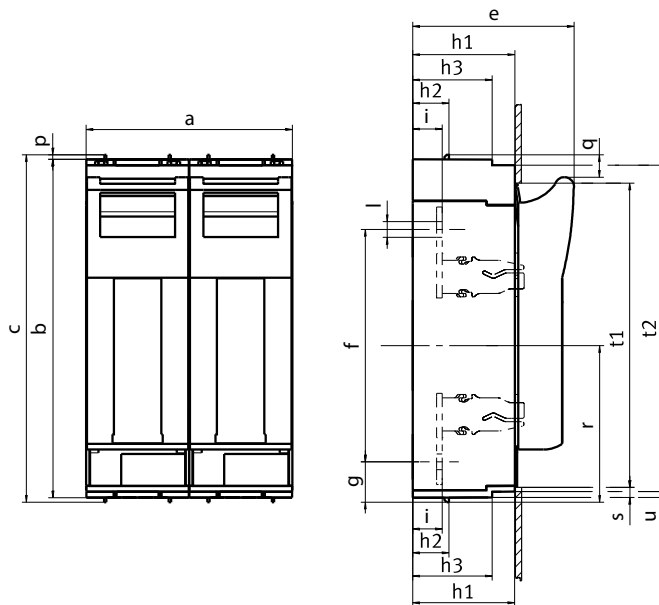

	a	b	c	e	f	g	h1	h2	h3	i	l	p	q	r	s	t1	t2	u
KVL-1 2p M10-M10	138	298	306	117	185	46	70	32	-	25	Ø10,5	4	19	138	5	272	-	-
KVL-3 2p M10-M10	182	298	306	143	205	36	90	32	70	26	Ø14	4	19	138	10	268	288	5

Technical data

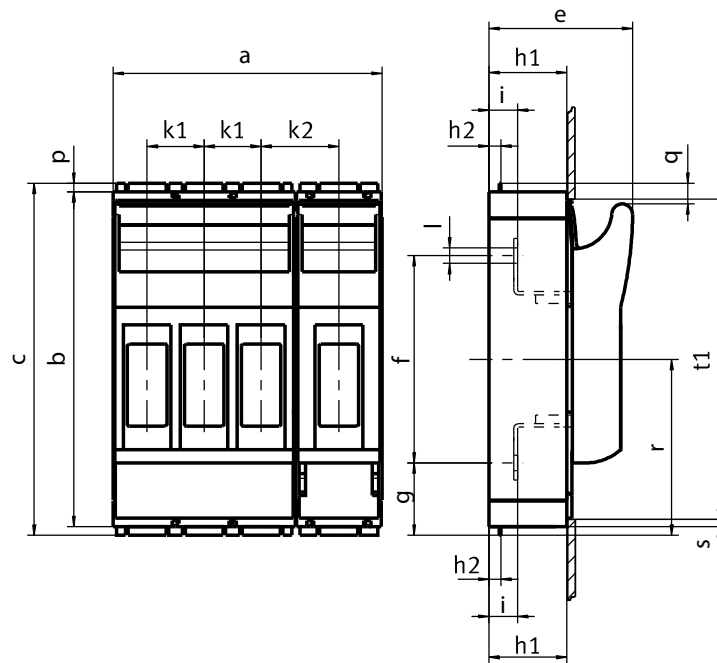

	a	b	c	e	f	g	h1	h2	h3	k1	k2	i	l	p	q	r	s	t1	t2	u
KVL-00 4p M8-M8	156	195	204	84	120	42	45	7	-	33	45	16,5	Ø9	4,5	12	102	5	187	-	-

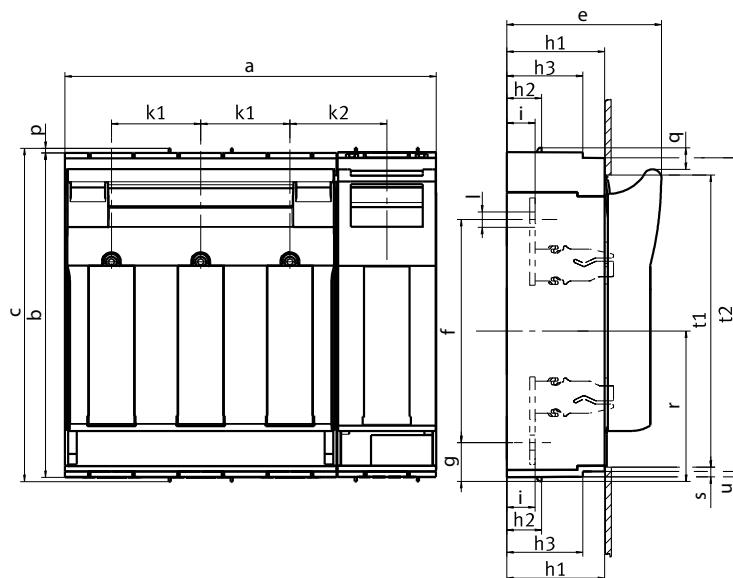

	a	b	c	e	f	g	h1	h2	h3	k1	k2	i	l	p	q	r	s	t1	t2	u
KVL-1 4p	254	298	306	117	185	46	70	32	-	58	69	25	Ø10,5	4	19	138	5	272	-	-
KVL-3 4p	341,5	298	306	143	205	36	90	32	70	82	89	26	Ø14	4	19	138	10	268	288	5

Technical data - Feeding clamps

Technical Characteristics

Max. electrical load			AC690V/DC1000V-250A
Heat deflection temp.			125°C UL94: V0
Comparative tracking index			600

Cross sections

Conductor - Max. Diameter Ø14 mm			
single wire		mm ²	25 - 95
multi wire		mm ²	25 - 95
fine wire (with end sleeve)		mm ²	25 - 70
Torque	Ma	Nm	13
Degree of protection			IP20
Regulations			EN 60998-1:2004; EN 60998-2:2004; EN 60999-1:2000; EN 60999-2:2003



Important

This Terminal is suitable for Al and Cu conductors. Please pay attention to the common handling guidelines when connecting the Aluminium conductors. Clean and brush the contact surfaces and lubricate them with an appropriate grease.

Technical data - Phase busbars

Technical Characteristics

Rated cross section of the conductor		mm ²	50
Impulse voltage strenght		kV	≥8,5
Min. air distance		mm	>8
Min. creeping distance		mm	>9
Max. operating voltage		V	AC690
Protection class			IP20
Short circuit rating			IPK=25kA/0,1s, Surge energy capacity IPK, ICC 100kA - NH3 355A gL 500V
Dielectric strenght		kV/mm	≥32
Capacity at 35°C ambient temperature depending of feeding point cross section			
Busbar lenght		mm	max. 300
Feeding at beginning/ending			
Max. current Is /Phase		A	250
Connection cross current		mm ²	95
Other feedings			
Max. feeding current Ie /Phase		A	250
Connection cross current		mm ²	95
Overvoltage category / degree of pollution			III / 2
Regulations			IEC 60947-1:2007

Technical data

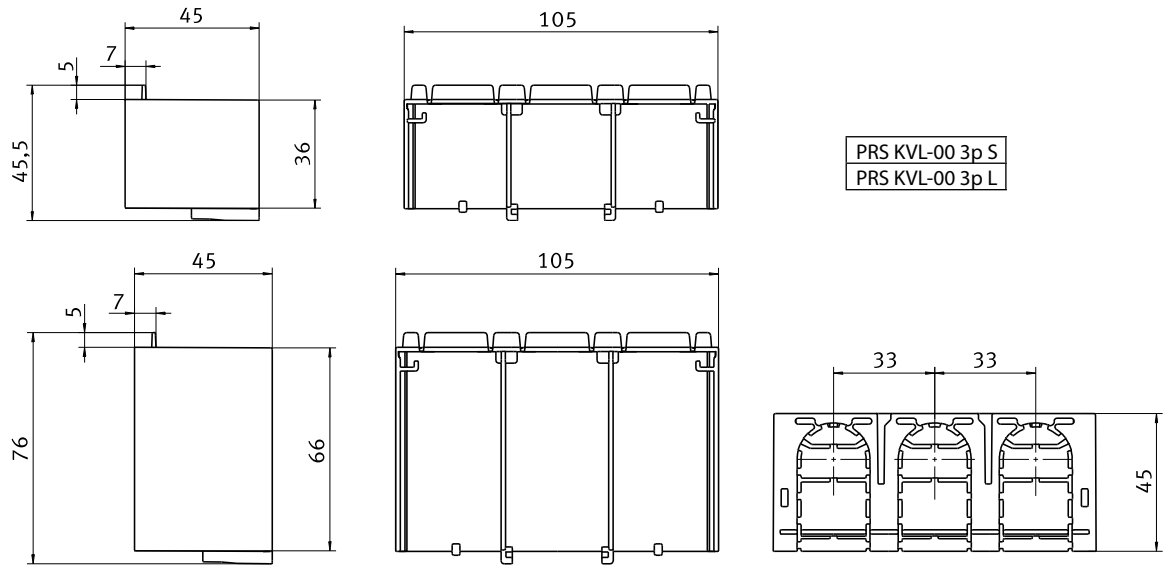

PRS KVL-00 3p S
PRS KVL-00 3p L

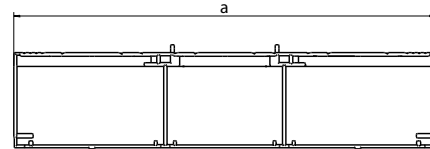
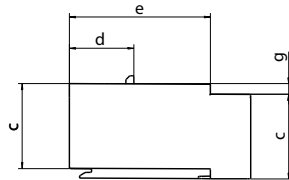

	a	b	c	d	e	f	g
PRS KVL-1 3p	184	70	42	32	-	58	-
PRS KVL-2 3p	210	90	42	32	70	66	5
PRS KVL-3 3p	250	90	42	32	70	82	5

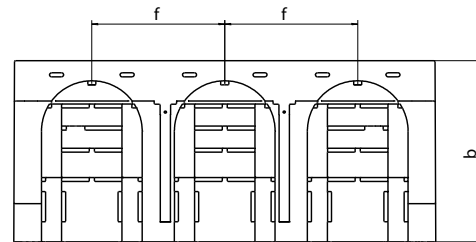

PRS KVL-00 1p L

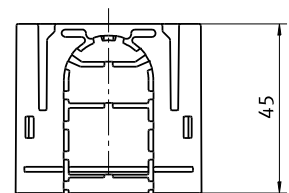
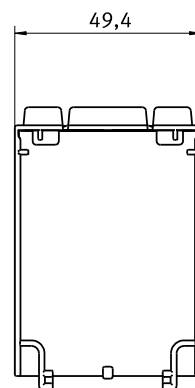
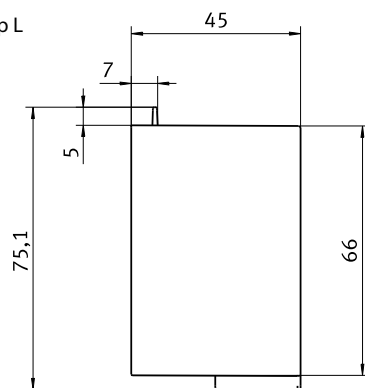

PRS KVL-00 1p S

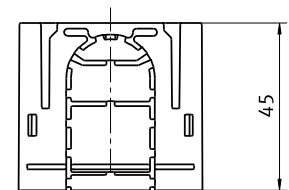
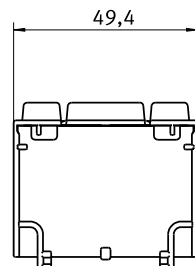
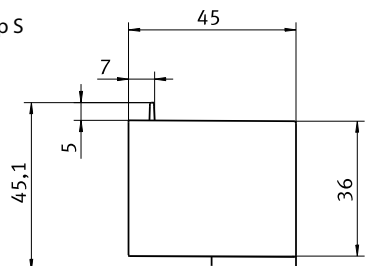

PRS KVL-1 1p

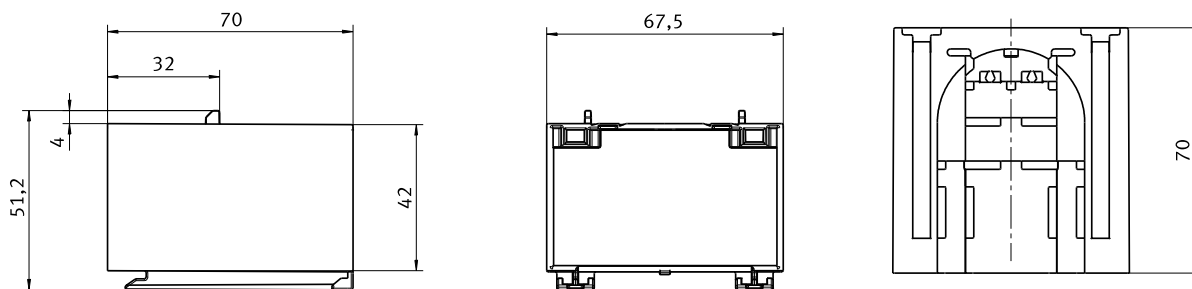

PRS KVL-3 1p

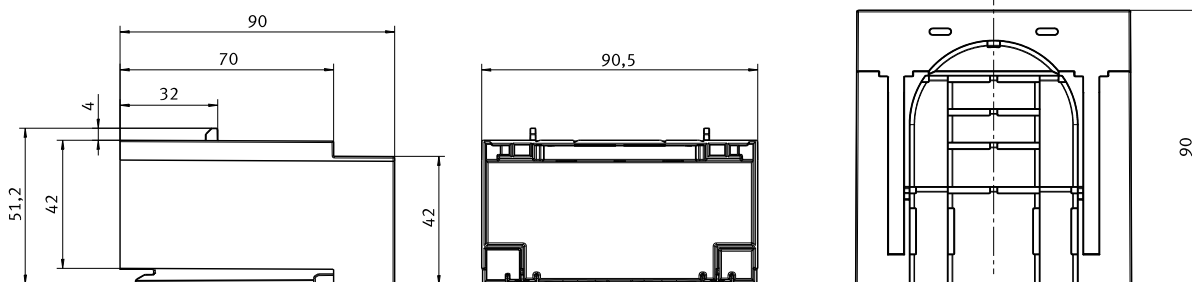

Technical data - Electronic fuse monitoring unit EFMU KVL			
Technical Characteristics			
Rated operational voltage	U_e	V	AC400-500 (+/-10%)
Power supply			Self-powered
Input power		VA	1,5
Overvoltage category			230/400 V : III , (4kV) 500 V : II , (4kV)
Rated frequency	f	Hz	50-60
Input resistance			>1k Ohm/V
Output channels			
Relay output			1NC/1NO
Maximum voltage		V	AC250/DC24
Maximum switching current		A	1
General data			
Operation indicator			1 LED green
Alarm indicator			3 LED (F1, F2, F3) red
Functional test			Test key for relay + LEDs
EMC			IEC 61000-4-5/IEC 61000-4-4
Degree of protection			IP 3X
Operating conditions			
Ambient temperature	T_{amb}	°C	-5 ... +55

No single detection of parallel connected fuses!

Technical data

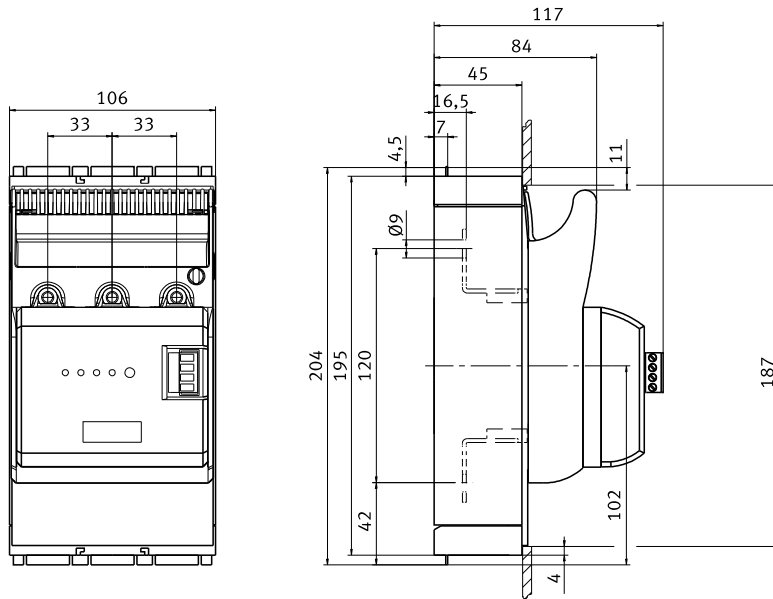

KVL-00 3p M8-M8 + EFMU KVL-00 3p
 KVL-00 3p BC95-BC95 + EFMU KVL-00 3p

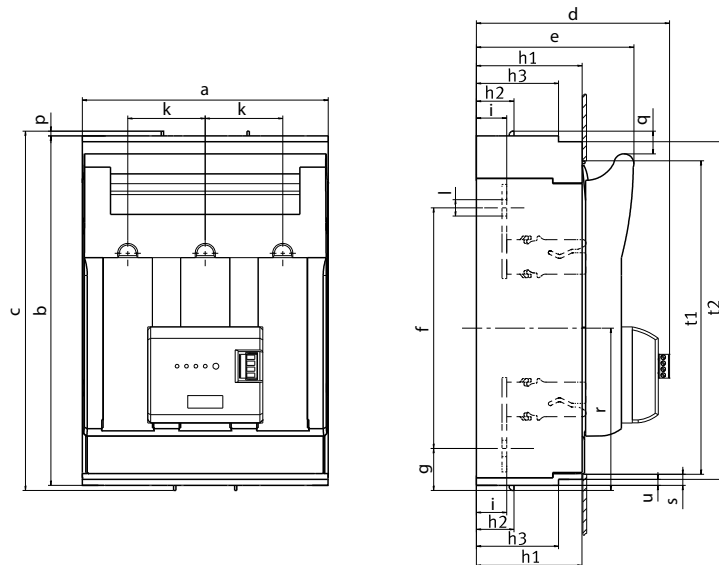

	a	b	c	d	e	f	g	h1	h2	h3	i	k	l	p	q	r	s	t1	t2	u
KVL-1 3p M10-M10 + EFMU KVL-1 3p	184	298	306	148	117	185	46	70	32	-	25	58	Ø10,5	4	19	138	5	272	-	-
KVL-2 3p M10-M10 + EFMU KVL-2 3p	210	298	306	165	134	205	36	90	32	70	26	66	Ø14	4	19	138	10	268	288	5
KVL-3 3p M10-M10 + EFMU KVL-3 3p	250	298	306	173	143	205	36	90	32	70	26	82	Ø14	4	19	138	10	268	288	5

Technical data - Electromechanical fuse monitoring unit MPFMU KVL

Technical Characteristics

Rated operational voltage	U_e	V	AC24...690 DC24...250
Rated short-circuit breaking capacity	I_{cn}	kA	100
Overvoltage category			230/400V : III (4kV) 500V : II (4kV)
Output channels			
Relay output			1NC/1NO
Maximum voltage		V	AC230/DC24
Maximum switching current			2,5A...AC-12 / 1A...DC-13

No single detection of parallel connected fuses!

Safety notes

May not be used for safety monitoring in feeders with power control units where, in the event of a fault, it is possible for a DC feedback of >300V (or >600V where 3 current paths are connected in parallel) to occur. If equipment has to be disconnected on the load side of the fuses to be monitored, make sure that no parasitic voltages can arise in the circuit-breaker that is connected in parallel with the fuse-monitoring device.

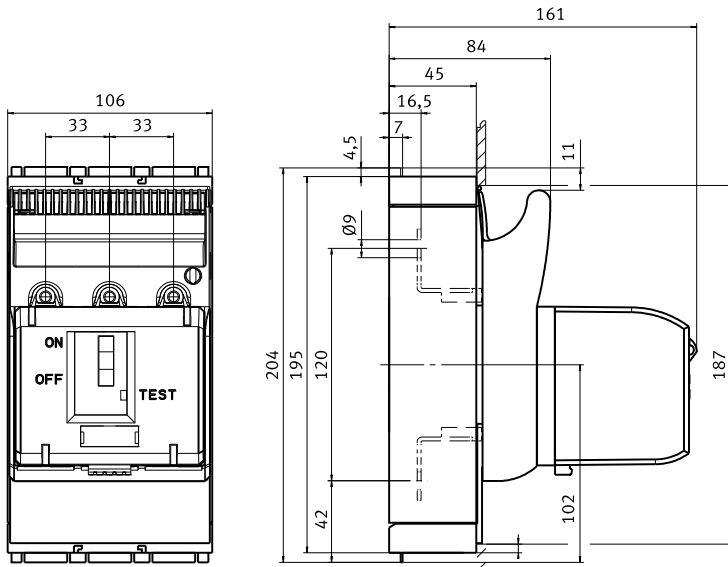

KVL-00 3p M8-M8 + MPFMU KVL-00 3p
 KVL-00 3p BC95-BC95 + MPFMU KVL-00 3p

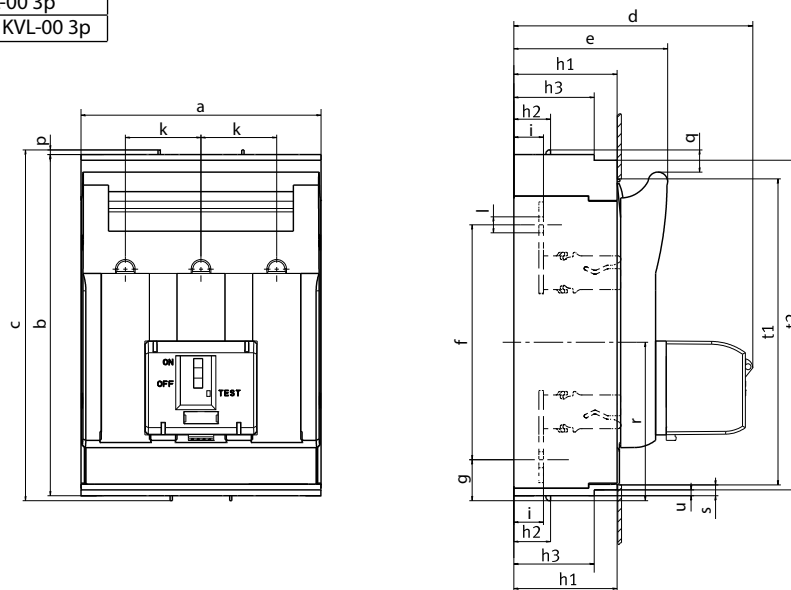

	a	b	c	d	e	f	g	h1	h2	h3	i	k	l	p	q	r	s	t1	t2	u
KVL-1 3p M10-M10 + MPFMU KVL-1 3p	184	298	306	192	117	185	46	70	32	-	25	58	Ø10,5	4	19	138	5	272	-	-
KVL-2 3p M10-M10 + MPFMU KVL-2 3p	210	298	306	209	134	205	36	90	32	70	26	66	Ø14	4	19	138	10	268	288	5
KVL-3 3p M10-M10 + MPFMU KVL-3 3p	250	298	306	217	143	205	36	90	32	70	26	82	Ø14	4	19	138	10	268	288	5

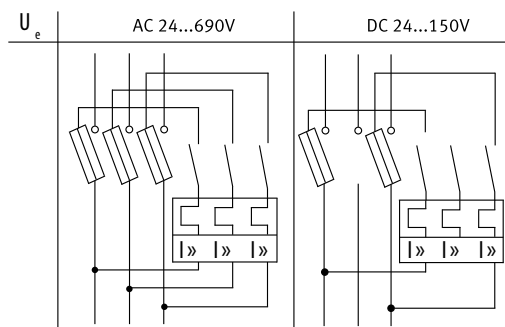

Technical data

Horizontal fuse-switch disconnecter type HVL EK size 000 and 00

Technical data			HVL EK 000 1p		HVL EK 000 3p		HVL EK 00 1p		HVL EK 00 3p	
Conventional free air thermal current*	I_{th}	A	160							
Rated insulation voltage	U_i	V	AC 690							
Rated withstand voltage	U_{imp}	kV	6							
Rated frequency		Hz	50 (40-60)							
Utilisation category			AC-21B	AC-22B	AC-21B	AC-22B	AC-21B	AC-22B	AC-21B	AC-22B
Rated operational current	I_e	A	160	125	160	100	160	125	160	125
Rated operational voltage	U_e	V	230 AC	690 AC	400 AC	500 AC	230 AC	690 AC	400 AC	500 AC
Rated conditional short-circuit current		kA_{eff}	63							
Mechanical durability (operating cycles)			1600							
Electrical durability (operating cycles)			200							
Power dissipation (without fuse)		W	3,74		10,2		3,74		10,2	
Degree of protection (cover closed)			IP20							
Degree of protection (cover open)			IP10							
Pollution degree			3							
Permissible ambient temperature**		°C	-25 ÷ +55							
Storage temperature		°C	-30 ÷ +70							

* In case of mounting of the fuse-switch disconnecter in cabinet, the thermal current should be corrected (I_{th} x derating factor), depending on the number of built apparatuses (see table 1)

** In case of using the fuse-switch disconnecter at temperatures +45°C to +55°C, the thermal current I_{th} should be reduced for 5%-10%

Number of built apparatuses	2 - 3	4 - 5	6 - 9	>9
Derating factor	0,9	0,8	0,7	0,6

HVL EK 000 1p

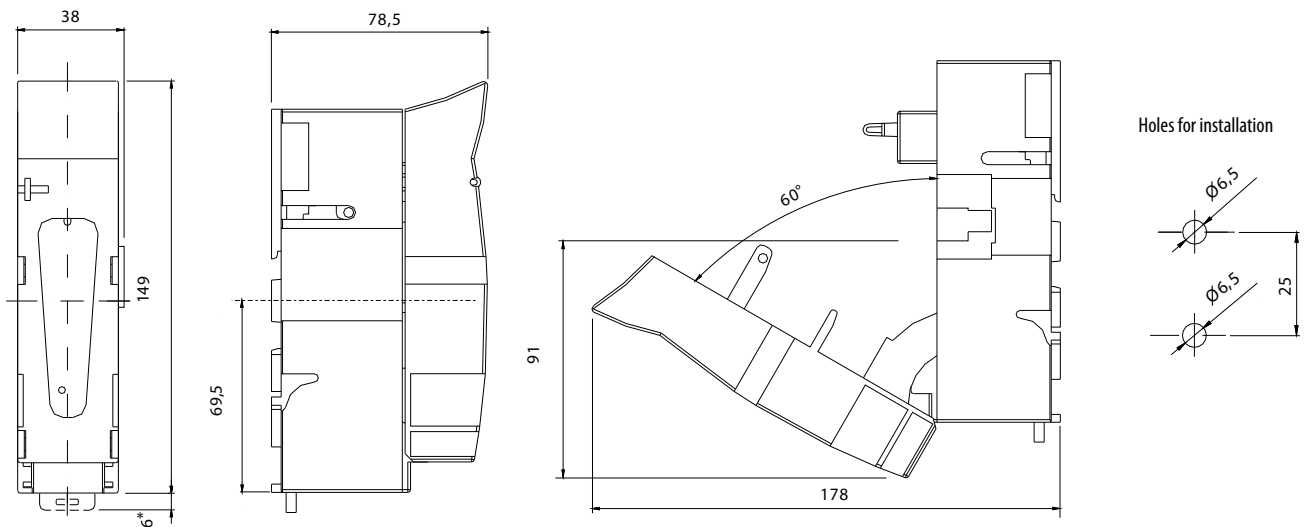

HVL EK 000 3p

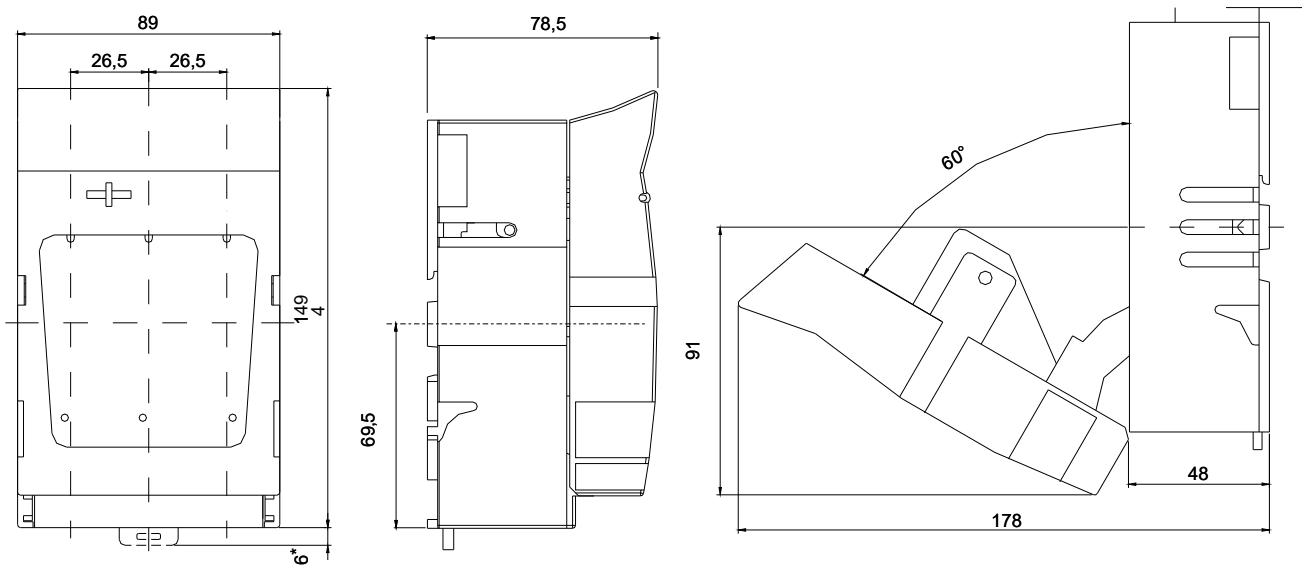

Holes for installation

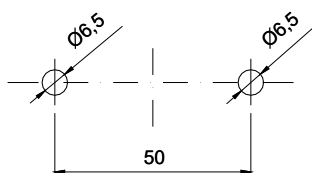

HVL EK 000 4p

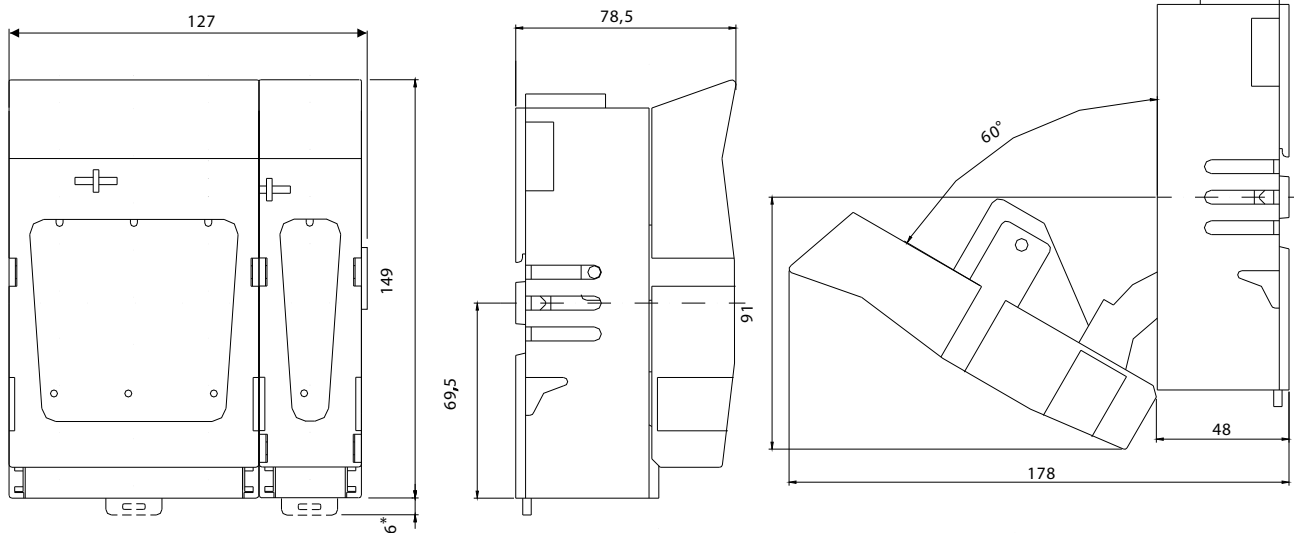

Holes for installation

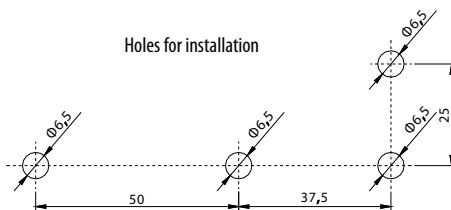

Technical data

HVL EK 000 – options and Installation guide

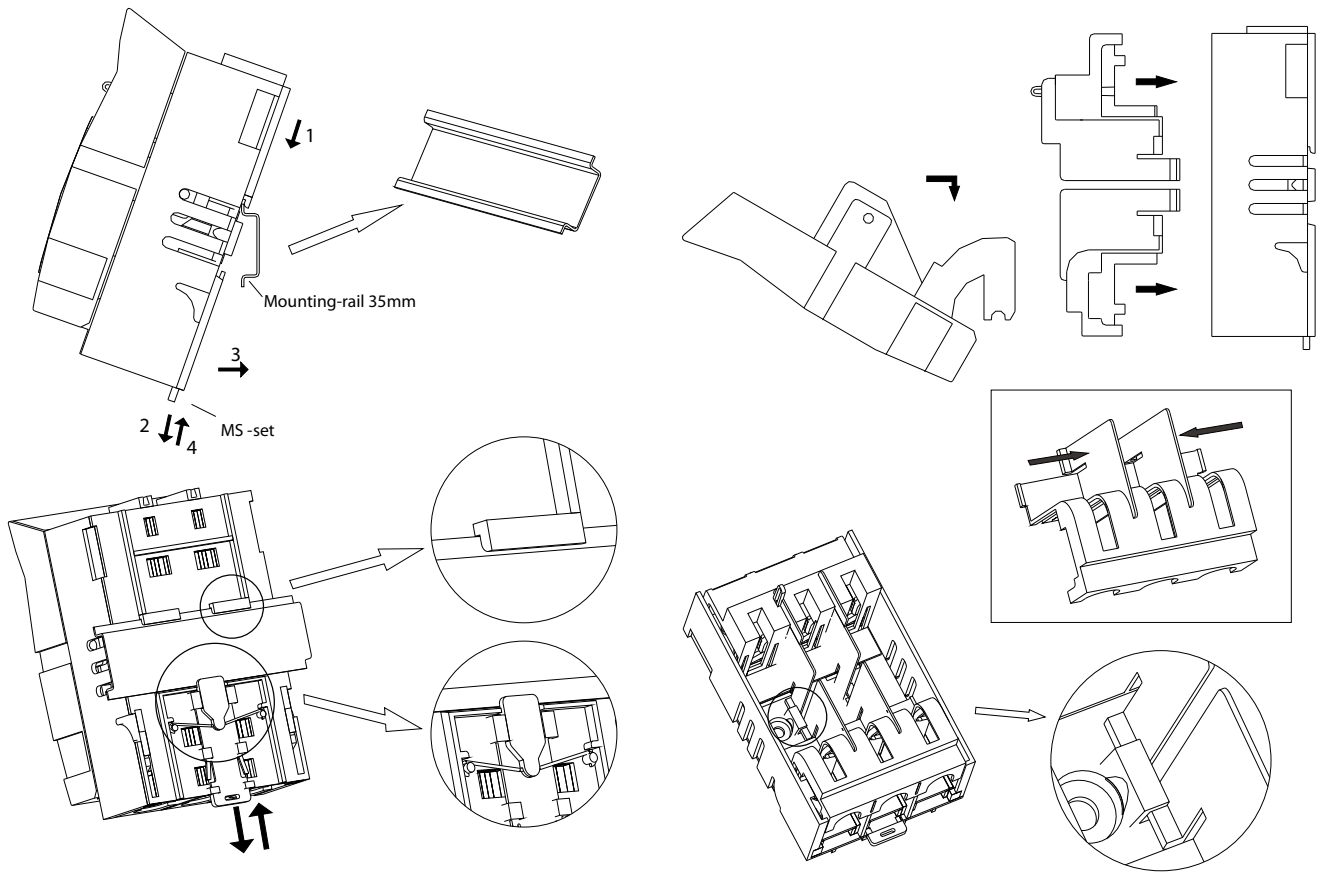

HVL-B EK 000 3p

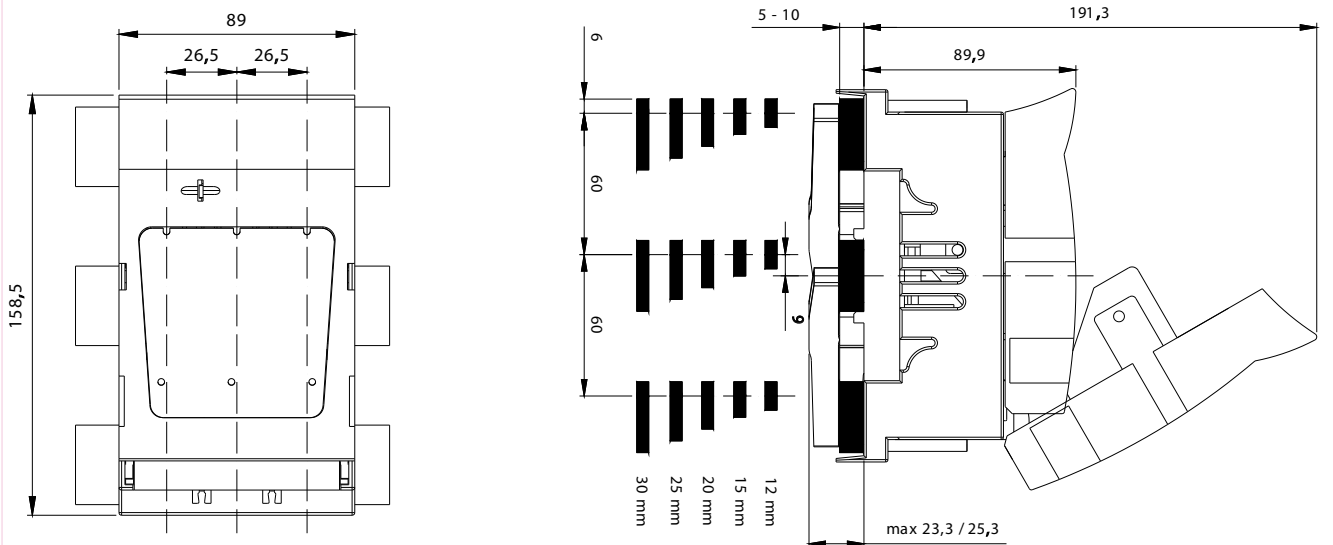

HVL-P EK 000 3P

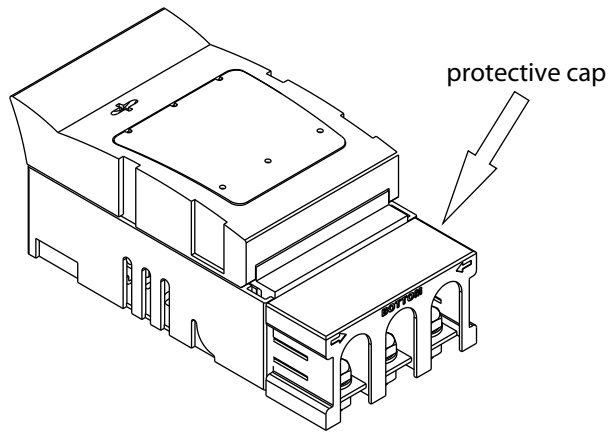
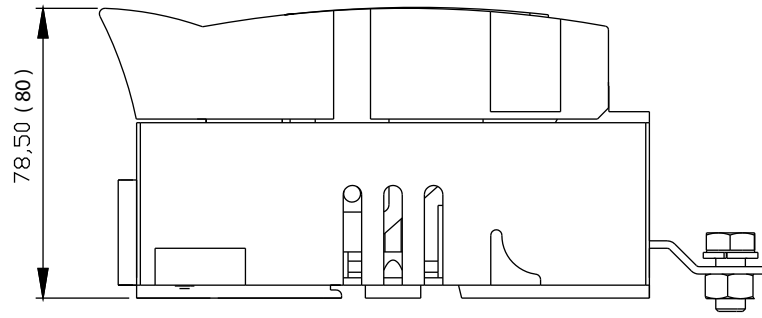
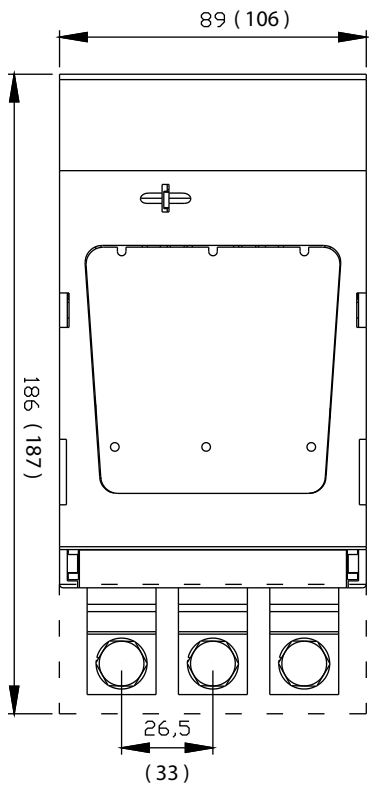

Holes for installation

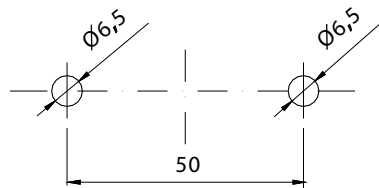

HVL-P EK 000 3p is supplied complete with a bottom covering protection. HVL-P EK 00 3p is supplied without protective coatings.

HVL EK 00 1p

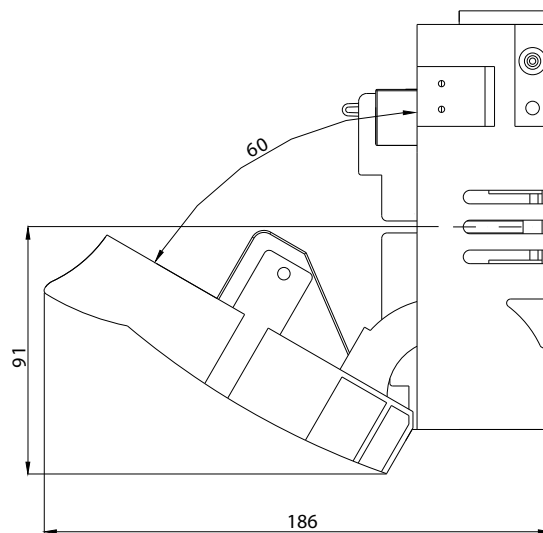
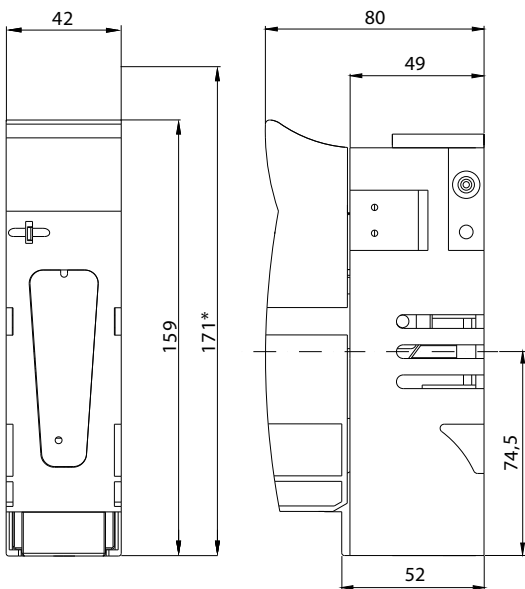

Holes for installation

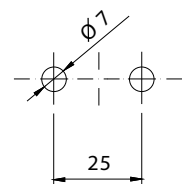

Technical data

HVL EK 00 3p

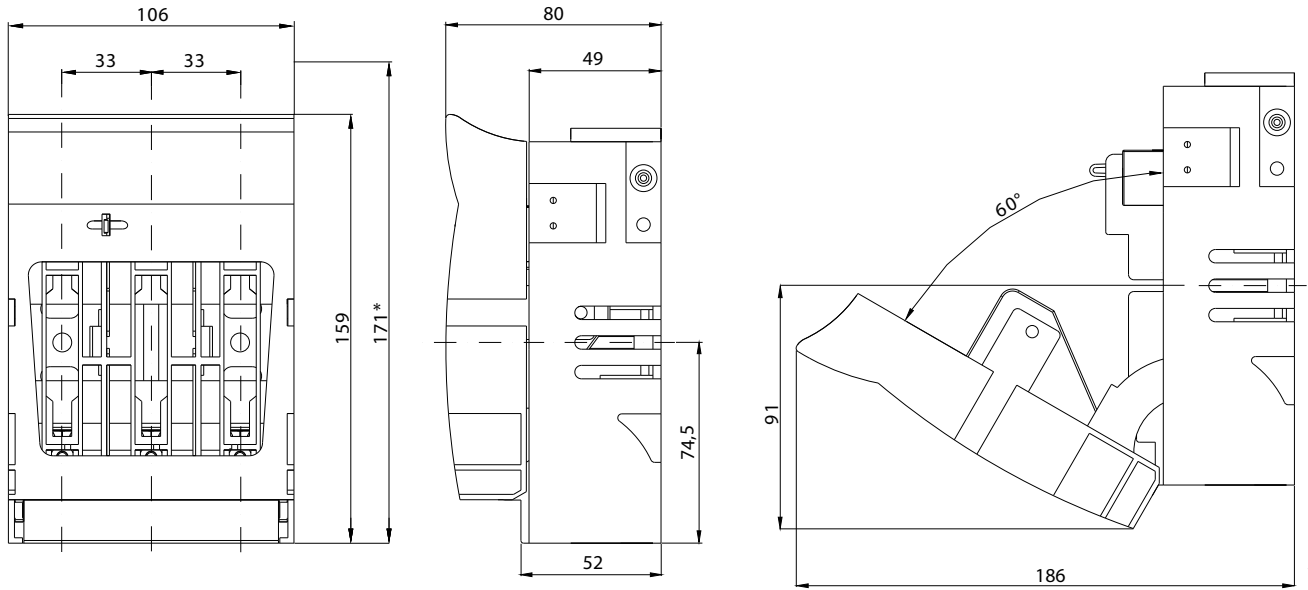

Holes for installation

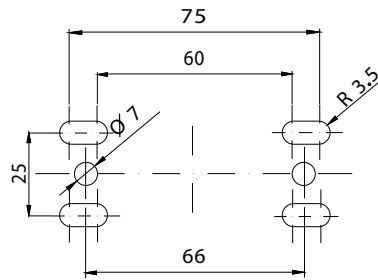

HVL EK 00 4p

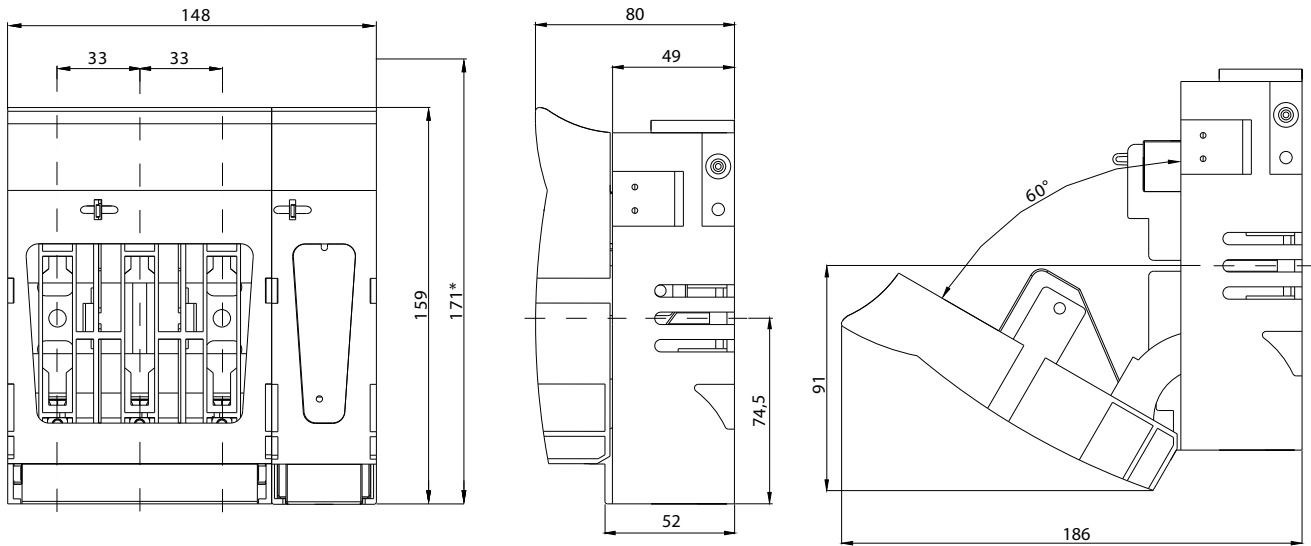

Holes for installation

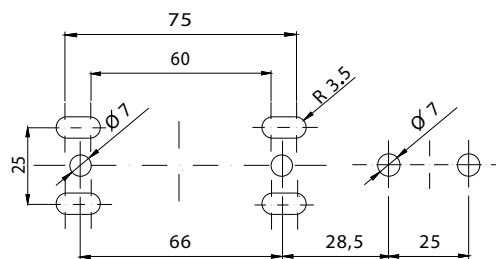

* with set for mounting on two mounting rails in distance (125mm, 150mm)

